

Products compatible with the environments of the secondary battery manufacturing process are available, contributing to the improvement of productivity and reduced defects.

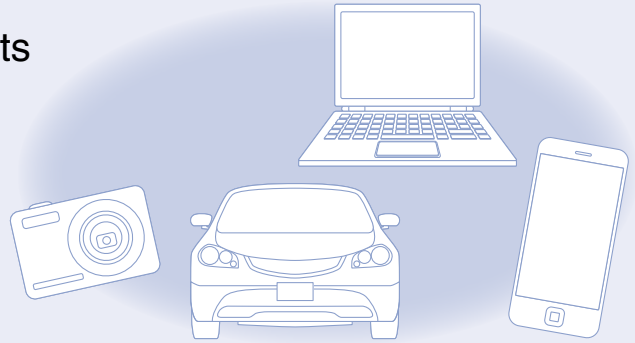

Series Compatible with Secondary Batteries 25A- Series



Improved performance in environments with low dew points

- Uses grease compatible with low dew points

Double the durability

Durability comparison (Air cylinder)

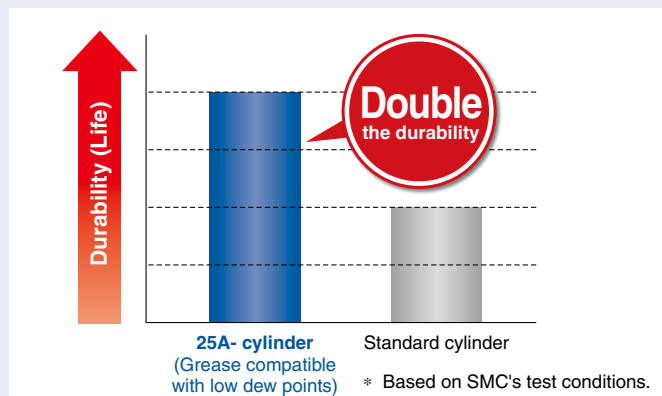

Response time reduced by half

Comparison of cylinder response times after being pressurized and stored

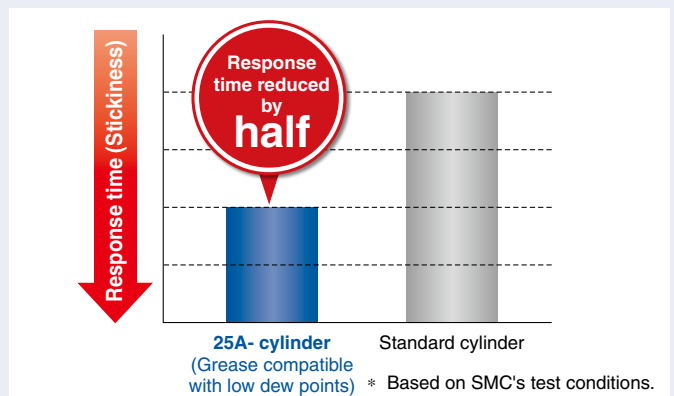

Material Restrictions

The following materials are not used in order to reduce the number of defective products produced during the secondary battery manufacturing process:

- **Metal materials whose main component is either copper or zinc are not used.**
 - * Some of the aluminum alloy and aluminum die-cast materials contain traces of copper or zinc as an additive element. If a product with restrictions on the amounts of these additive elements is required, we can accommodate your needs via a special product. Please contact your local sales representative for further details.
- **Electrolytic nickel plating with a copper layer or zinc plating are not used.**
 - * Electroless nickel plating is used.
- **Parts of the piston rod, clevis pin, split pin, etc., of the cylinder are made of carbon steel with hard chrome plating. Therefore, as the processed parts aren't coated, an anti-rust oil coating is applied to these parts before shipment.**
 - * Rust may be generated due to the operating environment. If the generation of rust is a problem, made-to-order options using stainless steel, etc., are available. Please contact your local sales representative for further details.
- **The coils of solenoid valves, the circuit boards of electrical equipment, the motors of electric actuators, etc., use copper materials.**
 - * Parts whose materials cannot be easily changed to alternative ones and parts whose functions would be compromised by changing to alternative materials use copper and/or zinc materials. Please contact your local sales representative for further details.

Restrictions

Material

Copper (Cu)

Zinc (Zn)

Surface treatment

- Electrolytic nickel plating with a copper layer
 - Zinc plating
- (Electroless nickel plating is used.)

Solenoid Valve 25A-SY Series

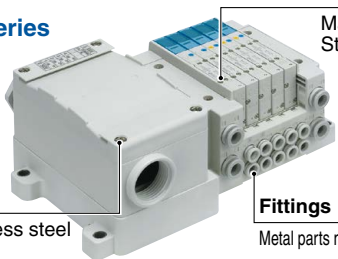

Mounting bolt
Material: Stainless steel

Cover holding screw
Material: Stainless steel

Fittings
Metal parts material: Stainless steel

* Coils for solenoid valves, connector pins, and lead wires are made of copper.
* Manifold terminal block, wiring parts, connector metal parts, and printed circuit board are made of copper.

Cylinder 25A-CA2 Series

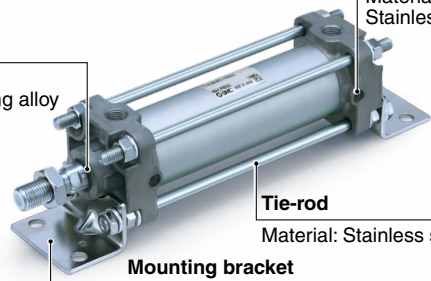

Bushing
Material: Steel bearing alloy

Cushion valve
Material: Stainless steel

Tie-rod
Material: Stainless steel

Mounting bracket
Surface treatment: Electroless nickel plating

Compact Cylinder 25A-CQ2 Series

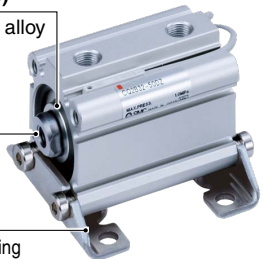

Bushing (ø50 to ø100)
Material: Steel bearing alloy

Piston rod
Surface treatment: Hard chrome plating

Mounting bracket
Surface treatment: Electroless nickel plating

* The auto switch magnet contains copper and/or zinc. (ø12)

Compact Guide Cylinder 25A-MGPM Series



Bushing (ø50 to ø100)
Material: Steel bearing alloy

Piston rod
Surface treatment: Hard chrome plating

Plate
Surface treatment: Electroless nickel plating

* The auto switch magnet contains copper and/or zinc. (ø12)

Air Slide Table 25A-MXQ Series

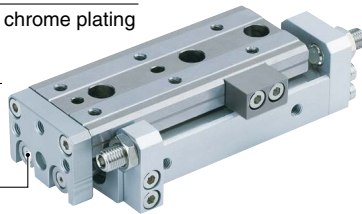

Piston rod
Surface treatment: Hard chrome plating

Piston
Material: Stainless steel
Aluminum alloy

Bolts
Surface treatment: Electroless nickel plating

Corrosion-resistant Air Slide Table (Made to Order: 25A-MXQ□-X771, 25A-MXS□-X1949)

The material of the head cap part has been changed to a highly corrosion-resistant material.



	After change	Before change
Head cap	Aluminum alloy	Synthetic resin

Dual Rod Cylinder/Compact Type 25A-CXSJ Series



Bolts
Surface treatment: Electroless nickel plating

* The auto switch magnet contains copper and/or zinc. (ø6, ø10, ø15)

Air Gripper 25A-MH22 Series

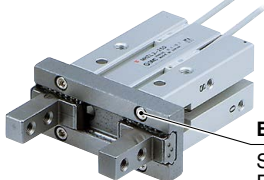

Bolts
Surface treatment: Electroless nickel plating

* Cylinder mounting brackets made of steel are either electroless nickel plated, treated with RAYDENT®, or coated with electrodeposition paint.

Air Filter 25A-AF Series

Rod (AF50 to 60-D)
Material: Stainless steel

Drain plug (AF30 to 60-A, AF30 to 60-D)
Material: Stainless steel



Regulator 25A-AR Series

Valve, Stem
Material: Stainless steel

Adjusting spring, Screw
Surface treatment: Electroless nickel plating



Precision Regulator 25A-IR□-A Series

Screw
Surface treatment: Electroless nickel plating

Screws
Material: Stainless steel



Vacuum Regulator 25A-IRV Series

Stem, Valve, Screws
Material: Stainless steel

Seal, O-ring
Material: EPDM

Fittings
Metal material: Stainless steel



3-Color Display High-Precision Digital Pressure Switch ZSE20□(F)/ISE20□ Series



Port thread
Material: Stainless steel

* A copper material is used for the lead wires.

Pilot Operated 2-Port Solenoid Valve 25A-VXD Series

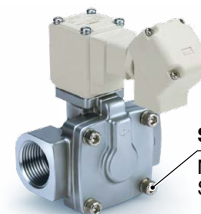

Screw
Material: Stainless steel

* A copper material is used for the solenoid coils and lead wires.

Solid State Auto Switch D-M9□-900 Series

Mounting screw
Material: Stainless steel



* A copper material is used for the lead wires.

Electric Actuator/Slider Type Ball Screw Drive 25A-LEFS Series

Bolts
Material: Stainless steel

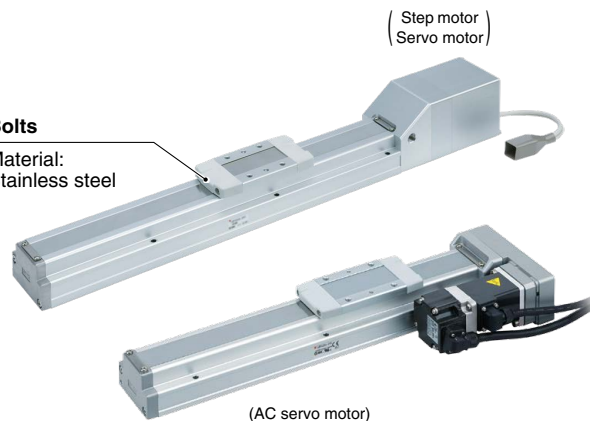

* Copper and zinc materials are used for the motors, cables, controllers/drivers.
* The motor magnet contains copper and/or zinc.

Electric Actuator/High Rigidity Slider Type Ball Screw Drive 25A-LEJS Series

Bolts
Material: Stainless steel

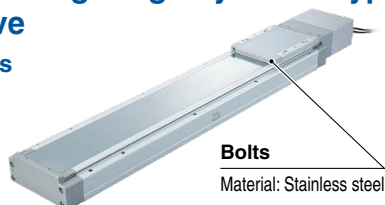

* Copper and zinc materials are used for the motors, cables, controllers/drivers.
* The motor magnet contains copper and/or zinc.

Electric Actuator/Rod Type 25A-LEY Series

Bushing
Material: Steel bearing alloy

Bolts
Material: Stainless steel

Bushing
Material: Steel bearing alloy

Bolts
Material: Stainless steel

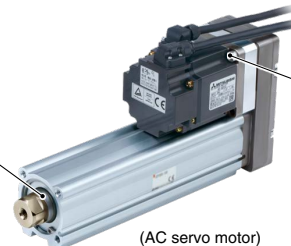

* Copper and zinc materials are used for the motors, cables, controllers/drivers. * The motor magnet contains copper and/or zinc.

Secondary Battery Manufacturing Process

Electrode Production Process

Same for both can types and laminate types

① Mixing and kneading machine

The proper amount of raw materials for positive or negative electrodes are mixed to make electrode slurry.

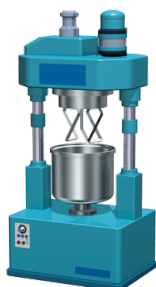
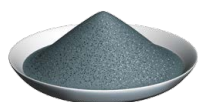

② Coating and rolling

Positive or negative electrode slurry is coated with a metallic foil made from aluminum, copper, etc. The coated slurry is then compressed with rollers continuously to enhance the density of the electrode sheet.

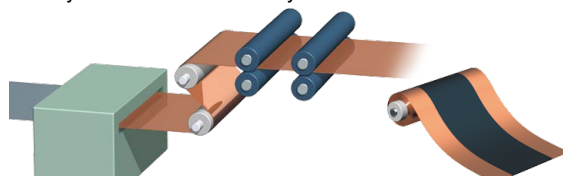

Electrode (Negative)

Cell Assembly Process

④ Winder (Winding)

The positive electrode sheet, negative electrode sheet, and separator sheets are laid on top of each other and wound to form a wound body.

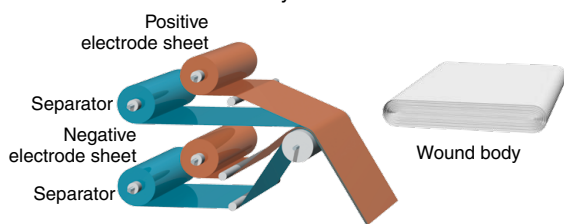

⑤ Attaching tabs and an insulating plate and inserting into a case

Current collecting tabs and an insulating plate are bonded to the wound body. It is then inserted into a case.

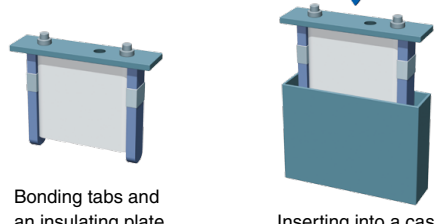

Can type

④ Punching electrodes

The rolled positive and negative electrodes are punched according to the battery size.

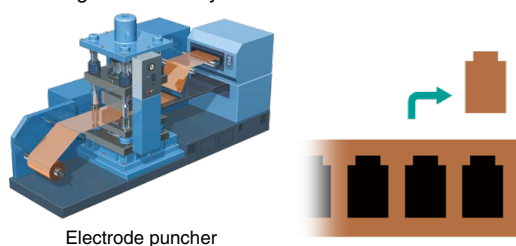

⑤ Stacking (Layering)

Positive and negative electrodes are stacked alternately and accurately at high speed with a separator inserted between them.

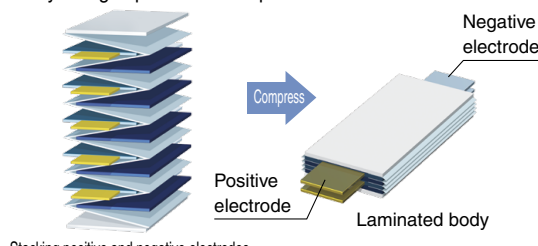

Laminate type

Inspection/Packaging Process

⑧ Charging/discharging and aging

Standard products are applicable.

Charging and discharging are repeated to activate batteries. Charged battery cells are then left for a certain period of time, and the initial deterioration of batteries is checked to detect defective products.



Activation of batteries

Aging

⑨ Packaging

Standard products are applicable.

Connected multiple cells are enclosed in a metallic case, and terminals are attached to form a module. Then, the connected multiple modules with a sensor and a controller are enclosed in a case to form a battery pack.

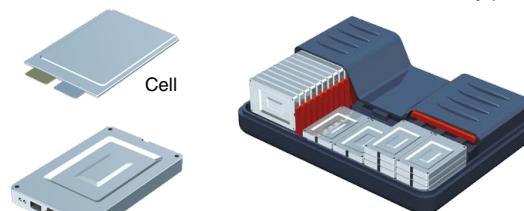

Module

Pack

Same for both can types and laminate types

3 Slitting

The electrode sheet and separator are cut to the cell width.

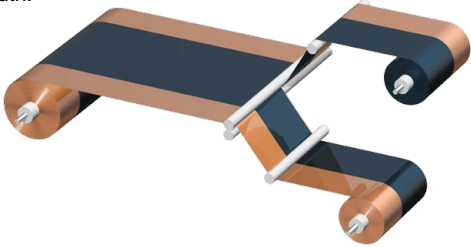

6 Welding cell lid and pouring electrolytic solution

The electrode and lid are laser-welded, and then the entire periphery of the cell case and lid is welded. Electrolytic solution is poured into the cell.



Welding cell lid

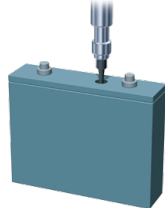

Pouring electrolytic solution

7 Pre-charging and welding infusion plug

Pre-charging (formation charging) is performed to remove the gas generated in the initial charging process, and then the infusion plug is welded to seal the cell.



Pre-charging

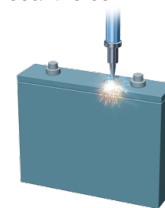

Welding infusion plug

6 Tab welding and lamination

Current collecting tabs are welded to the laminated body. The laminated body is wrapped with armoring material.

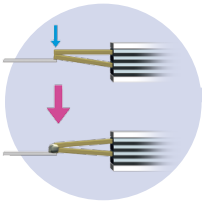

Tab welding

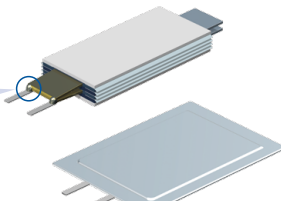

Lamination

7 Pre-charging and sealing cell

Pre-charging (formation charging) is performed to remove the gas generated in the initial charging process, and then heat is applied to seal the cell.

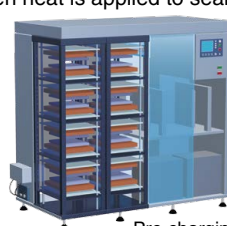

Pre-charging

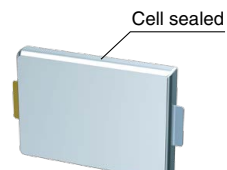

Sealing cell

