

● ISO Class 4*1 (ISO 14644-1)

- Built-in vacuum piping
- It is possible to mount the main body without removing the external cover, etc.
- Body-integrated linear guide specification

*1 Changes depending on the suction flow rate

Slider Type

Ball Screw Drive/11-LEFS Series

Incremental (Step Motor 24 VDC)

Incremental (Servo Motor 24 VDC)

p. 943

AC Servo Motor

p. 953, 955



Vacuum port

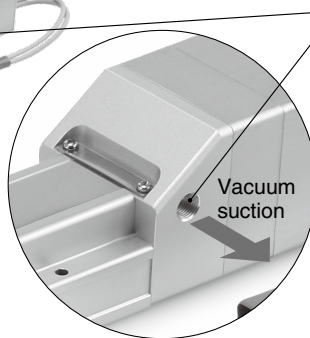

Vacuum suction from the vacuum port minimizes external particle generation from the ball screw and guide.

High Rigidity Slider Type

Ball Screw Drive/11-LEJS Series

AC Servo Motor

p. 967, 969



Vacuum port

* Port locations can be selected.

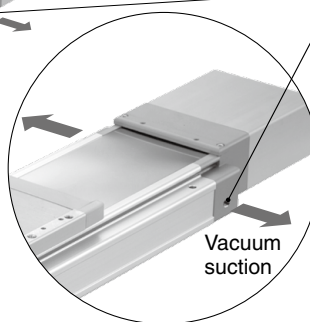

Vacuum suction from the vacuum port minimizes external particle generation from the ball screw and guide.

Support Guide/11-LEFG Series p. 961

The support guide was designed to support workpieces with significant overhang.

- As the dimensions are the same as the LEF series body, installation is simple and contributes to a reduction in installation and assembly labor.
- The standard-equipped seal bands prevent grease from splashing and external foreign matter from entering.

⚠ Caution

After installing the actuator on the drive side, align it with the support guide.

If the mounting flatness exceeds 0.1, install a floating mechanism separately on the workpiece installation surface (table).

Application example

LEF (Drive side)

Support guide

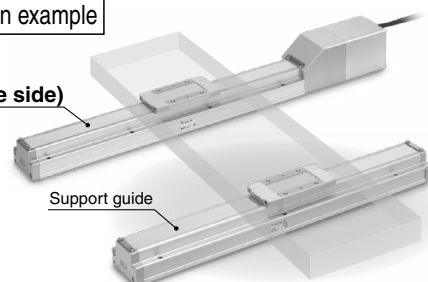

Slider Type

Ball Screw Drive/11-LEFS Series

Clean Room Specification

Particle Generation Characteristics

11-LEFS Series ▶ P. 943, 953, 955

Particle Generation Measuring Method

The particle generation data for SMC Clean Series are measured in the following test method.

■ Test Method (Example)

Operate the specimen that is placed in an ISO Class 5 equivalent clean bench, and measure the changes of the particle concentration over time until the number of cycles reaches the specified point.

■ Measuring Conditions

Measuring instrument	Description	Laser dust monitor (Automatic particle counter using the light scattering method)
	Minimum measurable particle diameter	0.1 μm
	Suction flow rate	28.3 L/min (ANR)
Setting conditions	Sampling time	5 min
	Interval time	55 min
	Sampling air flow	141.5 L (ANR)

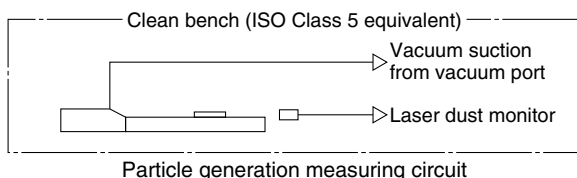

■ Evaluation Method

To obtain the measured values of particle concentration, the accumulated value*1 of particles captured every 5 minutes, by the laser dust monitor, is converted into the particle concentration in every 1 m³.

When determining particle generation grades, the 95% upper confidence limit of the average particle concentration (average value), when each specimen is operated at a specified number of cycles*2 is considered.

The plots in the graphs indicate the 95% upper confidence limit of the average particle concentration of particles with a diameter within the horizontal axis range.

*1 Sampling air flow rate: Number of particles contained in 141.5 L (ANR) of air

*2 Actuator: 1 million cycles

* The particle generation characteristics (pages 940 and 941) provide a guide for selection but is not guaranteed.

* When the suction flow rate is 0 L/min, the particle concentration is measured during operation without suction.

Particle Generation Characteristics
Step Motor (Servo/24 VDC), Servo Motor (24 VDC)

11-LEFS16 Speed 500 mm/s

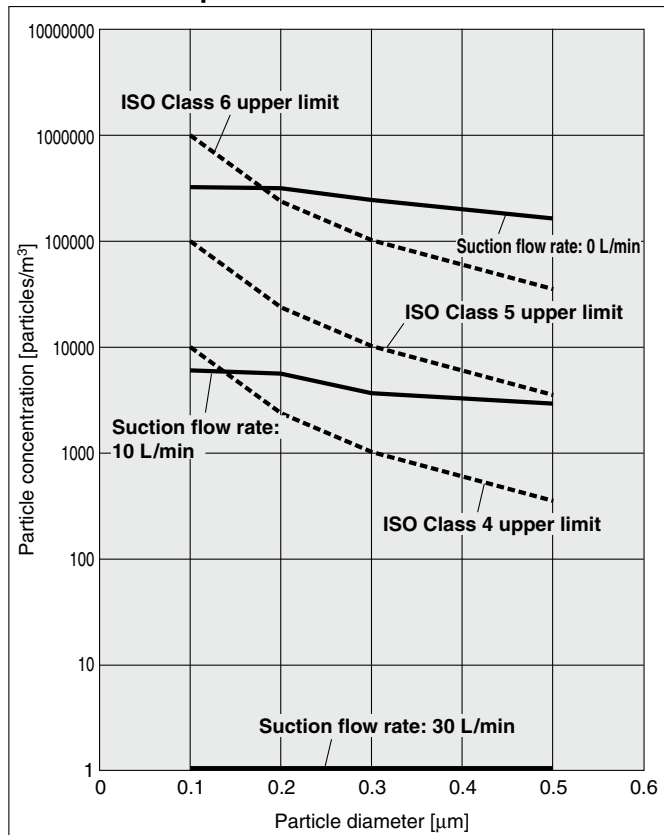

11-LEFS25 Speed 500 mm/s

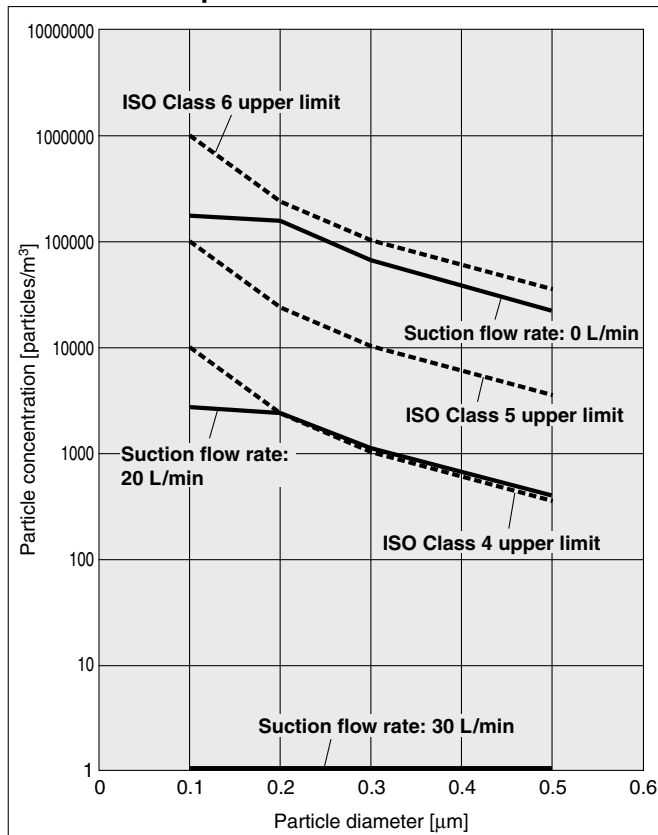

11-LEFS32 Speed 500 mm/s

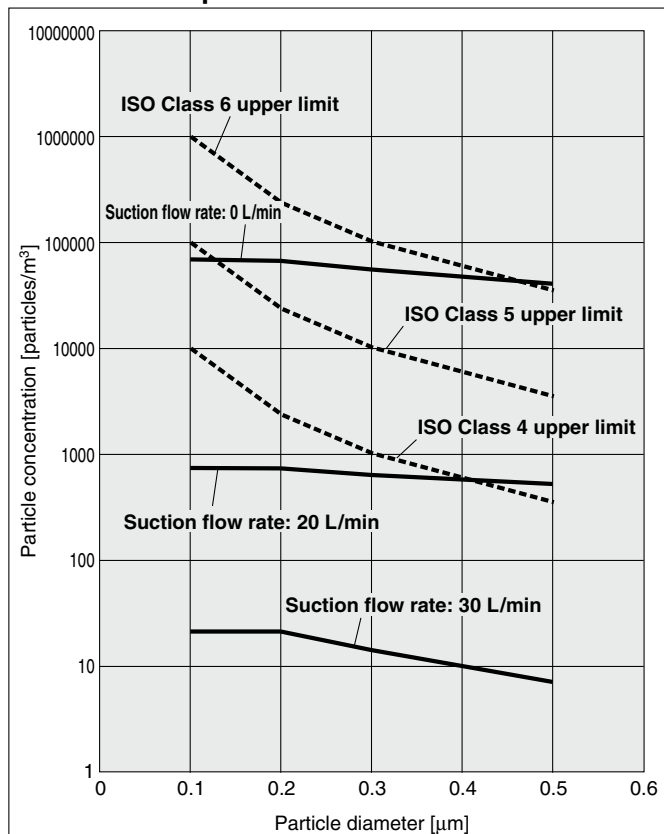

11-LEFS40 Speed 500 mm/s

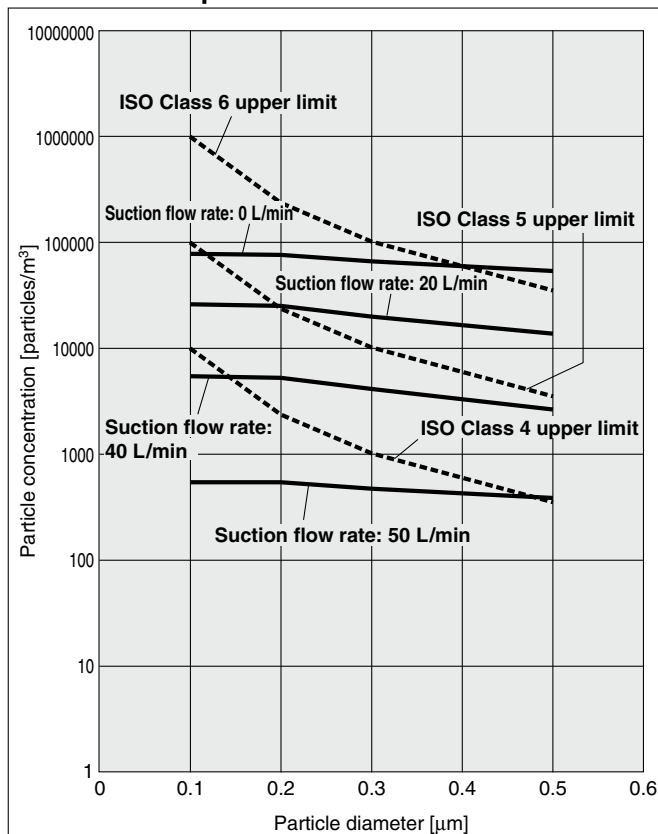

11-LEFS Series

AC Servo Motor

Clean Room Specification

Particle Generation Characteristics AC Servo Motor (100/200/400 W)

11-LEFS25 Speed 900 mm/s

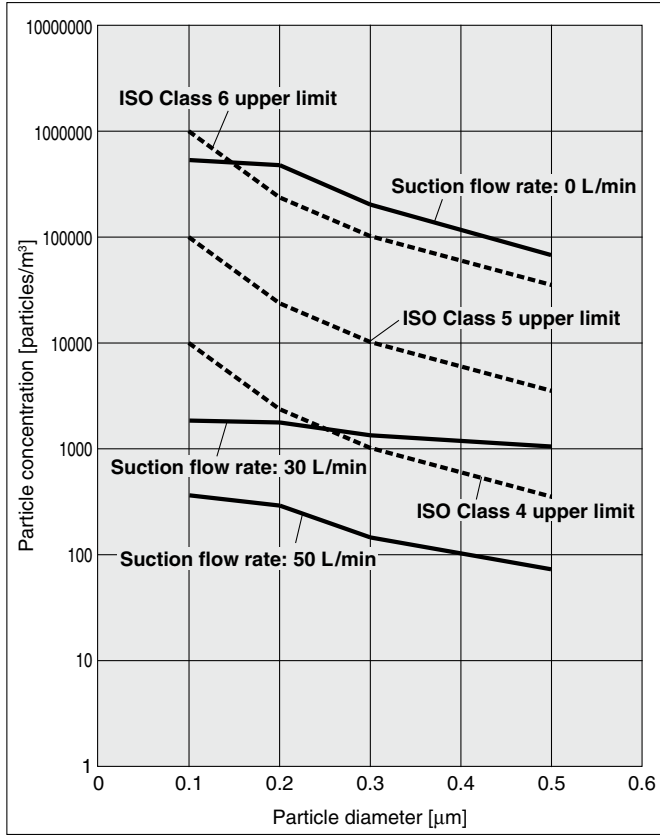

11-LEFS32 Speed 1000 mm/s

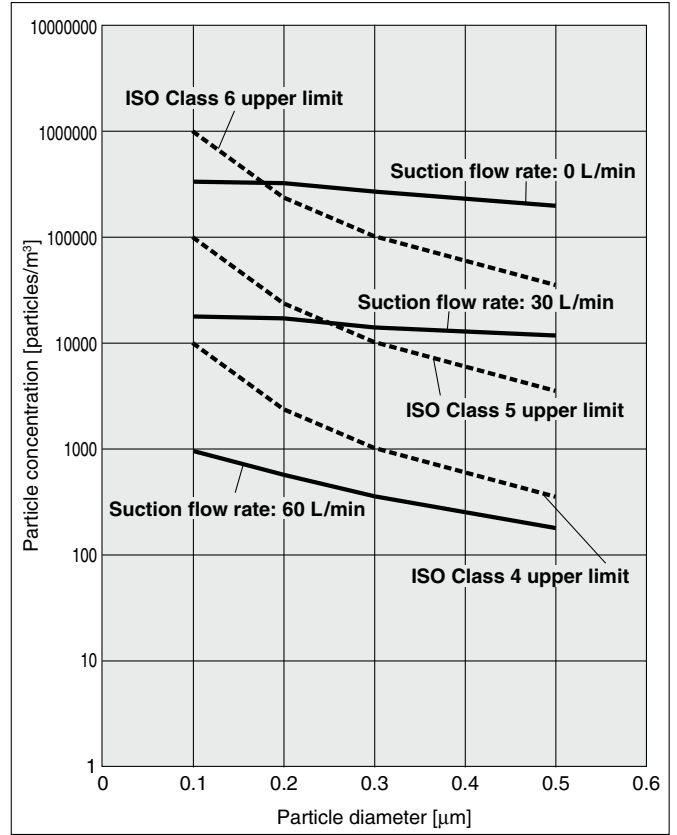

11-LEFS40 Speed 1000 mm/s

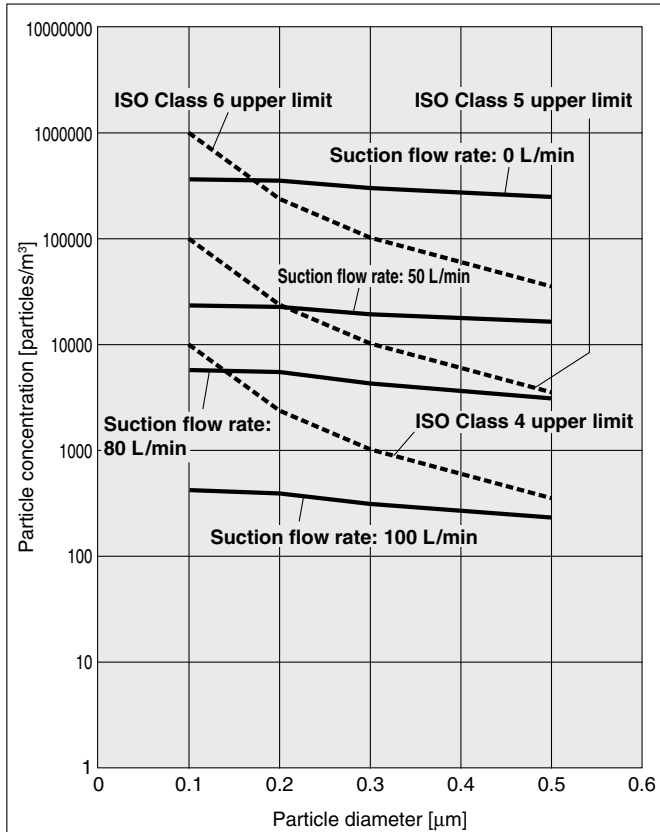

Slider Type Ball Screw Drive

Clean Room Specification



* For details, refer to page 1343 and onward.

11-LEFS Series LEFS16, 25, 32, 40

RoHS

Refer to page 113 for model selection and page 939 for particle generation characteristics.

How to Order

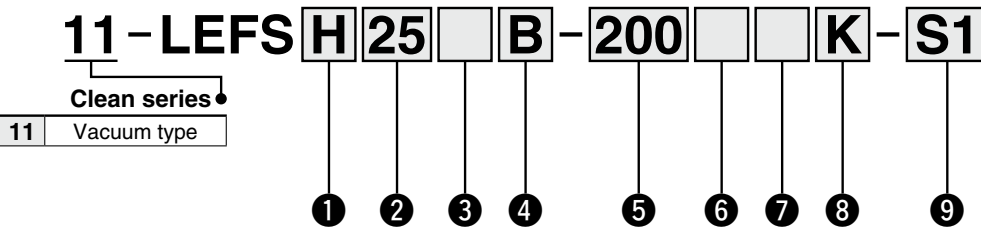
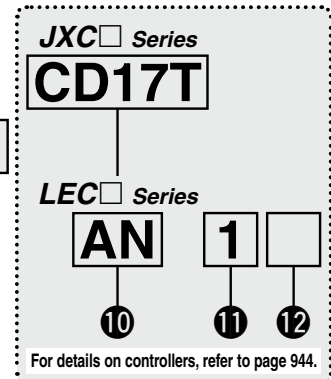
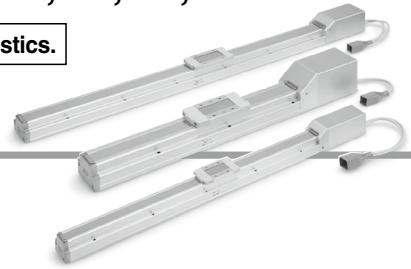

1 Accuracy

Nil	Basic type
H	High-precision type

2 Size

16
25
32
40

3 Motor type

Symbol	Type	Applicable size				Compatible controllers/drivers
		LEFS16	LEFS25	LEFS32	LEFS40	
Nil	Step motor (Servo/24 VDC)	●	●	●	●	JXC51 JXCEF JXC61 JXC9F JXCE1 JXCPF JXC91 JXCLF JXCP1 JXCD1 LEC P1 JXCL1 LEC PA JXCM1
A	Servo motor (24 VDC)	●	●	—	—	LECA6

4 Lead [mm]

Symbol	11-LEFS16	11-LEFS25	11-LEFS32	11-LEFS40
A	10	12	16	20
B	5	6	8	10

6 Motor option

Nil	Without option
B	With lock

5 Stroke*1 [mm]

Stroke	Size	Note
		Applicable stroke
50 to 500	16	50, 100, 150, 200, 250, 300, 350, 400, 450, 500
50 to 600	25	50, 100, 150, 200, 250, 300, 350, 400, 450, 500, 550, 600
50 to 800	32	50, 100, 150, 200, 250, 300, 350, 400, 450, 500, 550, 600, 650, 700, 750, 800
150 to 1000	40	150, 200, 250, 300, 350, 400, 450, 500, 550, 600, 650, 700, 750, 800, 850, 900, 950, 1000

7 Vacuum port*2

Nil	Left
R	Right

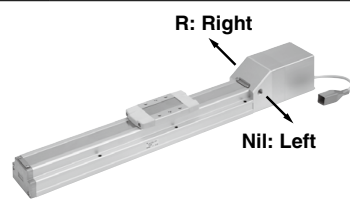

8 Positioning pin hole

Nil	Housing B bottom*3	
K	Body bottom 2 locations	

9 Actuator cable type/length*5

Standard cable [m]		Robotic cable [m]	
Nil	None	R1	1.5 RA 10*4
S1	1.5*7	R3	3 RB 15*4
S3	3*7	R5	5 RC 20*4
S5	5*7	R8	8*4

Support Guide/11-LEFG Series
The support guide was designed to support workpieces with significant overhang.
p. 961



Slider Type Ball Screw Drive **11-LEFS Series**

Incremental (Step Motor 24 VDC)

Incremental (Servo Motor 24 VDC)

Clean Room Specification

JXC Series (For details, refer to page 945.)

10 Controller

Nil	Without controller
C□1□□	With controller

C D 1 7 T

Interface (Communication protocol/Input/Output)

Symbol	Type	Number of axes, Special specification	
		Standard	With STO sub-function
5	Parallel input (NPN)	●	
6	Parallel input (PNP)	●	
E	EtherCAT	●	●
9	EtherNet/IP™	●	●
P	PROFINET	●	●
D	DeviceNet®	●	
L	IO-Link	●	●
M	CC-Link	●	

Mounting

7	Screw mounting
8*11	DIN rail

Number of axes, Special specification

Symbol	Number of axes	Specification
1	Single axis	Standard
F	Single axis	With STO sub-function

Communication plug connector, I/O cable*12

Symbol	Type	Applicable interface
Nil	Without accessory	—
S	Straight type communication plug connector	DeviceNet®
T	T-branch type communication plug connector	CC-Link Ver. 1.10
1	I/O cable (1.5 m)	Parallel input (NPN) Parallel input (PNP)
3	I/O cable (3 m)	
5	I/O cable (5 m)	



LEC Series (For details, refer to page 945.)

AN 1 □

10 11 12

10 Controller/Driver type*6

Nil	Without controller/driver	
6N	LECA6	NPN
6P	(Step data input type)	PNP
1N	LECP1*7	NPN
1P	(Programless type)	PNP
AN	LECPA*7 *8	NPN
AP	(Pulse input type)	PNP

11 I/O cable length*9

Nil	Without cable (Without communication plug connector)
1	1.5 m
3	3 m*10
5	5 m*10

12 Controller/Driver mounting

Nil	Screw mounting
D	DIN rail*11



- *1 Please contact SMC for non-standard strokes as they are produced as special orders.
- *2 Vacuum piping is only built in on the vacuum port side selected at the time of purchase. Note that after purchase, if suction is used on the port on the opposite side, the particle generation characteristics stated in the catalog may not apply. To make any changes after purchase, be sure to contact SMC.
- *3 Refer to the body mounting example on page 280 for the mounting method.
- *4 Produced upon receipt of order (Robotic cable only)
- *5 The standard cable should only be used on fixed parts. For use on moving parts, select the robotic cable. Refer to the [Web Catalog](#) if only the actuator cable is required.
- *6 For details on controllers/drivers and compatible motors, refer to the

- compatible controllers/drivers on the next page.
- *7 Only available for the motor type "Step motor"
- *8 When pulse signals are open collector, order the current limiting resistor (LEC-PA-R-□) on page 1062 separately.
- *9 When "Without controller/driver" is selected for controller/driver types, I/O cable cannot be selected. If an I/O cable is required, refer to the cable for the LECA6 ([Web Catalog](#)), LECP1 ([Web Catalog](#)), or LECPA ([Web Catalog](#)).
- *10 When "Pulse input type" is selected for controller/driver types, pulse input usable only with differential. Only 1.5 m cables usable with open collector
- *11 The DIN rail is not included. It must be ordered separately.
- *12 Select "Nil," "S," or "T" for DeviceNet®, CC-Link, or parallel input. Select "Nil," "1," "3," or "5" for parallel input.

⚠ Caution

[CE/UKCA-compliant products]

① EMC compliance was tested by combining the electric actuator LEF series and the controller LEC/JXC series.

The EMC depends on the configuration of the customer's control panel and the relationship with other electrical equipment and wiring. Therefore, compliance with the EMC directive cannot be certified for SMC components incorporated into the customer's equipment under actual operating conditions. As a result, it is necessary for the customer to verify compliance with the EMC directive for the machinery and equipment as a whole.

② For the incremental (servo motor 24 VDC) specification, EMC compliance was tested by installing a noise filter set (LEC-NFA). Refer to page 1037 for the noise filter set. Refer to the LECA series Operation Manual for installation.

[UL-compliant products (For the LEC series)]

When compliance with UL is required, the electric actuator and controller/driver should be used with a UL1310 Class 2 power supply.

The actuator and controller/driver are sold as a package.

Confirm that the combination of the controller/driver and actuator is correct.

<Check the following before use.>

- ① Check the actuator label for the model number. This number should match that of the controller/driver.
- ② Check that the Parallel I/O configuration matches (NPN or PNP).

LEFS16A-400

NPN

①

②

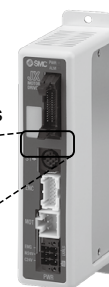

* Refer to the Operation Manual for using the products. Please download it via our website: <https://www.smcworld.com>





11-LEFS Series











Incremental (Step Motor 24 VDC)

Incremental (Servo Motor 24 VDC)

Clean Room Specification

Compatible Controllers/Drivers

Type	Step data input type	Step data input type	Programless type	Pulse input type
				
Series	JXC51 JXC61	LECA6	LECP1	LECPA
Features	Parallel I/O	Parallel I/O	Capable of setting up operation (step data) without using a PC or teaching box	Operation by pulse signals
Compatible motor	Step motor (Servo/24 VDC)	Servo motor (24 VDC)	Step motor (Servo/24 VDC)	
Max. number of step data	64 points		14 points	—
Power supply voltage	24 VDC			
Reference page	1017	1031	1042	1057

Type	EtherCAT direct input type	EtherCAT direct input type with STO sub-function	EtherNet/IP™ direct input type	EtherNet/IP™ direct input type with STO sub-function	PROFINET direct input type	PROFINET direct input type with STO sub-function	DeviceNet® direct input type	IO-Link direct input type	IO-Link direct input type with STO sub-function	CC-Link direct input type
										
Series	JXCE1	JXCEF	JXC91	JXC9F	JXCP1	JXC9F	JXCD1	JXCL1	JXCLF	JXCM1
Features	EtherCAT direct input	EtherCAT direct input with STO sub-function	EtherNet/IP™ direct input	EtherNet/IP™ direct input with STO sub-function	PROFINET direct input	PROFINET direct input with STO sub-function	DeviceNet® direct input	IO-Link direct input	IO-Link direct input with STO sub-function	CC-Link direct input
Compatible motor	Step motor (Servo/24 VDC)									
Max. number of step data	64 points									
Power supply voltage	24 VDC									
Reference page	1063									

Specifications

Step Motor (Servo/24 VDC)

Model		11-LEFS16		11-LEFS25		11-LEFS32		11-LEFS40			
Actuator specifications	Stroke [mm] ^{*1}	50 to 500		50 to 600		50 to 800		150 to 1000			
	Work load [kg] ^{*2}	Horizontal	JXC□1/JXC□F/LECP1	14	15	25	30	45	50	55	65
			LECPA/JXC□ ₃	9	10	20	20	40	45	50	60
		Vertical		2	4	7.5	15	10	20	2	23
	Speed [mm/s] ^{*2}	10 to 500		5 to 250	12 to 500	6 to 250	16 to 500	8 to 250	20 to 500	10 to 250	
	Max. acceleration/deceleration [mm/s ²]	3000									
	Positioning repeatability [mm]	Basic type		±0.02							
		High-precision type		±0.015							
	Lost motion [mm] ^{*3}	Basic type		0.1 or less							
		High-precision type		0.05 or less							
	Lead [mm]		10	5	12	6	16	8	20	10	
	Impact/Vibration resistance [m/s ²] ^{*4}	50/20									
	Actuation type	Ball screw									
	Guide type	Linear guide									
	Static allowable moment ^{*5} [N·m]	Mep (Pitching)		10		27		46		110	
Mey (Yawing)		10		27		46		110			
Mer (Rolling)		20		52		101		207			
Operating temperature range [°C]	5 to 40										
Operating humidity range [%RH]	90 or less (No condensation)										
Cleanliness class ^{*6}	ISO Class 4 (ISO 14644-1)										
Grease	Ball screw /Linear guide portion		Low particle generation grease								
Electric specifications	Motor size	□28		□42		□56.4					
	Motor type	Step motor (Servo/24 VDC)									
	Encoder	Incremental									
	Power supply voltage [V]	24 VDC ±10%									
Power [W] ^{*7 *9}	Max. power 51		Max. power 57		Max. power 123		Max. power 141				
Lock unit specifications	Type ^{*8}	Non-magnetizing lock									
	Holding force [N]	20	39	78	157	108	216	113	225		
	Power [W] ^{*9}	2.9		5		5		5			
Rated voltage [V]	24 VDC ±10%										

*1 Please contact SMC for non-standard strokes as they are produced as special orders.

*2 Speed changes according to the controller/driver type and work load. Check the "Speed-Work Load Graph (Guide)" on pages 114 and 115. Furthermore, if the cable length exceeds 5 m, then it will decrease by up to 10% for each 5 m.

*3 A reference value for correcting errors in reciprocal operation

*4 Impact resistance: No malfunction occurred when the actuator was tested with a drop tester in both an axial direction and a perpendicular direction to the lead screw. (The test was performed with the actuator in the initial state.)

Vibration resistance: No malfunction occurred in a test ranging between 45 to 2000 Hz. The test was performed in both an axial direction and a perpendicular direction to the lead screw. (The test was performed with the actuator in the initial state.)

*5 The static allowable moment is the amount of static moment which can be applied to the actuator when it is stopped.

If the product is exposed to impact or repeated load, be sure to take adequate safety measures when using the product.

*6 The amount of particle generation changes according to the operating conditions and suction flow rate. Refer to the particle generation characteristics for details.

*7 Indicates the max. power during operation (including the controller)

This value can be used for the selection of the power supply.

*8 With lock only

*9 For an actuator with lock, add the power for the lock.

11-LEFS Series

Incremental (Step Motor 24 VDC)

Incremental (Servo Motor 24 VDC)

Clean Room Specification

Specifications

Servo Motor (24 VDC)

Model		11-LEFS16A		11-LEFS25A		
Actuator specifications	Stroke [mm] ^{*1}	50 to 500		50 to 600		
	Work load ^{*2} [kg]	Horizontal	7	10	11	18
		Vertical	2	4	2.5	5
	Speed [mm/s] ^{*2}	1 to 500	1 to 250	2 to 500	1 to 250	
	Max. acceleration/deceleration [mm/s ²]	3000				
	Positioning repeatability [mm]	Basic type	±0.02			
		High-precision type	±0.015			
	Lost motion ^{*3} [mm]	Basic type	0.1 or less			
		High-precision type	0.05 or less			
	Lead [mm]	10	5	12	6	
	Impact/Vibration resistance [m/s ²] ^{*4}	50/20				
	Actuation type	Ball screw				
	Guide type	Linear guide				
	Static allowable moment ^{*5} [N·m]	Mep (Pitching)	10		27	
		Mey (Yawing)	10		27	
Mer (Rolling)		20		52		
Operating temperature range [°C]	5 to 40					
Operating humidity range [%RH]	90 or less (No condensation)					
Cleanliness class ^{*6}	ISO Class 4 (ISO 14644-1)					
Grease Ball screw/Linear guide portion	Low particle generation grease					
Electric specifications	Motor size	□28		□42		
	Motor output [W]	30		36		
	Motor type	Servo motor (24 VDC)				
	Encoder	Incremental				
	Power supply voltage [V]	24 VDC ±10%				
Lock unit specifications	Power [W] ^{*7 *9}	Max. power 70		Max. power 113		
	Type ^{*8}	Non-magnetizing lock				
	Holding force [N]	20	39	78	157	
Power [W] ^{*9}	2.9		5			
Rated voltage [V]	24 VDC ±10%					

*1 Please contact SMC for non-standard strokes as they are produced as special orders.

*2 Check the "Speed-Work Load Graph (Guide)" on page 117 for details. Furthermore, if the cable length exceeds 5 m, then it will decrease by up to 10% for each 5 m.

*3 A reference value for correcting errors in reciprocal operation

*4 Impact resistance: No malfunction occurred when the actuator was tested with a drop tester in both an axial direction and a perpendicular direction to the lead screw. (The test was performed with the actuator in the initial state.)

Vibration resistance: No malfunction occurred in a test ranging between 45 to 2000 Hz. The test was performed in both an axial direction and a perpendicular direction to the lead screw. (The test was performed with the actuator in the initial state.)

*5 The static allowable moment is the amount of static moment which can be applied to the actuator when it is stopped.

If the product is exposed to impact or repeated load, be sure to take adequate safety measures when using the product.

*6 The amount of particle generation changes according to the operating conditions and suction flow rate. Refer to the particle generation characteristics for details.

*7 Indicates the max. power during operation (including the controller)

This value can be used for the selection of the power supply.

*8 With lock only

*9 For an actuator with lock, add the power for the lock.

Weight

Series	11-LEFS16									
Stroke [mm]	50	100	150	200	250	300	350	400	450	500
Product weight [kg]	0.83	0.90	0.98	1.05	1.13	1.20	1.28	1.35	1.43	1.50
Additional weight with lock [kg]	0.12									

Series	11-LEFS25											
Stroke [mm]	50	100	150	200	250	300	350	400	450	500	550	600
Product weight [kg]	1.70	1.84	1.98	2.12	2.26	2.40	2.54	2.68	2.82	2.96	3.10	3.24
Additional weight with lock [kg]	0.26											

Series	11-LEFS32															
Stroke [mm]	50	100	150	200	250	300	350	400	450	500	550	600	650	700	750	800
Product weight [kg]	3.15	3.35	3.55	3.75	3.95	4.15	4.35	4.55	4.75	4.95	5.15	5.35	5.55	5.75	5.95	6.15
Additional weight with lock [kg]	0.53															

Series	11-LEFS40																			
Stroke [mm]	150	200	250	300	350	400	450	500	550	600	650	700	750	800	850	900	950	1000		
Product weight [kg]	5.37	5.65	5.93	6.21	6.49	6.77	7.15	7.33	7.61	7.89	8.17	8.45	8.75	9.01	9.29	9.57	9.85	10.13		
Additional weight with lock [kg]	0.53																			

Dimensions: Ball Screw Drive

11-LEFS16

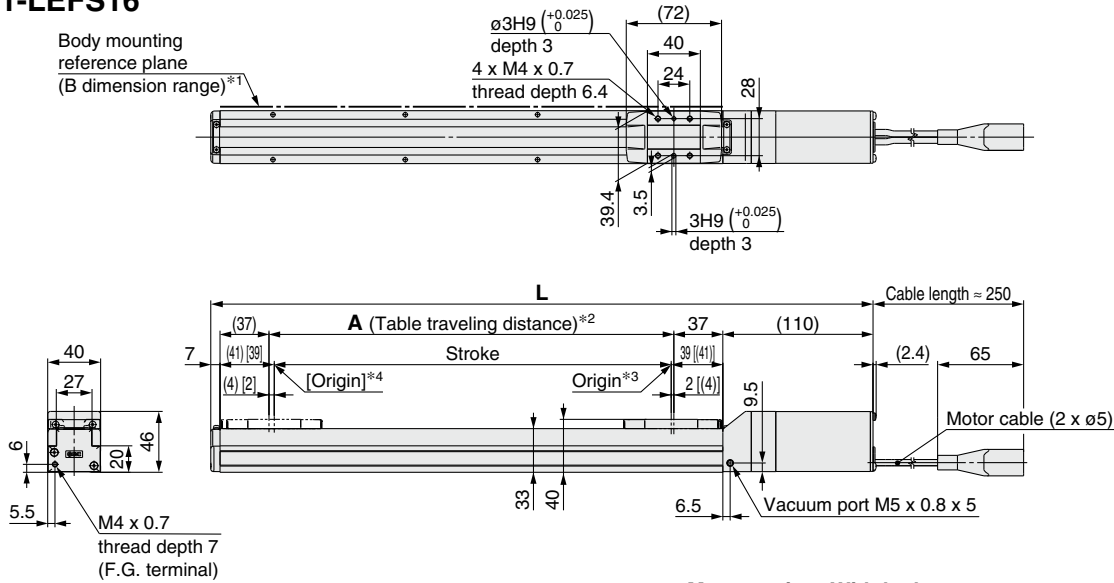

Motor option: With lock

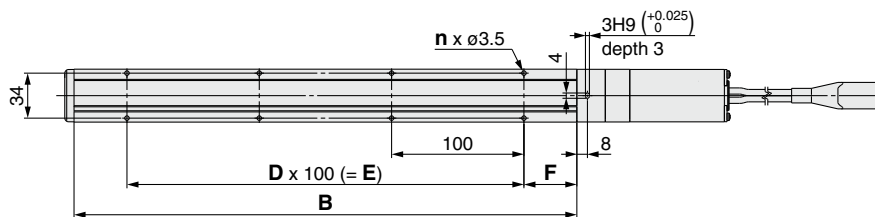
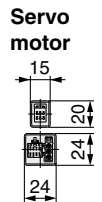
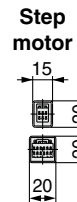
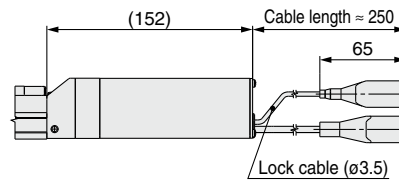

Positioning pin hole*5 (Option): Body bottom

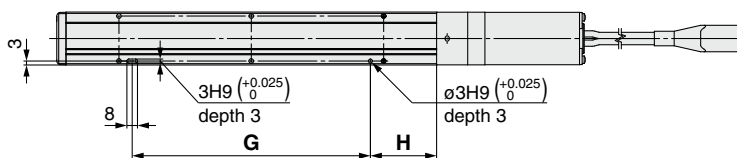

- *1 When mounting the actuator using the body mounting reference plane, set the height of the opposite surface or pin to be 2 mm or more because of round chamfering. (Recommended height: 5 mm)
In addition, be aware that surfaces other than the body mounting reference plane (B dimension range) may slightly protrude from the body mounting reference plane. Be sure to provide a clearance of 1 mm or more to avoid interference with workpieces, facilities, etc.
- *2 This is the distance within which the table can move when it returns to origin.
Make sure that workpieces mounted on the table do not interfere with other workpieces or the facilities around the table.
- *3 Position after returning to origin
- *4 [] for when the direction of return to origin has changed
- *5 When using the body bottom positioning pin holes, do not simultaneously use the housing B bottom pin hole.

Dimensions

Model	L		A	B	n	D	E	F	G	H	
	Without lock	With lock									
11-LEFS□16□-50□	247	289	56	130	4	—	—	40	15	80	25
11-LEFS□16□-100□	297	339	106	180	4	—	—		80	50	
11-LEFS□16□-150□	347	389	156	230	4	—	—		80	50	
11-LEFS□16□-200□	397	439	206	280	6	2	200		180	50	
11-LEFS□16□-250□	447	489	256	330	6	2	200		180	50	
11-LEFS□16□-300□	497	539	306	380	8	3	300		280	50	
11-LEFS□16□-350□	547	589	356	430	8	3	300		280	50	
11-LEFS□16□-400□	597	639	406	480	10	4	400		380	50	
11-LEFS□16□-450□	647	689	456	530	10	4	400		380	50	
11-LEFS□16□-500□	697	739	506	580	12	5	500		480	50	

11-LEFS Series

Incremental (Step Motor 24 VDC)

Incremental (Servo Motor 24 VDC)

Clean Room Specification

Dimensions: Ball Screw Drive

11-LEFS25

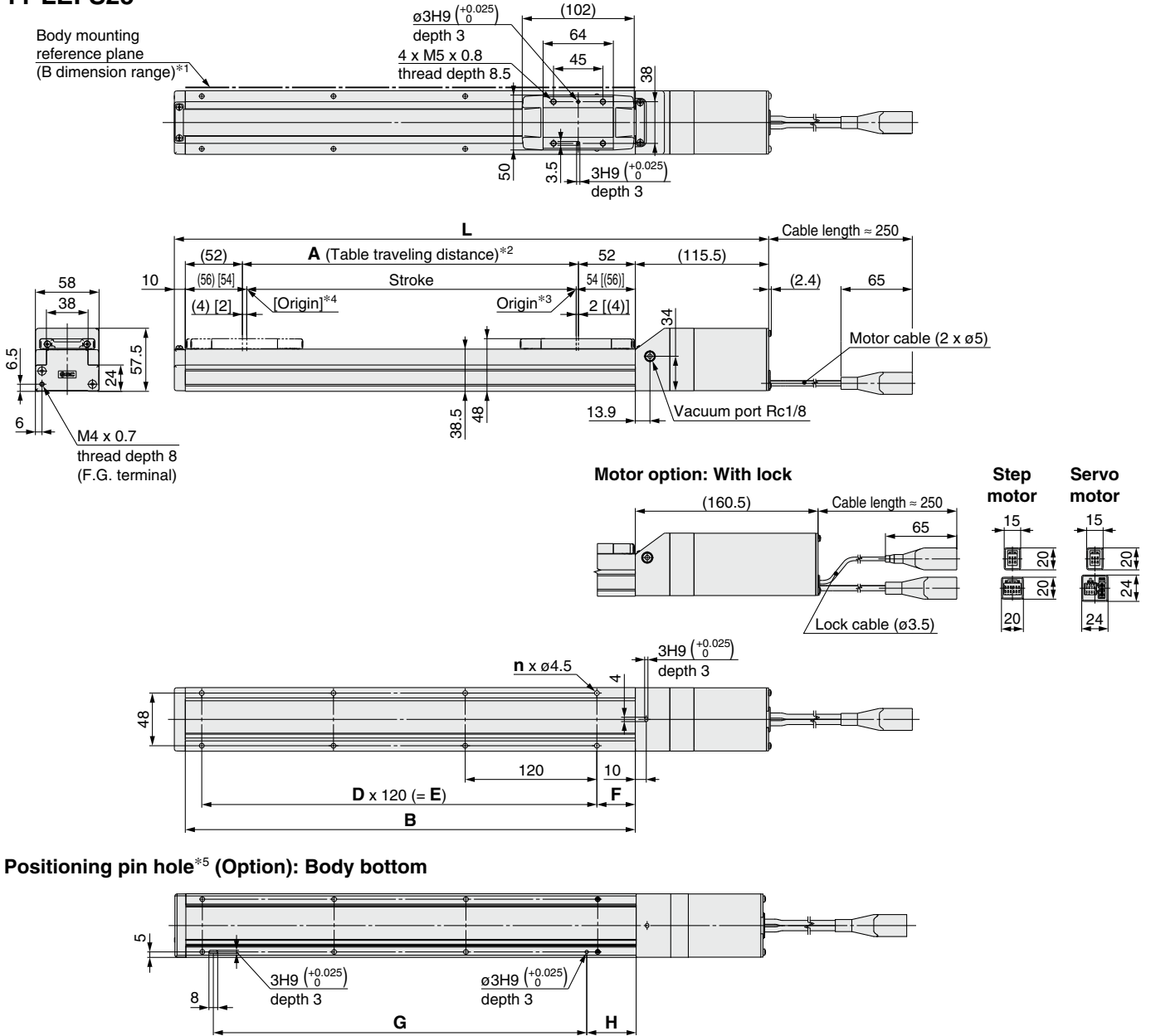

Positioning pin hole*5 (Option): Body bottom

- *1 When mounting the actuator using the body mounting reference plane, set the height of the opposite surface or pin to be 3 mm or more because of round chamfering. (Recommended height: 5 mm)
In addition, be aware that surfaces other than the body mounting reference plane (B dimension range) may slightly protrude from the body mounting reference plane. Be sure to provide a clearance of 1 mm or more to avoid interference with workpieces, facilities, etc.
- *2 This is the distance within which the table can move when it returns to origin. Make sure that workpieces mounted on the table do not interfere with other workpieces or the facilities around the table.
- *3 Position after returning to origin
- *4 [] for when the direction of return to origin has changed
- *5 When using the body bottom positioning pin holes, do not simultaneously use the housing B bottom pin hole.

Dimensions

Model	L		A	B	n	D	E	F	G	H	
	Without lock	With lock									
11-LEFS□25□-50□	285.5	330.5	56	160	4	—	—	35	20	100	30
11-LEFS□25□-100□	335.5	380.5	106	210	4	—	—			100	45
11-LEFS□25□-150□	385.5	430.5	156	260	4	—	—			100	45
11-LEFS□25□-200□	435.5	480.5	206	310	6	2	240			220	45
11-LEFS□25□-250□	485.5	530.5	256	360	6	2	240			220	45
11-LEFS□25□-300□	535.5	580.5	306	410	8	3	360			340	45
11-LEFS□25□-350□	585.5	630.5	356	460	8	3	360			340	45
11-LEFS□25□-400□	635.5	680.5	406	510	8	3	360			340	45
11-LEFS□25□-450□	685.5	730.5	456	560	10	4	480			460	45
11-LEFS□25□-500□	735.5	780.5	506	610	10	4	480			460	45
11-LEFS□25□-550□	785.5	830.5	556	660	12	5	600			580	45
11-LEFS□25□-600□	835.5	880.5	606	710	12	5	600	580	45		

Dimensions: Ball Screw Drive

11-LEFS32

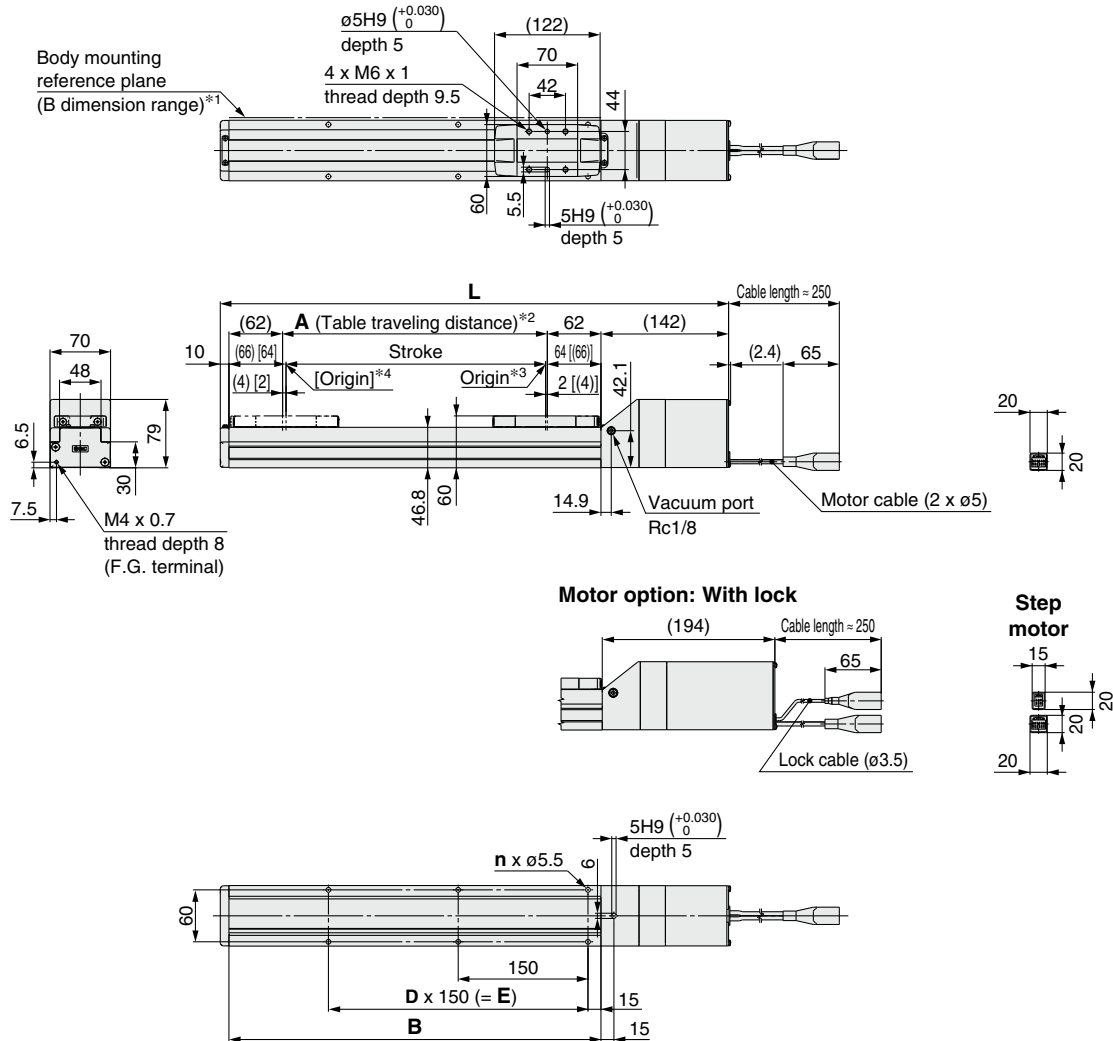

Positioning pin hole*5 (Option): Body bottom

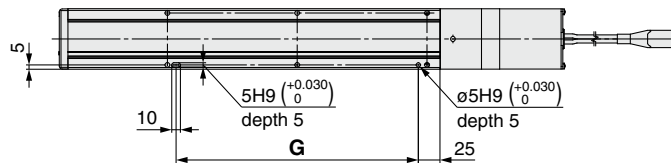

- *1 When mounting the actuator using the body mounting reference plane, set the height of the opposite surface or pin to be 3 mm or more because of round chamfering. (Recommended height: 5 mm)
In addition, be aware that surfaces other than the body mounting reference plane (B dimension range) may slightly protrude from the body mounting reference plane. Be sure to provide a clearance of 1 mm or more to avoid interference with workpieces, facilities, etc.
- *2 This is the distance within which the table can move when it returns to origin.
Make sure that workpieces mounted on the table do not interfere with other workpieces or the facilities around the table.
- *3 Position after returning to origin
- *4 [] for when the direction of return to origin has changed
- *5 When using the body bottom positioning pin holes, do not simultaneously use the housing B bottom pin hole.

Dimensions

[mm]

Model	L		A	B	n	D	E	G
	Without lock	With lock						
11-LEFS□32□-50□	332	384	56	180	4	—	—	130
11-LEFS□32□-100□	382	434	106	230	4	—	—	130
11-LEFS□32□-150□	432	484	156	280	4	—	—	130
11-LEFS□32□-200□	482	534	206	330	6	2	300	280
11-LEFS□32□-250□	532	584	256	380	6	2	300	280
11-LEFS□32□-300□	582	634	306	430	6	2	300	280
11-LEFS□32□-350□	632	684	356	480	8	3	450	430
11-LEFS□32□-400□	682	734	406	530	8	3	450	430
11-LEFS□32□-450□	732	784	456	580	8	3	450	430
11-LEFS□32□-500□	782	834	506	630	10	4	600	580
11-LEFS□32□-550□	832	884	556	680	10	4	600	580
11-LEFS□32□-600□	882	934	606	730	10	4	600	580
11-LEFS□32□-650□	932	984	656	780	12	5	750	730
11-LEFS□32□-700□	982	1034	706	830	12	5	750	730
11-LEFS□32□-750□	1032	1084	756	880	12	5	750	730
11-LEFS□32□-800□	1082	1134	806	930	14	6	900	880

11-LEFS Series

Incremental (Step Motor 24 VDC)

Incremental (Servo Motor 24 VDC)

Clean Room Specification

Dimensions: Ball Screw Drive

11-LEFS40

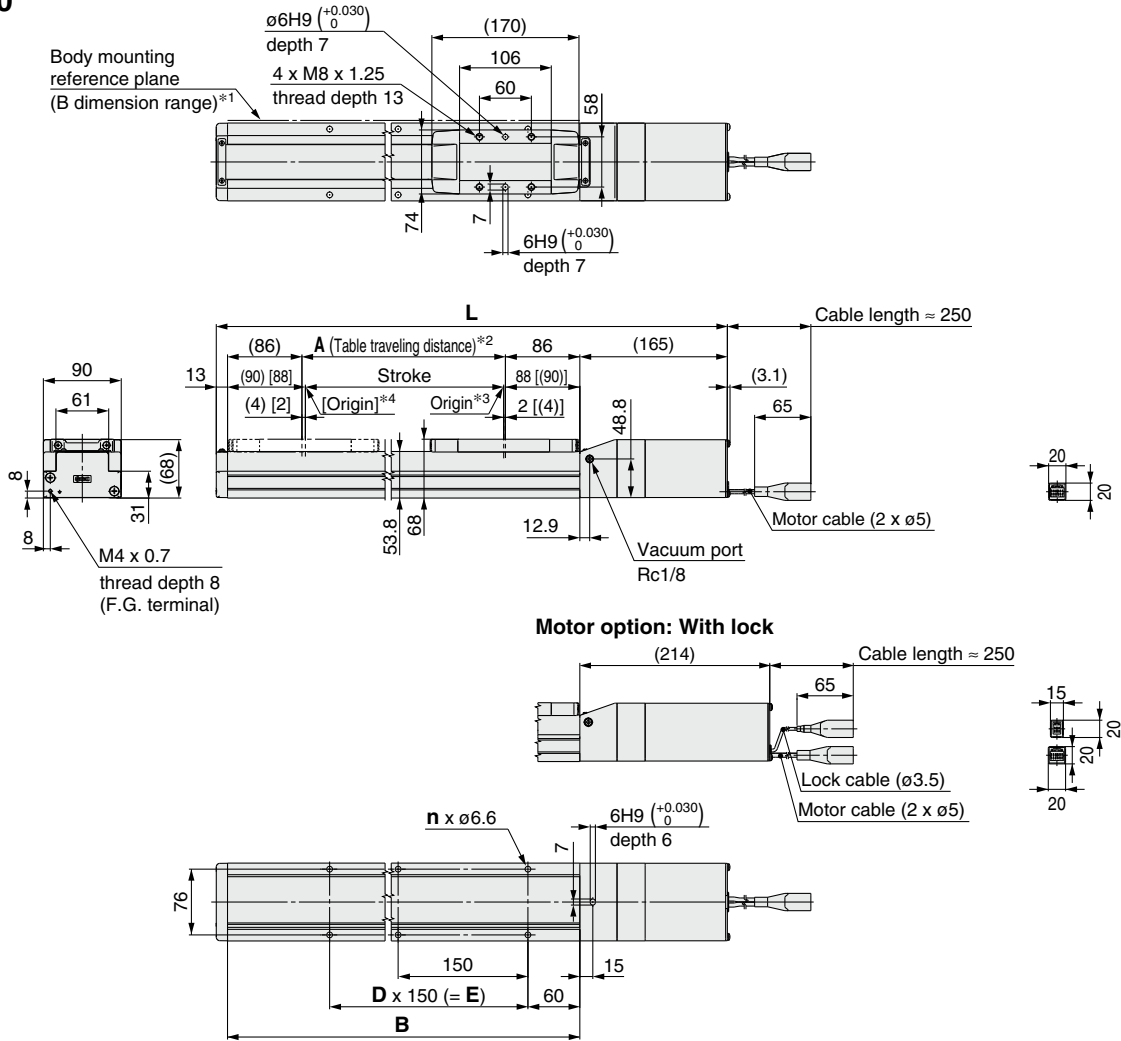

Positioning pin hole*5 (Option): Body bottom

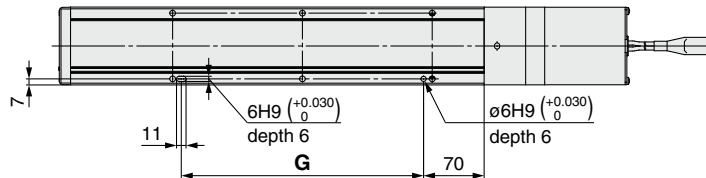

*1 When mounting the actuator using the body mounting reference plane, set the height of the opposite surface or pin to be 3 mm or more because of round chamfering. (Recommended height: 5 mm)
In addition, be aware that surfaces other than the body mounting reference plane (B dimension range) may slightly protrude from the body mounting reference plane. Be sure to provide a clearance of 1 mm or more to avoid interference with workpieces, facilities, etc.

*2 This is the distance within which the table can move when it returns to origin. Make sure that workpieces mounted on the table do not interfere with other workpieces or the facilities around the table.

*3 Position after returning to origin

*4 [] for when the direction of return to origin has changed

*5 When using the body bottom positioning pin holes, do not simultaneously use the housing B bottom pin hole.

Dimensions

Model	L		A	B	n	D	E	G
	Without lock	With lock						
11-LEFS□40□-150□	506	555	156	328	4	—	150	130
11-LEFS□40□-200□	556	605	206	378	6	2	300	280
11-LEFS□40□-250□	606	655	256	428	6	2	300	280
11-LEFS□40□-300□	656	705	306	478	6	2	300	280
11-LEFS□40□-350□	706	755	356	528	8	3	450	430
11-LEFS□40□-400□	756	805	406	578	8	3	450	430
11-LEFS□40□-450□	806	855	456	628	8	3	450	430
11-LEFS□40□-500□	856	905	506	678	10	4	600	580
11-LEFS□40□-550□	906	955	556	728	10	4	600	580
11-LEFS□40□-600□	956	1005	606	778	10	4	600	580
11-LEFS□40□-650□	1006	1055	656	828	12	5	750	730
11-LEFS□40□-700□	1056	1105	706	878	12	5	750	730
11-LEFS□40□-750□	1106	1155	756	928	12	5	750	730
11-LEFS□40□-800□	1156	1205	806	978	14	6	900	880
11-LEFS□40□-850□	1206	1255	856	1028	14	6	900	880
11-LEFS□40□-900□	1256	1305	906	1078	14	6	900	880
11-LEFS□40□-950□	1306	1355	956	1128	16	7	1050	1030
11-LEFS□40□-1000□	1356	1405	1006	1178	16	7	1050	1030

Slider Type Ball Screw Drive

Clean Room Specification

11-LEFS Series LEFS25, 32, 40

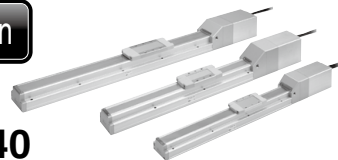

Refer to page 121 for model selection and page 939 for particle generation characteristics.



* For details, refer to page 1343 and onward.

LECY □ Series ▶ p. 955

How to Order

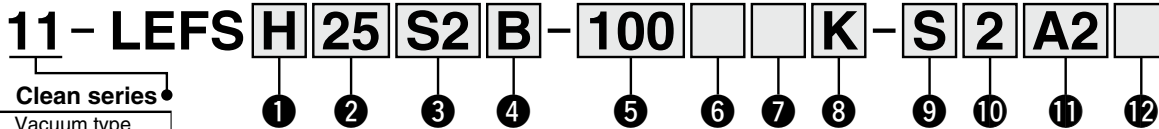

① Accuracy

Nil	Basic type
H	High-precision type

② Size

25
32
40

④ Lead [mm]

Symbol	11-LEFS25	11-LEFS32	11-LEFS40
A	12	16	20
B	6	8	10

⑤ Stroke [mm]*3

50	50
to	to
1000	1000

*3 For details, refer to the applicable stroke table below.

⑥ Motor option

Nil	Without option
B	With lock

③ Motor type

Symbol	Type	Output [W]	② Size	① Driver type	Compatible drivers
S2*1	AC servo motor (Incremental encoder)	100	25	A1/A2	LECSA□-S1
S3		200	32	A1/A2	LECSA□-S3
S4		400	40	A2	LECSA2-S4
T6*2	AC servo motor (Absolute encoder)	100	25	B2	LECSB2-T5
T7				C2	LECS2-T5
				S2	LECSS2-T5
		T8	B2	LECSB2-T7	
C2			LECS2-T7		
S2			LECSS2-T7		
T8	400	40	B2	LECSB2-T8	
			C2	LECS2-T8	
			S2	LECSS2-T8	

*1 For motor type S2, the compatible driver part number suffix is S1.

*2 For motor type T6, the compatible driver part number is LECS2□-T5.

⑨ Cable type*8, *9

Nil	Without cable
S	Standard cable
R	Robotic cable

*8 A motor cable and encoder cable are included with the product. (A lock cable is also included if motor option "B: With lock" is selected.)

*9 Standard cable entry direction is "(B) Counter axis side." (Refer to page 1123 for details.)

⑩ Cable length [m]*10

Nil	Without cable
2	2 m
5	5 m
A	10 m

*10 The length of the encoder, motor, and lock cables are the same.

⑧ Positioning pin hole

Nil	Housing B bottom*7	
K	Body bottom 2 locations	

*7 Refer to the body mounting example on page 280 for the mounting method.

⑪ Driver type*11

	Compatible drivers	Power supply voltage [V]	Size		
			25	32	40
Nil	Without driver	—	●	●	●
A1	LECSA1-S□	100 to 120	●	●	—
A2	LECSA2-S□	200 to 230	●	●	●
B2	LECSB2-T□	200 to 240	●	●	●
C2	LECS2-T□	200 to 230	●	●	●
S2	LECSS2-T□	200 to 240	●	●	●

*11 When a driver type is selected, a cable is included. Select the cable type and cable length.
Example) S2S2: Standard cable (2 m) + Driver (LECSS2)
S2: Standard cable (2 m)
Nil: Without cable and driver

⑦ Vacuum port*5, *6

Nil	Left
R	Right
D	Both left and right

*5 Select "D" for the vacuum port for suction of 50 L/min (ANR) or more.

*6 Vacuum piping is only built in on the vacuum port side selected at the time of purchase. Note that after purchase, if suction is used on the port on the opposite side, the particle generation characteristics stated in the catalog may not apply. To make any changes after purchase, be sure to contact SMC.

R: Right

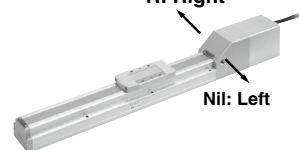

⑫ I/O cable length [m]*12

Nil	Without cable
H	Without cable (Connector only)
1	1.5

*12 When "Nil: Without driver" is selected for the driver type, only "Nil: Without cable" can be selected. Refer to page 1124 if an I/O cable is required. (Options are shown on page 1124.)

Applicable Stroke Table*4

Model	Stroke [mm]																			
	50	100	150	200	250	300	350	400	450	500	550	600	650	700	750	800	850	900	950	1000
11-LEFS25	●	●	●	●	●	●	●	●	●	●	●	●	●	●	●	●	●	●	●	●
11-LEFS32	●	●	●	●	●	●	●	●	●	●	●	●	●	●	●	●	●	●	●	●
11-LEFS40	—	—	●	●	●	●	●	●	●	●	●	●	●	●	●	●	●	●	●	●

*4 Please contact SMC for non-standard strokes as they are produced as special orders.

Support Guide/11-LEFG Series

The support guide was designed to support workpieces with significant overhang. [p. 961](#)

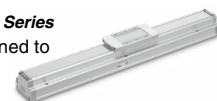

Compatible Drivers

Driver type	Pulse input type/ Positioning type	Pulse input type	CC-Link direct input type	SSCNET III/H type
Series	LECSA	LECSB-T	LECS2-T	LECSS-T
Number of point tables	Up to 7	Up to 255	Up to 255 (2 stations occupied)	—
Pulse input	○	○	—	—
Applicable network	—	—	CC-Link	SSCNET III/H
Control encoder	Incremental 17-bit encoder	Absolute 22-bit encoder	Absolute 18-bit encoder	Absolute 22-bit encoder
Communication function	USB communication	USB communication, RS422 communication	USB communication, RS422 communication	USB communication
Power supply voltage [V]	100 to 120 VAC (50/60 Hz) 200 to 230 VAC (50/60 Hz)	200 to 240 VAC (50/60 Hz)	200 to 230 VAC (50/60 Hz)	200 to 240 VAC (50/60 Hz)
Reference page	1109			

Specifications

11-LEFS25, 32, 40 AC Servo Motor

Model		11-LEFS25S2/T6		11-LEFS32S3/T7		11-LEFS40S4/T8			
Actuator specifications	Stroke [mm] ^{*1}	50 to 600		50 to 800		150 to 1000			
	Work load [kg] ^{*2}	Horizontal	20	20	40	45	50	60	
		Vertical	8	15	10	20	15	30	
	Max. speed [mm/s] ^{*3}	Stroke range	Up to 400	900	450	1000	500	1000	500
			401 to 500	720	360	1000	500	1000	500
			501 to 600	540	270	800	400	1000	500
			601 to 700	—	—	620	310	940	470
			701 to 800	—	—	500	250	760	380
			801 to 900	—	—	—	—	620	310
		901 to 1000	—	—	—	—	520	260	
	Max. acceleration/deceleration [mm/s ²]	5000 (Refer to pages 123 to 125 for limit according to work load and duty ratio.)							
	Positioning repeatability [mm]	Basic type	±0.02						
		High-precision type	±0.01						
	Lost motion [mm] ^{*4}	Basic type	0.1 or less						
		High-precision type	0.05 or less						
Lead [mm]		12	6	16	8	20	10		
Impact/Vibration resistance [m/s ²] ^{*5}	50/20								
Actuation type	Ball screw								
Guide type	Linear guide								
Static allowable moment ^{*6} [N·m]	Mep (Pitching)	27		46		110			
	Mey (Yawing)	27		46		110			
	Mer (Rolling)	52		101		207			
Operating temperature range [°C]	5 to 40								
Operating humidity range [%RH]	90 or less (No condensation)								
Cleanliness class ^{*7}	ISO Class 4 (ISO 14644-1) Class 10 (Fed.Std.209E)								
Grease	Ball screw /Linear guide portion	Low particle generation grease							
Motor output/Size		100 W/□40		200 W/□60		400 W/□60			
Motor type		AC servo motor (100/200 VAC)							
Encoder ^{*10}		Motor type S2, S3, S4: Incremental 17-bit encoder (Resolution: 131072 p/rev) Motor type T6, T7, T8: Absolute 22-bit encoder (Resolution: 4194304 p/rev) (For LECSB2-T□, LECS2-T□) Motor type T6, T7, T8: Absolute 18-bit encoder (Resolution: 262144 p/rev) (For LECSC2-T□)							
Power [W] ^{*8}		Max. power 445		Max. power 725		Max. power 1275			
Type ^{*9}		Non-magnetizing lock							
Holding force [N]		131	255	197	385	330	660		
Power [W] at 20°C		6.3		7.9		7.9			
Rated voltage [V]		24 VDC ⁰ / _{-10%}							

*1 Please contact SMC for non-standard strokes as they are produced as special orders.

*2 For details, refer to the "Speed-Work Load Graph (Guide)" on page 122.

*3 The allowable speed changes according to the stroke.

*4 A reference value for correcting errors in reciprocal operation

*5 Impact resistance: No malfunction occurred when the actuator was tested with a drop tester in both an axial direction and a perpendicular direction to the lead screw. (The test was performed with the actuator in the initial state.)

Vibration resistance: No malfunction occurred in a test ranging between 45 to 2000 Hz. The test was performed in both an axial direction and a perpendicular direction to the lead screw. (The test was performed with the actuator in the initial state.)

*6 The static allowable moment is the amount of static moment which can be applied to the actuator when it is stopped.

If the product is exposed to impact or repeated load, be sure to take adequate safety measures when using the product.

*7 The amount of particle generation changes according to the operating conditions and suction flow rate. Refer to the particle generation characteristics for details.

*8 Indicates the max. power during operation (including the driver) When selecting the power supply capacity, refer to the power supply capacity in the operation manual of each driver.

*9 Only when motor option "With lock" is selected

*10 For motor type T6, T7, and T8, the resolution will change depending on the driver type.

Weight

Series		11-LEFS25S□											
Stroke [mm]		50	100	150	200	250	300	350	400	450	500	550	600
Motor type	S2	2.00	2.14	2.28	2.44	2.56	2.69	2.84	2.99	3.12	3.24	3.40	3.54
	T6	2.04	2.18	2.32	2.48	2.60	2.73	2.88	3.03	3.16	3.28	3.44	3.58
Additional weight with lock [kg]		S2: 0.2/T6: 0.3											

Series		11-LEFS32S□															
Stroke [mm]		50	100	150	200	250	300	350	400	450	500	550	600	650	700	750	800
Motor type	S3	3.40	3.60	3.80	4.00	4.20	4.40	4.60	4.80	5.00	5.20	5.40	5.60	5.80	6.00	6.20	6.40
	T7	3.31	3.51	3.71	3.91	4.11	4.31	4.51	4.71	4.91	5.11	5.31	5.51	5.71	5.91	6.11	6.31
Additional weight with lock [kg]		S3: 0.4/T7: 0.5															

Series		11-LEFS40S□																	
Stroke [mm]		150	200	250	300	350	400	450	500	550	600	650	700	750	800	850	900	950	1000
Motor type	S4	5.82	6.10	6.38	6.65	6.95	7.25	7.51	7.80	8.07	8.25	8.63	8.90	9.20	9.45	9.76	10.05	10.32	10.60
	T8	5.91	6.19	6.47	6.74	7.04	7.34	7.60	7.89	8.16	8.34	8.72	8.99	9.29	9.54	9.85	10.14	10.41	10.69
Additional weight with lock [kg]		S4: 0.5/T8: 0.5																	

Slider Type Ball Screw Drive

Clean Room Specification

11-LEFS Series LEFS25, 32, 40

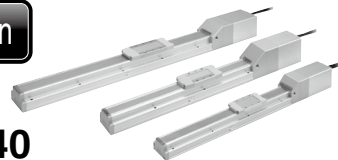

Refer to page 129 for model selection and page 939 for particle generation characteristics.



* For details, refer to page 1343 and onward.

LECY □ Series ▶ p. 953

How to Order

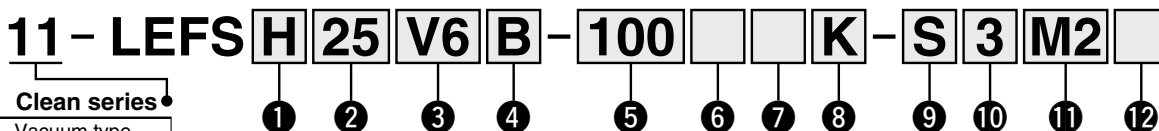

1 Accuracy

Nil	Basic type
H	High-precision type

2 Size

25
32
40

4 Lead [mm]

Symbol	11-LEFS25	11-LEFS32	11-LEFS40
A	12	16	20
B	6	8	10

5 Stroke [mm]*2

50 to 1000	50 to 1000
------------	------------

6 Motor option

Nil	Without option
B	With lock

7 Vacuum port*4, *5

Nil	Left
R	Right
D	Both left and right

3 Motor type

Symbol	Type	Output [W]	2 Size	1 Driver type	Compatible drivers
V6*1	AC servo motor (Absolute encoder)	100	25	M2	LECYM2-V5
V7		200	32	U2	LECYU2-V5
V8	AC servo motor (Absolute encoder)	400	40	M2	LECYM2-V7
				U2	LECYU2-V7
				M2	LECYM2-V8
				U2	LECYU2-V8

*1 For motor type V6, the compatible driver part number suffix is V5.

*2 For details, refer to the applicable stroke table below.

8 Positioning pin hole

Nil	Housing B bottom*6	
K	Body bottom 2 locations	

*6 Refer to the body mounting example on page 280 for the mounting method.

*4 Select "D" for the vacuum port for suction of 50 L/min (ANR) or more.

*5 Vacuum piping is only built in on the vacuum port side selected at the time of purchase. Note that after purchase, if suction is used on the port on the opposite side, the particle generation characteristics stated in the catalog may not apply. To make any changes after purchase, be sure to contact SMC.

9 Cable type*7, *8

Nil	Without cable
S	Standard cable
R	Robotic cable

*7 A motor cable and encoder cable are included with the product. (A lock cable is also included if motor option "B: With lock" is selected.)

*8 Standard cable entry direction is "(B) Counter axis side." (Refer to page 1134 for details.)

10 Actuator cable length [m]

Nil	Without cable
3	3
5	5
A	10
C	20

12 I/O cable length [m]*10

Nil	Without cable
H	Without cable (Connector only)
1	1.5

*10 When "Nil: Without driver" is selected for the driver type, only "Nil: Without cable" can be selected. Refer to page 1135 if an I/O cable is required. (Options are shown on page 1135.)

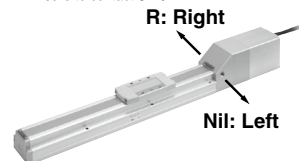

11 Driver type*9

	Compatible drivers	Power supply voltage [V]
Nil	Without driver	—
M2	LECYM2-V□	200 to 230
U2	LECYU2-V□	200 to 230

*9 When a driver type is selected, a cable is included. Select the cable type and cable length.

Applicable Stroke Table*3

Model	Stroke [mm]																				
	50	100	150	200	250	300	350	400	450	500	550	600	650	700	750	800	850	900	950	1000	
11-LEFS25	●	●	●	●	●	●	●	●	●	●	●	●	●	—	—	—	—	—	—	—	—
11-LEFS32	●	●	●	●	●	●	●	●	●	●	●	●	●	●	●	●	●	—	—	—	—
11-LEFS40	—	—	●	●	●	●	●	●	●	●	●	●	●	●	●	●	●	●	●	●	●

*3 Please contact SMC for non-standard strokes as they are produced as special orders.

Support Guide/11-LEFG Series

The support guide was designed to support workpieces with significant overhang. [p. 961](#)



Compatible Drivers

Driver type	MECHATROLINK-II type	MECHATROLINK-III type
Series	LECYM	LECYU
Applicable network	MECHATROLINK-II	MECHATROLINK-III
Control encoder	Absolute 20-bit encoder	
Communication device	USB communication, RS-422 communication	
Power supply voltage [V]	200 to 230 VAC (50/60 Hz)	
Reference page	1128	

Specifications

AC Servo Motor

Model		11-LEFS25□V6		11-LEFS32□V7		11-LEFS40□V8			
Actuator specifications	Stroke [mm] ^{*1}	50 to 800		50 to 1000		150 to 1200			
	Work load [kg] ^{*2}	Horizontal	20	20	40	45	50	60	
		Vertical	8	15	10	20	15	30	
	Max. speed [mm/s] ^{*3}	Stroke range	Up to 400	900	450	1000	500	1000	500
			401 to 500	720	360	1000	500	1000	500
			501 to 600	540	270	800	400	1000	500
			601 to 700	420	210	620	310	940	470
			701 to 800	330	160	500	250	760	380
			801 to 900	—	—	410	200	620	310
			901 to 1000	—	—	340	170	520	260
			1001 to 1100	—	—	—	—	440	220
	1101 to 1200	—	—	—	—	380	190		
	Max. acceleration/deceleration [mm/s ²]	20000 (Refer to pages 123 to 125 for limit according to work load and duty ratio.)							
	Positioning repeatability [mm]	Basic type	±0.02						
		High-precision type	±0.01						
Lost motion [mm] ^{*4}	Basic type	0.1 or less							
	High-precision type	0.05 or less							
Lead [mm]	12	6	16	8	20	10			
Impact/Vibration resistance [m/s ²] ^{*5}	50/20								
Actuation type	Ball screw (LEFS□), Ball screw + Belt (LEFS□ [Ⓡ])								
Guide type	Linear guide								
Static allowable moment ^{*6} [N·m]	Mep (Pitching)	27		46		110			
	Mey (Yawing)	27		46		110			
	Mer (Rolling)	52		101		207			
Operating temperature range [°C]	5 to 40								
Operating humidity range [%RH]	90 or less (No condensation)								
Cleanliness class ^{*7}	ISO Class 4 (ISO 14644-1) Class 10 (Fed.Std.209E)								
Grease	Ball screw /Linear guide portion Low particle generation grease								
Electric specifications	Motor output/Size	100 W/□40		200 W/□60		400 W/□60			
	Motor type	AC servo motor (200 VAC)							
	Encoder	Absolute 20-bit encoder (Resolution: 1048576 p/rev)							
	Power [W] ^{*8}	Max. power 445		Max. power 725		Max. power 1275			
Lock unit specifications	Type ^{*9}	Non-magnetizing lock							
	Holding force [N]	131	255	197	385	330	660		
	Power [W] at 20°C	5.5		6		6			
	Rated voltage [V]	24 VDC ^{+10%} / ₀							

- *1 Please contact SMC for non-standard strokes as they are produced as special orders.
 *2 For details, refer to the "Speed-Work Load Graph (Guide)" on page 130.
 *3 The allowable speed changes according to the stroke.
 *4 A reference value for correcting errors in reciprocal operation
 *5 Impact resistance: No malfunction occurred when the actuator was tested with a drop tester in both an axial direction and a perpendicular direction to the lead screw. (The test was performed with the actuator in the initial state.)
 Vibration resistance: No malfunction occurred in a test ranging between 45 to 2000 Hz. The test was performed in both an axial direction and a perpendicular direction to the lead screw. (The test was performed with the actuator in the initial state.)

- *6 The static allowable moment is the amount of static moment which can be applied to the actuator when it is stopped.
 If the product is exposed to impact or repeated load, be sure to take adequate safety measures when using the product.
 *7 The amount of particle generation changes according to the operating conditions and suction flow rate. Refer to the particle generation characteristics for details.
 *8 Indicates the max. power during operation (including the driver)
 When selecting the power supply capacity, refer to the power supply capacity in the operation manual of each driver.
 *9 Only when motor option "With lock" is selected

Weight

Series	11-LEFS25□V6															
Stroke [mm]	50	100	150	200	250	300	350	400	450	500	550	600	650	700	750	800
Product weight [kg]	2.06	2.20	2.34	2.50	2.62	2.75	2.90	3.05	3.18	3.30	3.46	3.60	3.74	3.88	4.02	4.20
Additional weight with lock [kg]	0.3															

Series	11-LEFS32□V7																			
Stroke [mm]	50	100	150	200	250	300	350	400	450	500	550	600	650	700	750	800	850	900	950	1000
Product weight [kg]	3.40	3.60	3.80	4.00	4.20	4.40	4.60	4.80	5.00	5.20	5.40	5.60	5.80	6.00	6.20	6.40	6.60	6.80	7.00	7.20
Additional weight with lock [kg]	0.7																			

Series	11-LEFS40□V8																			
Stroke [mm]	150	200	250	300	350	400	450	500	550	600	650	700	750	800	850	900	950	1000	1100	1200
Product weight [kg]	5.92	6.20	6.48	6.75	7.05	7.35	7.61	7.90	8.17	8.35	8.73	9.00	9.30	9.55	9.86	10.15	10.42	10.70	11.26	11.82
Additional weight with lock [kg]	0.7																			

11-LEFS Series

AC Servo Motor

Clean Room Specification

Dimensions: Ball Screw Drive

11-LEFS25

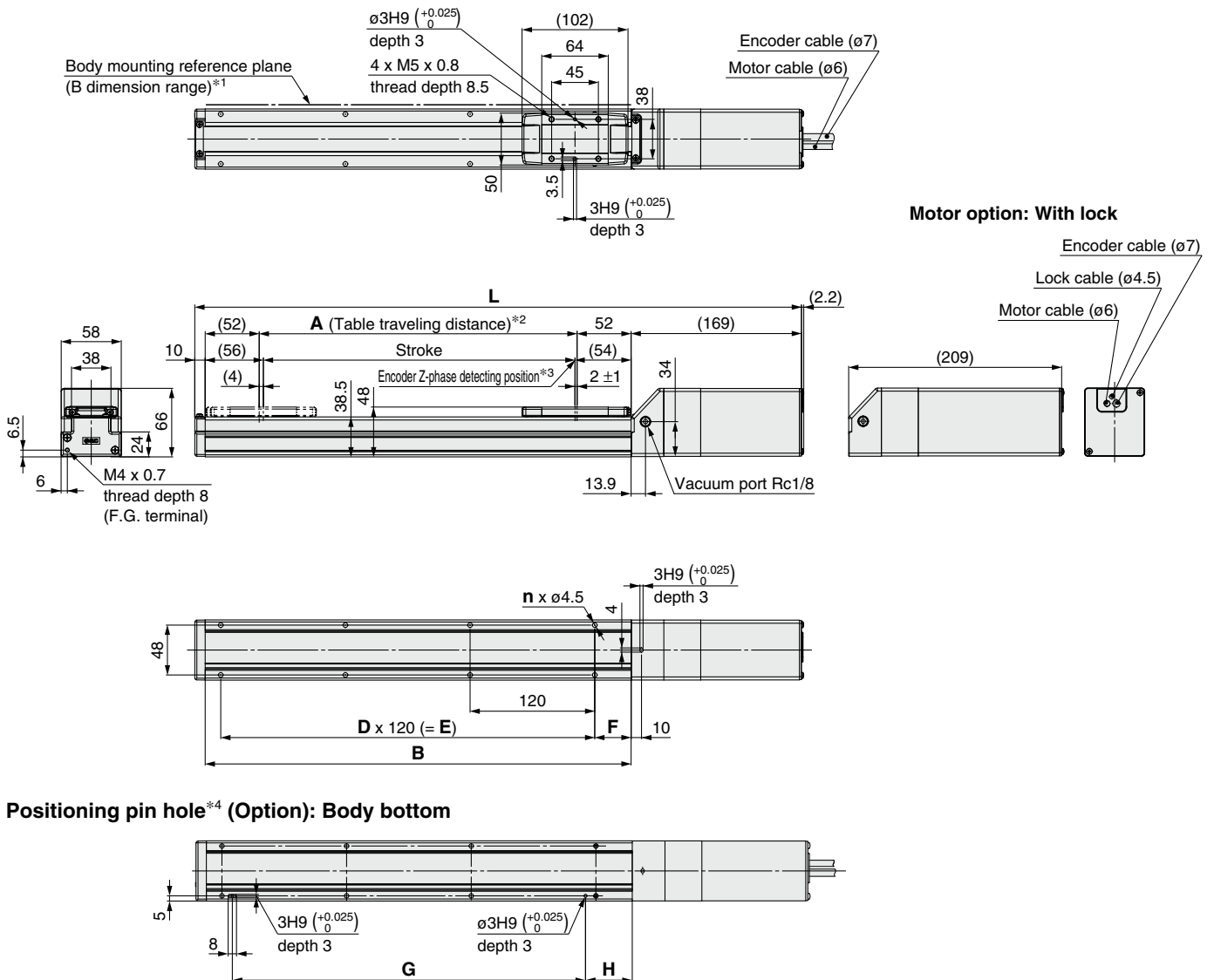

Positioning pin hole^{*4} (Option): Body bottom

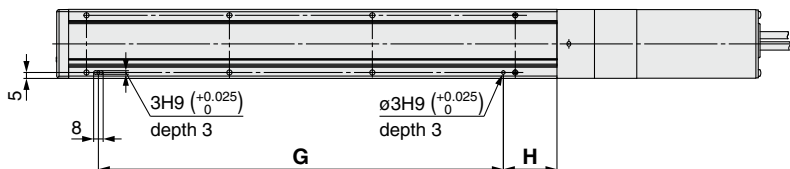

- *1 When mounting the actuator using the body mounting reference plane, set the height of the opposite surface or pin to be 3 mm or more because of round chamfering. (Recommended height: 5 mm)
In addition, be aware that surfaces other than the body mounting reference plane (B dimension range) may slightly protrude from the body mounting reference plane. Be sure to provide a clearance of 1 mm or more to avoid interference with workpieces, facilities, etc.
- *2 This is the distance within which the table can move when it returns to origin.
Make sure that workpieces mounted on the table do not interfere with other workpieces or the facilities around the table.
- *3 The Z-phase first detecting position from the stroke end of the motor side
- *4 When using the body bottom positioning pin holes, do not simultaneously use the housing B bottom pin hole.

Dimensions

[mm]

Model	L		A	B	n	D	E	F	G	H
	Without lock	With lock								
11-LEFS□25□□-50□	339	379	56	160	4	—	—	20	100	30
11-LEFS□25□□-100□	389	429	106	210	4	—	—		100	45
11-LEFS□25□□-150□	439	479	156	260	4	—	—		100	45
11-LEFS□25□□-200□	489	529	206	310	6	2	240		220	45
11-LEFS□25□□-250□	539	579	256	360	6	2	240		220	45
11-LEFS□25□□-300□	589	629	306	410	8	3	360		340	45
11-LEFS□25□□-350□	639	679	356	460	8	3	360		340	45
11-LEFS□25□□-400□	689	729	406	510	8	3	360		340	45
11-LEFS□25□□-450□	739	779	456	560	10	4	480		460	45
11-LEFS□25□□-500□	789	829	506	610	10	4	480		460	45
11-LEFS□25□□-550□	839	879	556	660	12	5	600		580	45
11-LEFS□25□□-600□	889	929	606	710	12	5	600		580	45

Dimensions: Ball Screw Drive

11-LEFS32

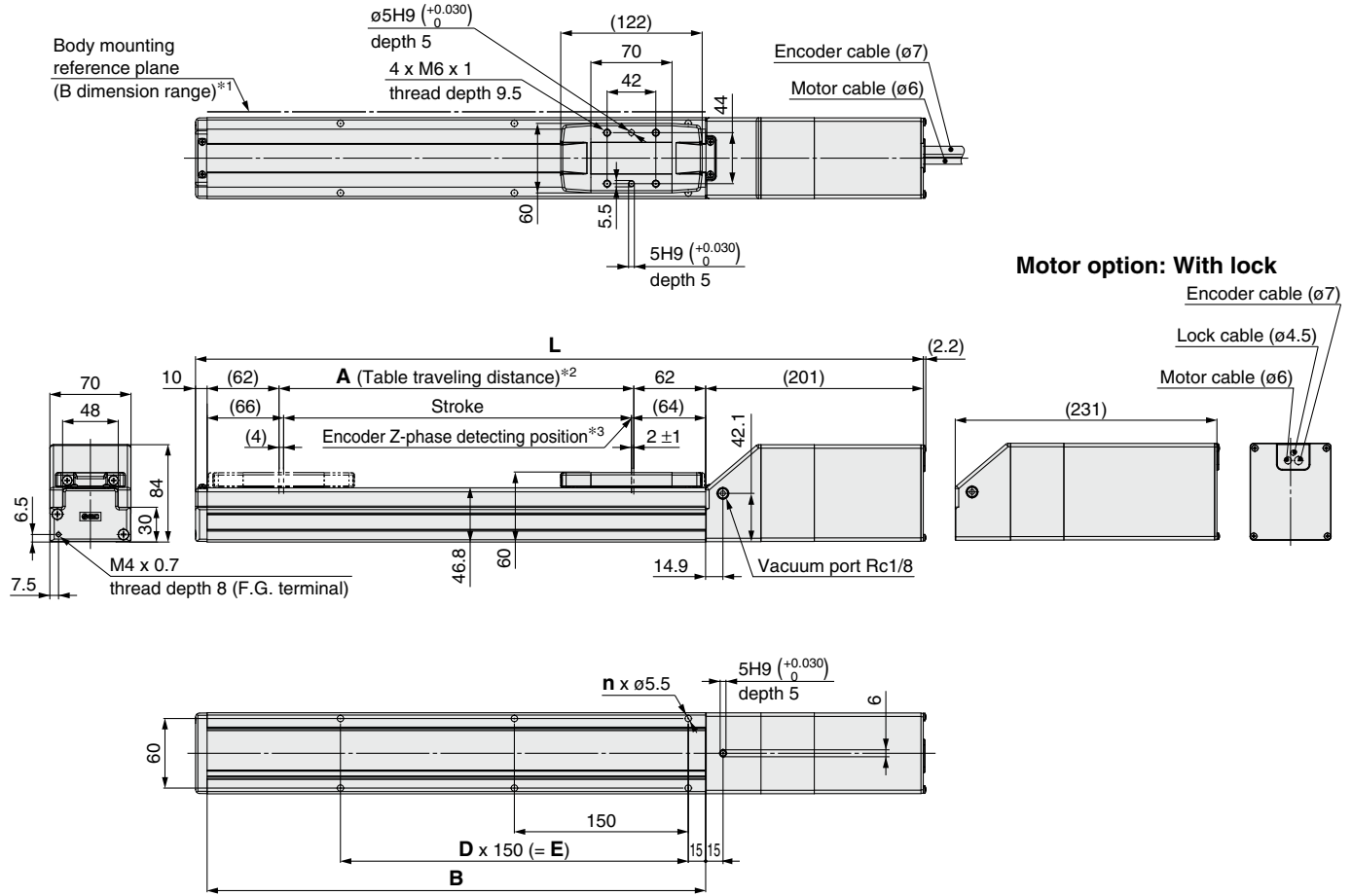

Positioning pin hole*4 (Option): Body bottom

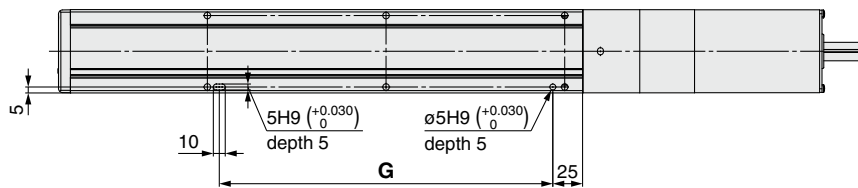

*1 When mounting the actuator using the body mounting reference plane, set the height of the opposite surface or pin to be 3 mm or more because of round chamfering. (Recommended height: 5 mm)

In addition, be aware that surfaces other than the body mounting reference plane (B dimension range) may slightly protrude from the body mounting reference plane. Be sure to provide a clearance of 1 mm or more to avoid interference with workpieces, facilities, etc.

*2 This is the distance within which the table can move when it returns to origin. Make sure that workpieces mounted on the table do not interfere with other workpieces or the facilities around the table.

*3 The Z-phase first detecting position from the stroke end of the motor side

*4 When using the body bottom positioning pin holes, do not simultaneously use the housing B bottom pin hole.

Dimensions

[mm]

Model	L		A	B	n	D	E	G
	Without lock	With lock						
11-LEFS□32□□-50□	391	421	56	180	4	—	—	130
11-LEFS□32□□-100□	441	471	106	230	4	—	—	130
11-LEFS□32□□-150□	491	521	156	280	4	—	—	130
11-LEFS□32□□-200□	541	571	206	330	6	2	300	280
11-LEFS□32□□-250□	591	621	256	380	6	2	300	280
11-LEFS□32□□-300□	641	671	306	430	6	2	300	280
11-LEFS□32□□-350□	691	721	356	480	8	3	450	430
11-LEFS□32□□-400□	741	771	406	530	8	3	450	430
11-LEFS□32□□-450□	791	821	456	580	8	3	450	430
11-LEFS□32□□-500□	841	871	506	630	10	4	600	580
11-LEFS□32□□-550□	891	921	556	680	10	4	600	580
11-LEFS□32□□-600□	941	971	606	730	10	4	600	580
11-LEFS□32□□-650□	991	1021	656	780	12	5	750	730
11-LEFS□32□□-700□	1041	1071	706	830	12	5	750	730
11-LEFS□32□□-750□	1091	1121	756	880	12	5	750	730
11-LEFS□32□□-800□	1141	1171	806	930	14	6	900	880

11-LEFS Series

AC Servo Motor

Clean Room Specification

Dimensions: Ball Screw Drive

11-LEFS40

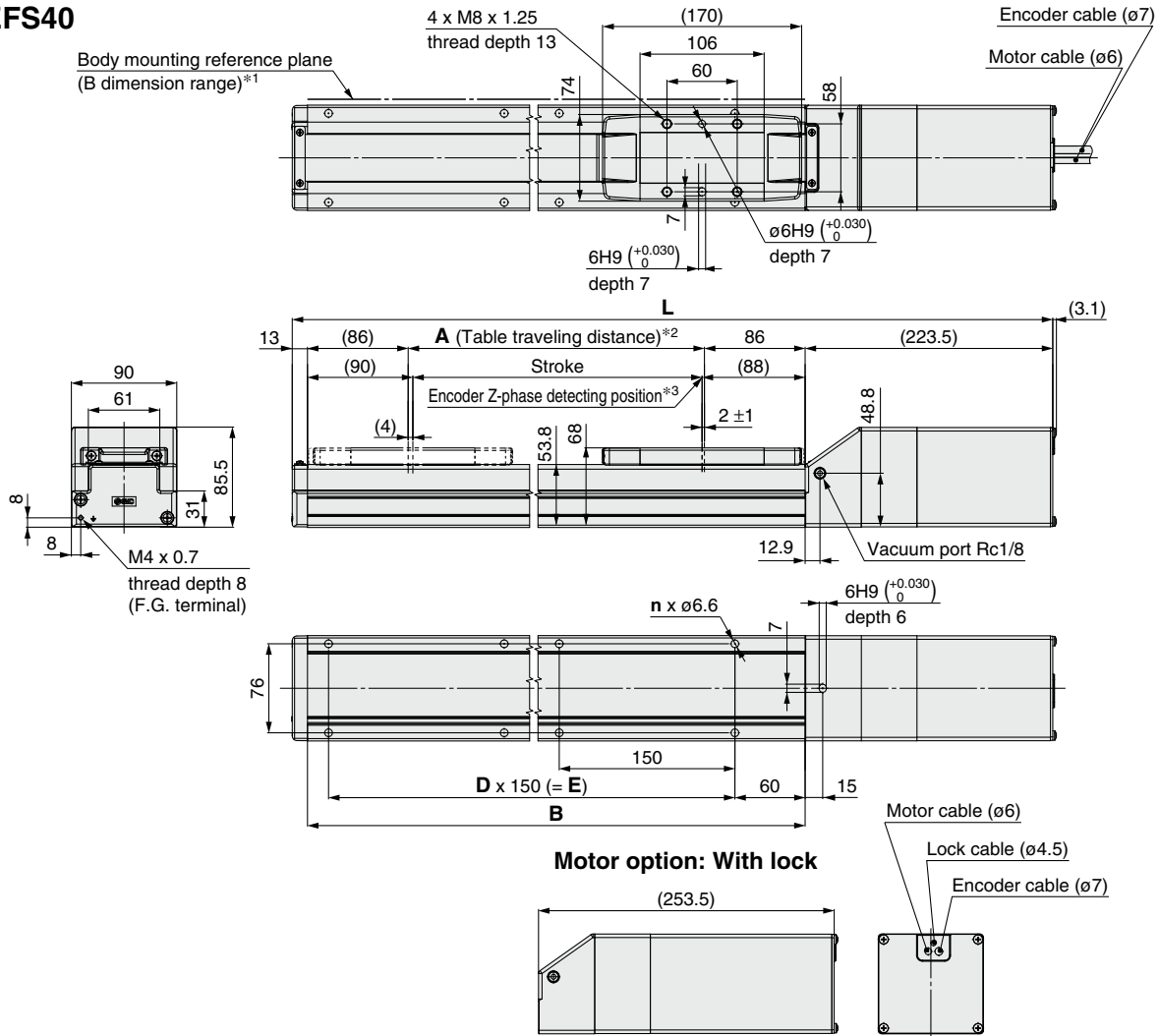

Positioning pin hole*4 (Option): Body bottom

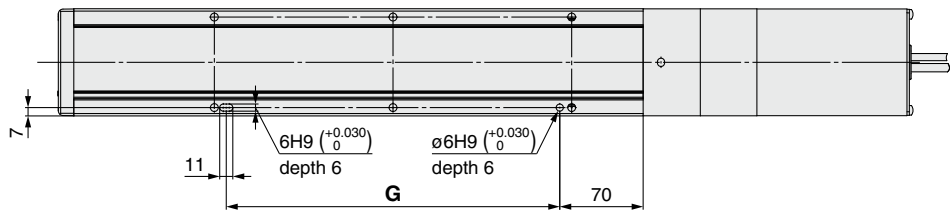

*1 When mounting the actuator using the body mounting reference plane, set the height of the opposite surface or pin to be 3 mm or more because of round chamfering.
(Recommended height: 5 mm)

In addition, be aware that surfaces other than the body mounting reference plane (B dimension range) may slightly protrude from the body mounting reference plane. Be sure to provide a clearance of 1 mm or more to avoid interference with workpieces, facilities, etc.

*2 This is the distance within which the table can move when it returns to origin. Make sure that workpieces mounted on the table do not interfere with other workpieces or the facilities around the table.

*3 The Z-phase first detecting position from the stroke end of the motor side

*4 When using the body bottom positioning pin holes, do not simultaneously use the housing B bottom pin hole.

Dimensions

Model	L		A	B	n	D	E	G
	Without lock	With lock						
11-LEFS□40□□-150□	564.5	594.5	156	328	4	—	150	130
11-LEFS□40□□-200□	614.5	644.5	206	378	6	2	300	280
11-LEFS□40□□-250□	664.5	694.5	256	428	6	2	300	280
11-LEFS□40□□-300□	714.5	744.5	306	478	6	2	300	280
11-LEFS□40□□-350□	764.5	794.5	356	528	8	3	450	430
11-LEFS□40□□-400□	814.5	844.5	406	578	8	3	450	430
11-LEFS□40□□-450□	864.5	894.5	456	628	8	3	450	430
11-LEFS□40□□-500□	914.5	944.5	506	678	10	4	600	580
11-LEFS□40□□-550□	964.5	994.5	556	728	10	4	600	580
11-LEFS□40□□-600□	1014.5	1044.5	606	778	10	4	600	580
11-LEFS□40□□-650□	1064.5	1094.5	656	828	12	5	750	730
11-LEFS□40□□-700□	1114.5	1144.5	706	878	12	5	750	730
11-LEFS□40□□-750□	1164.5	1194.5	756	928	12	5	750	730
11-LEFS□40□□-800□	1214.5	1244.5	806	978	14	6	900	880
11-LEFS□40□□-850□	1264.5	1294.5	856	1028	14	6	900	880
11-LEFS□40□□-900□	1314.5	1344.5	906	1078	14	6	900	880
11-LEFS□40□□-950□	1364.5	1394.5	956	1128	16	7	1050	1030
11-LEFS□40□□-1000□	1414.5	1444.5	1006	1178	16	7	1050	1030

Support Guide for Ball Screw Drive Actuator

11-LEFG Series 11-LEFG16, 25, 32, 40

RoHS

Application example

The support guide was designed to support workpieces with significant overhang.

- As the dimensions are the same as the 11-LEF series body, installation is simple and contributes to a reduction in installation and assembly labor.
- The standard-equipped seal bands prevent grease from splashing and external foreign matter from entering.

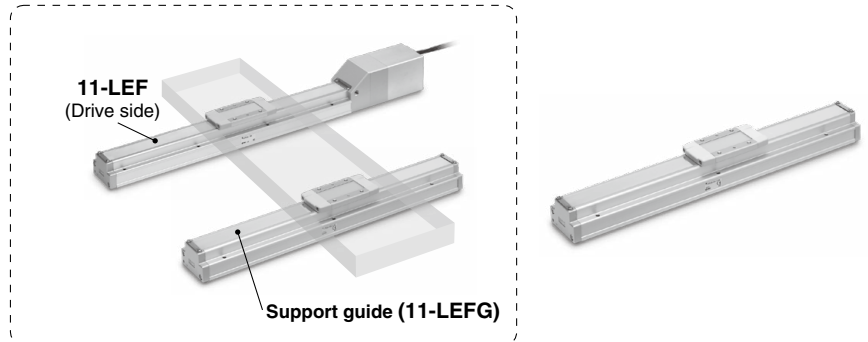

How to Order

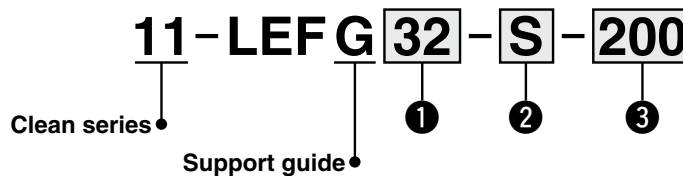

① Size

16
25
32
40

② Type of mounting pitch

Symbol	11-LEFG16	11-LEFG25	11-LEFG32	11-LEFG40	Applicable model	
S	●	●	●	●	For ball screw drive	Step motor 24 VDC (Incremental), Servo motor 24 VDC, AC servo motor

③ Stroke [mm]

50	50
to	to
1000	1000

Applicable Stroke Table For Ball Screw Drive: S

Model \ Stroke [mm]	50	100	150	200	250	300	350	400	450	500	550	600	650	700	750	800	850	900	950	1000
11-LEFG16-S	●	●	●	●	●	●	●	●	●	●	—	—	—	—	—	—	—	—	—	—
11-LEFG25-S	●	●	●	●	●	●	●	●	●	●	●	●	—	—	—	—	—	—	—	—
11-LEFG32-S	●	●	●	●	●	●	●	●	●	●	●	●	●	●	●	●	—	—	—	—
11-LEFG40-S	—	—	●	●	●	●	●	●	●	●	●	●	●	●	●	●	●	●	●	●

Weight

For Ball Screw Drive: S

Model \ Stroke [mm]	50	100	150	200	250	300	350	400	450	500	550	600	650	700	750	800	850	900	950	1000
11-LEFG16-S	0.25	0.31	0.37	0.43	0.49	0.55	0.61	0.67	0.73	0.79	—	—	—	—	—	—	—	—	—	—
11-LEFG25-S	0.56	0.67	0.78	0.89	1.00	1.11	1.22	1.33	1.44	1.55	1.66	1.77	—	—	—	—	—	—	—	—
11-LEFG32-S	0.92	1.08	1.23	1.4	1.56	1.72	1.88	2.04	2.20	2.36	2.52	2.88	2.84	3.00	3.16	3.22	—	—	—	—
11-LEFG40-S	—	—	2.07	2.29	2.51	2.72	2.94	3.15	3.37	3.58	3.80	4.01	4.23	4.44	4.66	4.87	5.09	5.30	5.52	5.73

Dimensions: For Ball Screw Drive

11-LEFG16-S

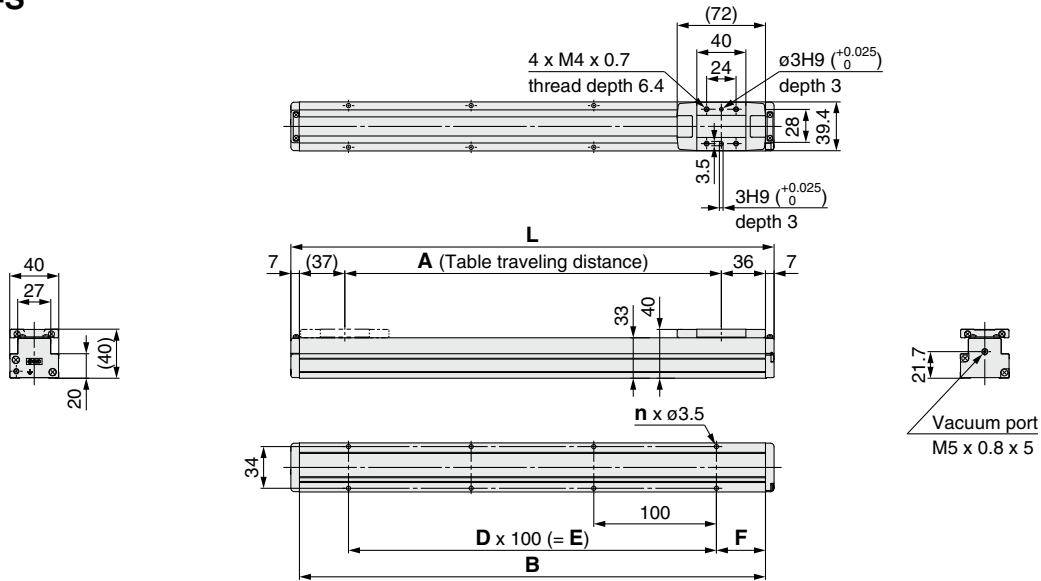

Dimensions

Model	L	A	B	n	D	E	F
11-LEFG16-S-50	144	57	130	4	—	—	15
11-LEFG16-S-100	194	107	180				40
11-LEFG16-S-150	244	157	230				
11-LEFG16-S-200	294	207	280				
11-LEFG16-S-250	344	257	330				
11-LEFG16-S-300	394	307	380				
11-LEFG16-S-350	444	357	430	8	3	300	40
11-LEFG16-S-400	494	407	480	10	4	400	
11-LEFG16-S-450	544	457	530	12	5	500	

11-LEFG25-S

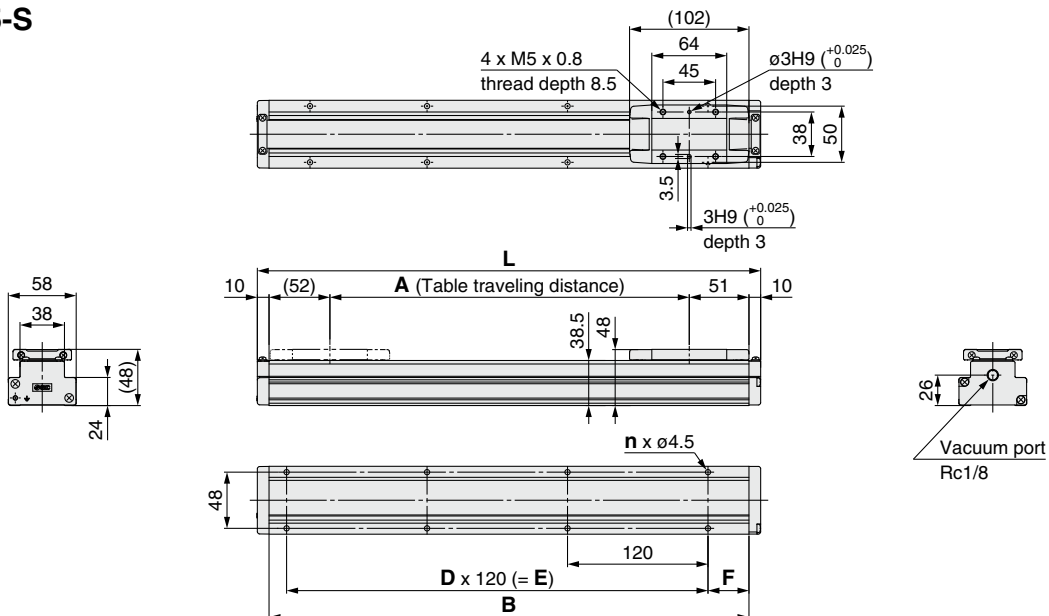

Dimensions

Model	L	A	B	n	D	E	F
11-LEFG25-S-50	180	57	160	4	—	—	20
11-LEFG25-S-100	230	107	210				35
11-LEFG25-S-150	280	157	260				
11-LEFG25-S-200	330	207	310				
11-LEFG25-S-250	380	257	360				
11-LEFG25-S-300	430	307	410	8	3	360	
11-LEFG25-S-350	480	357	460	8	3	360	35
11-LEFG25-S-400	530	407	510				

Dimensions

Model	L	A	B	n	D	E	F
11-LEFG25-S-450	580	457	560	10	4	480	35
11-LEFG25-S-500	630	507	610	12	5	600	
11-LEFG25-S-550	680	557	660				
11-LEFG25-S-600	730	607	710	12	5	600	

11-LEFG Series

Dimensions: For Ball Screw Drive

11-LEFG32-S

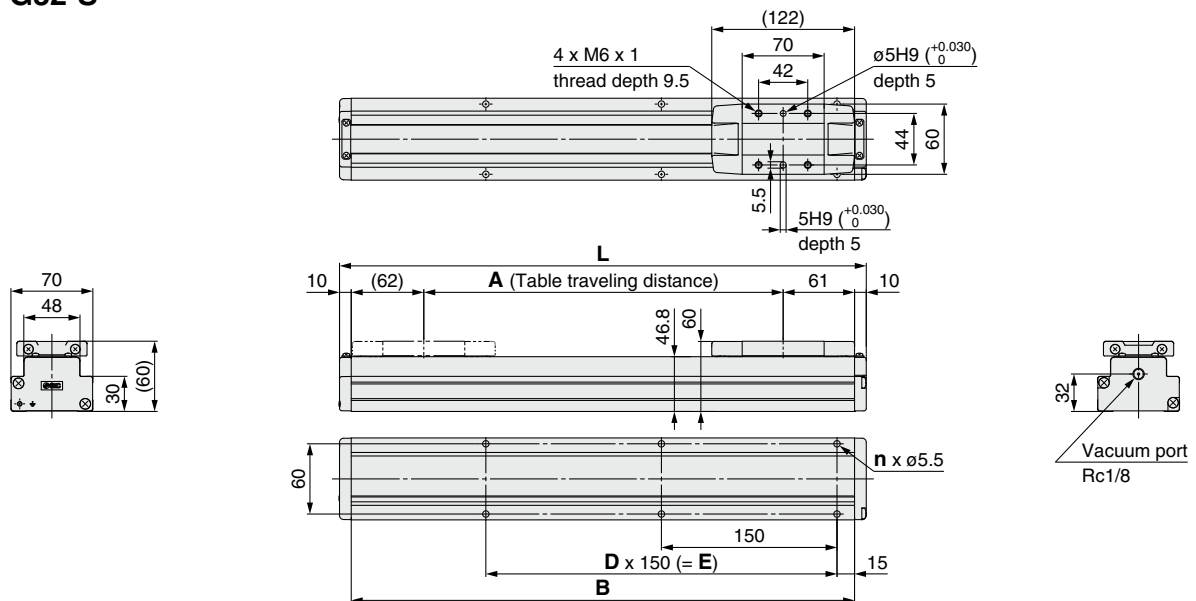

Dimensions

Model	L	A	B	n	D	E
11-LEFG32-S-50	200	57	180	4	—	—
11-LEFG32-S-100	250	107	230			
11-LEFG32-S-150	300	157	280			
11-LEFG32-S-200	350	207	330	6	2	300
11-LEFG32-S-250	400	257	380			
11-LEFG32-S-300	450	307	430			
11-LEFG32-S-350	500	357	480	8	3	450
11-LEFG32-S-400	550	407	530			
11-LEFG32-S-450	600	457	580			

Dimensions

Model	L	A	B	n	D	E
11-LEFG32-S-500	650	507	630	10	4	600
11-LEFG32-S-550	700	557	680			
11-LEFG32-S-600	750	607	730			
11-LEFG32-S-650	800	657	780	12	5	750
11-LEFG32-S-700	850	707	830			
11-LEFG32-S-750	900	757	880			
11-LEFG32-S-800	950	807	930	14	6	900

Dimensions: For Ball Screw Drive

11-LEFG40-S

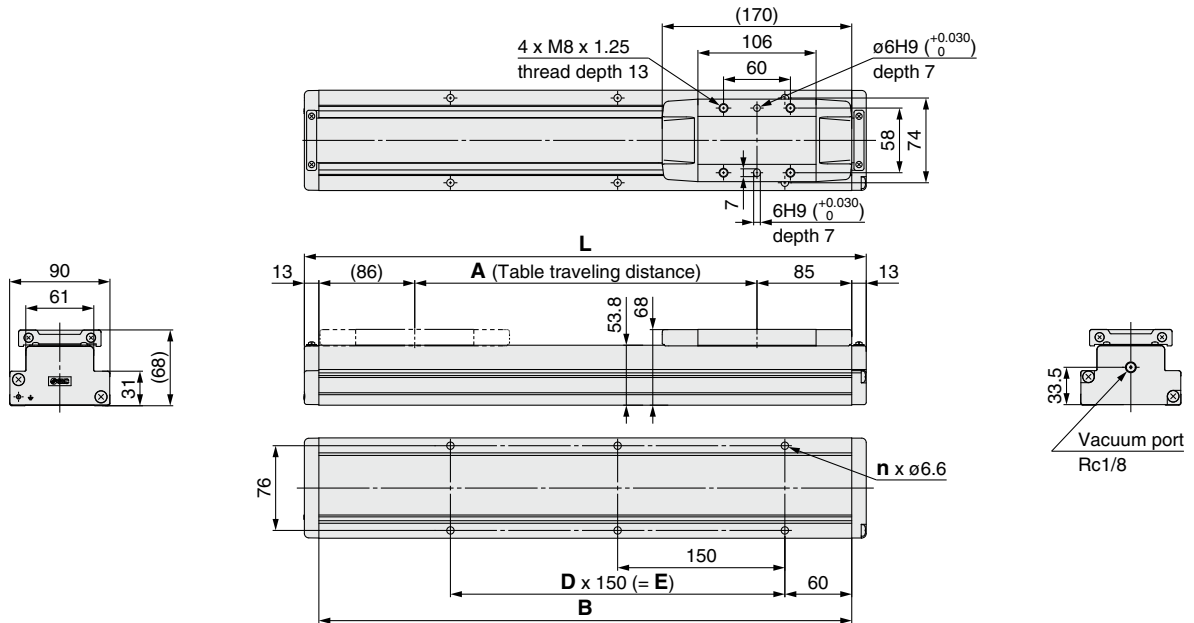

Dimensions

Model	L	A	B	n	D	E
11-LEFG40-S-150	354	157	328	4	—	150
11-LEFG40-S-200	404	207	378	6	2	300
11-LEFG40-S-250	454	257	428			
11-LEFG40-S-300	504	307	478	8	3	450
11-LEFG40-S-350	554	357	528			
11-LEFG40-S-400	604	407	578			
11-LEFG40-S-450	654	457	628	10	4	600
11-LEFG40-S-500	704	507	678			
11-LEFG40-S-550	754	557	728			
11-LEFG40-S-600	804	607	778			

Dimensions

Model	L	A	B	n	D	E
11-LEFG40-S-650	854	657	828	12	5	750
11-LEFG40-S-700	904	707	878			
11-LEFG40-S-750	954	757	928	14	6	900
11-LEFG40-S-800	1004	807	978			
11-LEFG40-S-850	1054	857	1028			
11-LEFG40-S-900	1104	907	1078	16	7	1050
11-LEFG40-S-950	1154	957	1128			
11-LEFG40-S-1000	1204	1007	1178			

Particle Generation Characteristics

11-LEJS Series ▶ p. 967

Particle Generation Measuring Method

The particle generation data for the 11-LEJS series are measured in the following test method.

Test Method (Example)

Operate the specimen that is placed in an ISO Class 5 equivalent clean bench, and measure the changes of the particle concentration over time until the number of cycles reaches the specified point.

Measuring Conditions

Measuring instrument	Description	Laser dust monitor (Automatic particle counter using the light scattering method)
	Minimum measurable particle diameter	0.1 μm
	Suction flow rate	28.3 L/min (ANR)
Setting conditions	Sampling time	5 min
	Interval time	55 min
	Sampling air flow	141.5 L (ANR)

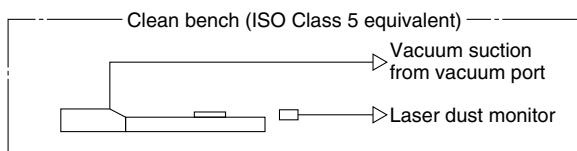

Test Conditions

Size	Speed [mm/s]	Model	Workpiece mass [kg]	Acceleration [mm/s ²]	Duty ratio [%]
40	1200	11-LEJS40□A-200	4	13000	100
	600	11-LEJS40□B-200		10000	
63	1200	11-LEJS63□A-300		13000	
	600	11-LEJS63□B-300		10000	

* Mounting position: Horizontal

Evaluation Method

To obtain the measured values of particle concentration, the accumulated value*¹ of particles captured every 5 minutes, by the laser dust monitor, is converted into the particle concentration in every 1 m³.

When determining particle generation grades, the 95% upper confidence limit of the average particle concentration (average value), when each specimen is operated at a specified number of cycles*² is considered.

The plots in the graphs indicate the 95% upper confidence limit of the average particle concentration of particles with a diameter within the horizontal axis range.

*¹ Sampling air flow rate: Number of particles contained in 141.5 L (ANR) of air

*² Actuator: 1 million cycles

* The particle generation characteristics (page 966) provide a guide for selection but is not guaranteed.

Particle Generation Characteristics

11-LEJS40/Ball Screw Drive

Speed 600 mm/s

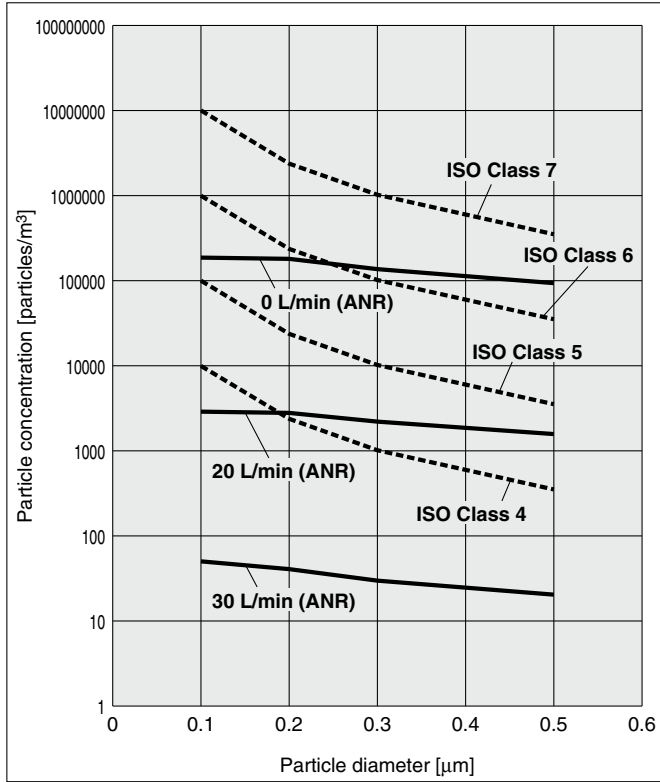

Speed 1200 mm/s

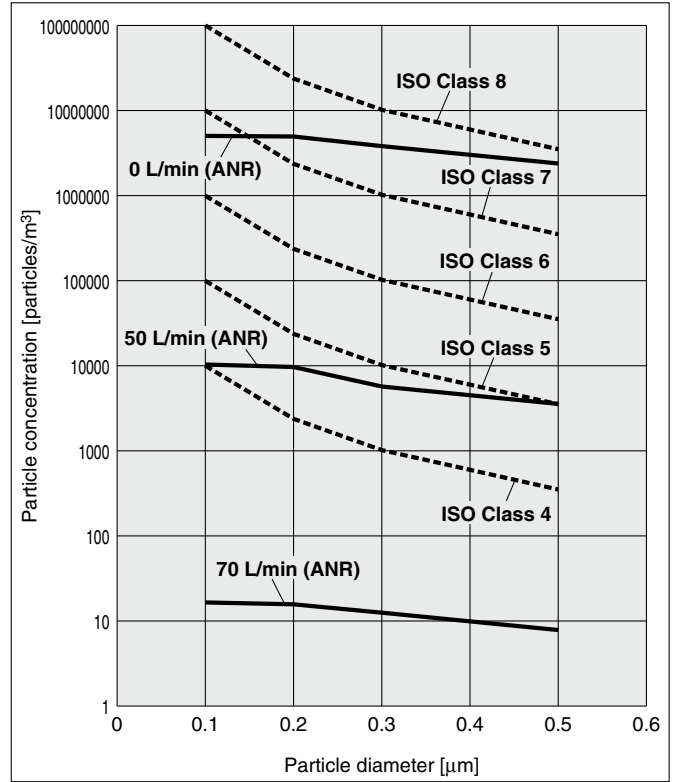

11-LEJS63/Ball Screw Drive

Speed 600 mm/s

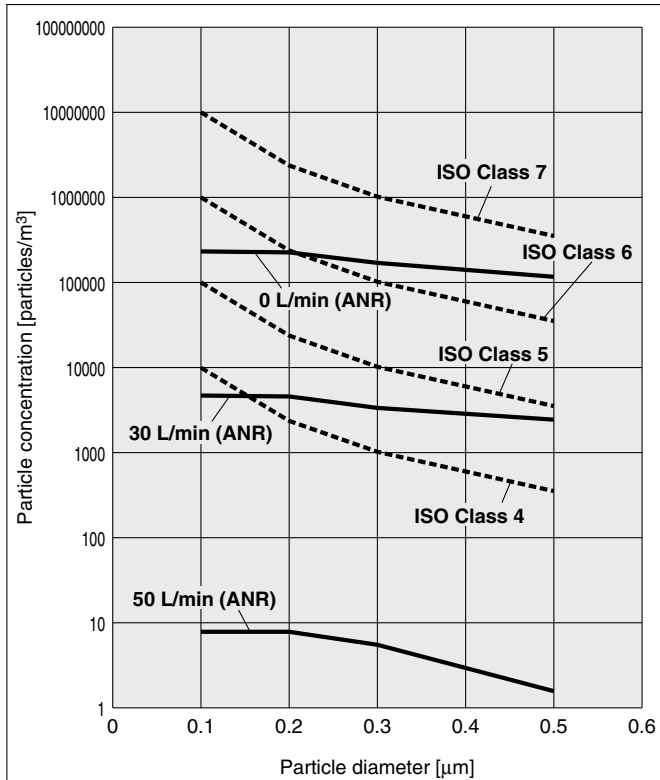

Speed 1200 mm/s

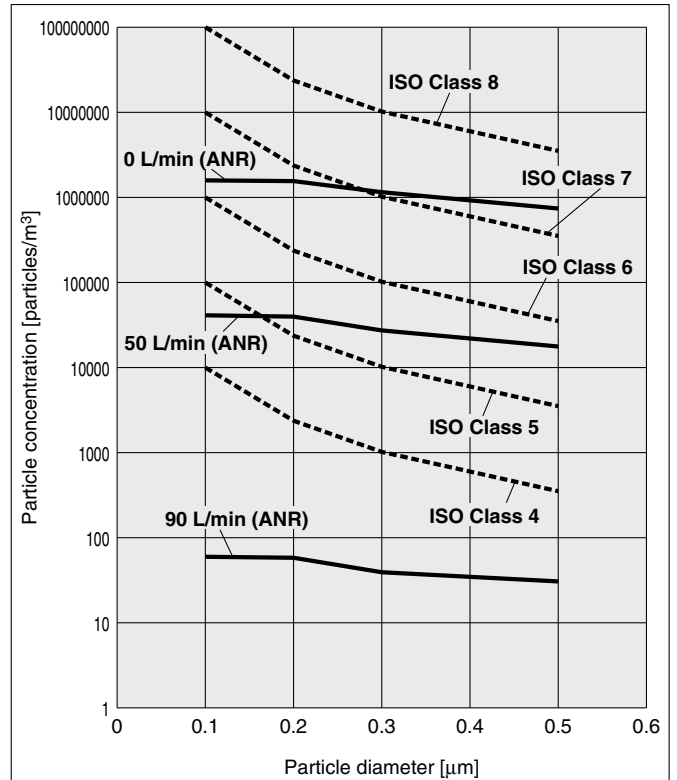

High Rigidity Slider Type Ball Screw Drive

Clean Room Specification

11-LEJS Series LEJS40, 63

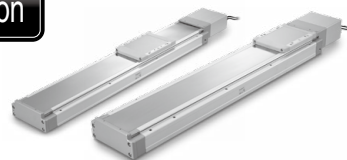

Refer to page 289 for model selection and page 965 for particle generation characteristics.



* For details, refer to page 1343 and onward.

LECY □ Series ▶ p. 969

How to Order

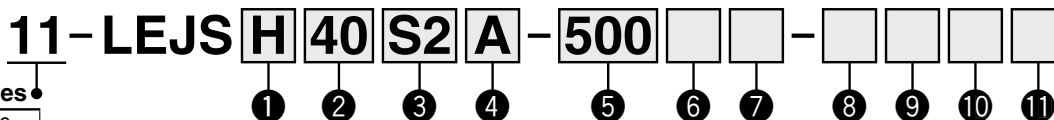

① Accuracy

Nil	Basic type
H	High-precision type

② Size

40
63

③ Motor type

Symbol	Type	Output [W]	② Size	⑩ Driver type	Compatible drivers
S2 ^{*1}	AC servo motor (Incremental encoder)	100	40	A1/A2	LECSA□-S1
		200	63	A1/A2	LECSA□-S3
T6 ^{*2}	AC servo motor (Absolute encoder)	100	40	B2	LECSB2-T5
				C2	LECS2-T5
				S2	LECSS2-T5
T7	AC servo motor (Absolute encoder)	200	63	B2	LECSB2-T7
				C2	LECS2-T7
				S2	LECSS2-T7

*1 For motor type S2, the compatible driver part number suffix is S1.

*2 For motor type T6, the compatible driver part number is LECS□2-T5.

④ Lead [mm]

Symbol	LEJS40	LEJS63
A	16	20
B	8	10

⑤ Stroke [mm]^{*3}

200
to
1500

*3 Refer to the applicable stroke table for details.

⑨ Cable length [m]^{*7, *9}

Nil	Without cable
2	2 m
5	5 m
A	10 m

*9 The length of the motor, encoder, and lock cables are the same.

⑥ Motor option

Nil	Without option
B	With lock

⑦ Vacuum port^{*5, *6}

Nil	Left
R	Right
D	Both left and right

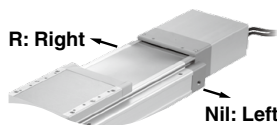

*5 Select "D" for the vacuum port for suction of 50 L/min (ANR) or more.

*6 Vacuum piping is only built in on the vacuum port side selected at the time of purchase. Note that after purchase, if suction is used on the port on the opposite side, the particle generation characteristics stated in the catalog may not apply. To make any changes after purchase, be sure to contact SMC.

⑧ Cable type^{*7, *8}

Nil	Without cable
S	Standard cable
R	Robotic cable

*7 A motor cable and encoder cable are included with the product. (A lock cable is also included if motor option "B: With lock" is selected.)

*8 Standard cable entry direction is "(A) Axis side."

⑩ Driver type^{*10}

Nil	Without driver	Power supply voltage [V]
A1	LECSA1-S□	100 to 120
A2	LECSA2-S□	200 to 230
B2	LECSB2-T□	200 to 240
C2	LECS2-T□	200 to 230
S2	LECSS2-T□	200 to 240

*10 When a driver type is selected, a cable is included. Select the cable type and cable length.

Example) S2S2: Standard cable (2 m) + Driver (LECSS2)
S2: Standard cable (2 m)
Nil: Without cable and driver

⑪ I/O cable length [m]^{*11}

Nil	Without cable
H	Without cable (Connector only)
1	1.5

*11 When "Nil: Without driver" is selected for the driver type, only "Nil: Without cable" can be selected.

Refer to page 1124 if an I/O cable is required. (Options are shown on page 1124.)

Applicable Stroke Table^{*4}

Model	Stroke [mm]											
	200	300	400	500	600	700	800	900	1000	1200	1500	
11-LEJS40	●	●	●	●	●	●	●	●	●	●	●	—
11-LEJS63	—	●	●	●	●	●	●	●	●	●	●	●

*4 Please contact SMC for non-standard strokes as they are produced as special orders.

For auto switches, refer to pages 332 to 335.

Compatible Drivers

Driver type	Pulse input type/ Positioning type	Pulse input type	CC-Link direct input type	SSCNET III/H type
Series	LECSA	LECSB-T	LECS2-T	LECSS-T
Number of point tables	Up to 7	Up to 255	Up to 255 (2 stations occupied)	—
Pulse input	○	○	—	—
Applicable network	—	—	CC-Link	SSCNET III/H
Control encoder	Incremental 17-bit encoder	Absolute 22-bit encoder	Absolute 18-bit encoder	Absolute 22-bit encoder
Communication function	USB communication	USB communication, RS422 communication	USB communication, RS422 communication	USB communication
Power supply voltage [V]	100 to 120 VAC (50/60 Hz) 200 to 230 VAC (50/60 Hz)	200 to 240 VAC (50/60 Hz)	200 to 230 VAC (50/60 Hz)	200 to 240 VAC (50/60 Hz)
Reference page	1109			

Specifications

11-LEJS40, 63 AC Servo Motor

Model		11-LEJS40S2/T6		11-LEJS63S3/T7			
Actuator specifications	Stroke [mm]*1	200, 300, 400, 500, 600, 700, 800 900, 1000, 1200		300, 400, 500, 600, 700, 800, 900 1000, 1200, 1500			
	Work load [kg]*2	Horizontal	30	55	45	85	
		Vertical	5	10	10	20	
	Speed*3 [mm/s]	Stroke range	Up to 500	1200	600	1200	600
			501 to 600	1050	520	1200	600
			601 to 700	780	390	1200	600
			701 to 800	600	300	930	460
			801 to 900	480	240	740	370
			901 to 1000	390	190	600	300
			1001 to 1100	320	160	500	250
			1101 to 1200	270	130	420	210
			1201 to 1300	—	—	360	180
			1301 to 1400	—	—	310	150
	1401 to 1500	—	—	270	130		
	Max. acceleration/deceleration [mm/s ²]	20000 (Refer to pages 293 and 294 for limit according to work load and duty ratio.)					
Positioning repeatability [mm]	Basic type	±0.02					
	High-precision type	±0.01					
Lost motion [mm]*4	Basic type	0.1 or less					
	High-precision type	0.05 or less					
Lead [mm]	16	8	20	10			
Impact/Vibration resistance [m/s ²]*5	50/20						
Actuation type	Ball screw						
Guide type	Linear guide						
Grease	Ball screw/Linear guide portion Low particle generation grease						
Cleanliness class*6	ISO Class 4 (ISO 14644-1)						
Allowable external force [N]	20						
Operating temperature range [°C]	5 to 40						
Operating humidity range [%RH]	90 or less (No condensation)						
Regeneration option	May be required depending on speed and work load (Refer to page 290.)						
Motor output [W]/Size [mm]	100□40		200□60				
Motor type	AC servo motor (100/200 VAC)						
Encoder*9	Motor type S2, S3: Incremental 17-bit encoder (Resolution: 131072 p/rev) Motor type T6, T7: Absolute 22-bit encoder (Resolution: 4194304 p/rev) (For LECSB-T□, LECS-S-T□) Motor type T6, T7: Absolute 18-bit encoder (Resolution: 262144 p/rev) (For LECS-C-T□)						
Power [W]*7	Max. power 445		Max. power 725				
Type*8	Non-magnetizing lock						
Holding force [N]	101	203	330	660			
Power [W] at 20°C	6.3		7.9				
Rated voltage [V]	24 VDC ⁰ / _{-10%}						

*1 Please contact SMC for non-standard strokes as they are produced as special orders.

*2 For details, refer to the "Speed-Work Load Graph (Guide)" on page 290.

*3 The allowable speed changes according to the stroke.

*4 A reference value for correcting errors in reciprocal operation

*5 Impact resistance: No malfunction occurred when the actuator was tested with a drop tester in both an axial direction and a perpendicular direction to the lead screw. (The test was performed with the actuator in the initial state.)

Vibration resistance: No malfunction occurred in a test ranging between 45 to 2000 Hz. The test was performed in both an axial direction and a perpendicular direction to the lead screw. (The test was performed with the actuator in the initial state.)

*6 The amount of particle generation changes according to the operating conditions and suction flow rate. Refer to the particle generation characteristics for details.

*7 Indicates the max. power during operation (including the driver)

When selecting the power supply capacity, refer to the power supply capacity in the operation manual of each driver.

*8 Only when motor option "With lock" is selected

*9 The resolution will change depending on the driver type.

* Sensor magnet position is located in the table center.

For detailed dimensions, refer to the "Auto Switch Mounting Position" on page 332.

* Do not allow collisions at either end of the table traveling distance. Additionally, when running the positioning operation, do not set within 2 mm of both ends.

* For the manufacture of intermediate strokes, please contact SMC.
(11-LEJS40/Manufacturable stroke range: 200 to 1200 mm, 11-LEJS63/Manufacturable stroke range: 300 to 1500 mm)

Weight

Model	11-LEJS40									
Stroke [mm]	200	300	400	500	600	700	800	900	1000	1200
Product weight [kg]	5.6	6.4	7.1	7.9	8.7	9.4	10.2	11.0	11.7	13.3
Additional weight with lock [kg]	S2: 0.2/T6: 0.2									
Model	11-LEJS63									
Stroke [mm]	300	400	500	600	700	800	900	1000	1200	1500
Product weight [kg]	11.4	12.7	13.9	15.2	16.4	17.7	18.9	20.1	22.6	26.4
Additional weight with lock [kg]	S3: 0.4/T7: 0.4									

High Rigidity Slider Type Ball Screw Drive

Clean Room Specification

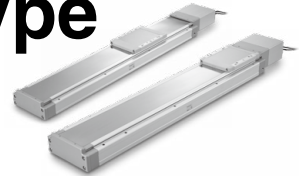

11-LEJS Series LEJS40, 63



* For details, refer to page 1343 and onward.

Refer to page 303 for model selection and page 965 for particle generation characteristics.

LECS Series ▶ p. 967

How to Order

Dimensions are the same as those of the LECS series. For details, refer to page 971 and onward.

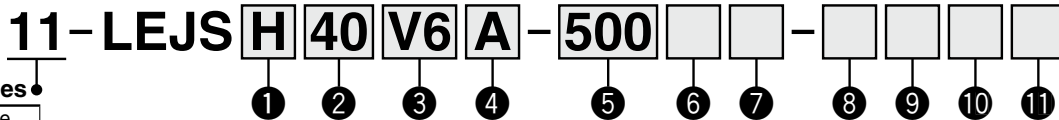

Clean series ●

11	Vacuum type
----	-------------

1 Accuracy

Nil	Basic type
H	High-precision type

2 Size

40
63

3 Motor type*1

Symbol	Type	Output [W]	2 Size	10 Driver type	Compatible*2 drivers
V6	AC servo motor (Absolute encoder)	100	40	M2	LECYM2-V5
		200	63	U2	LECYU2-V5
V7	AC servo motor (Absolute encoder)			200	63
		U2	LECYU2-V7		

*1 For motor type V6, the compatible driver part number suffix is V5.

*2 For details on the driver, refer to page 1128.

4 Lead [mm]

Symbol	LEJS40	LEJS63
A	16	20
B	8	10

5 Stroke [mm]*3

200
to
1500

*3 Refer to the applicable stroke table for details.

6 Motor option

Nil	Without option
B	With lock

7 Vacuum port*5, *6

Nil	Left
R	Right
D	Both left and right

*5 Select "D" for the vacuum port for suction of 50 L/min (ANR) or more.
*6 Vacuum piping is only built in on the vacuum port side selected at the time of purchase.

Note that after purchase, if suction is used on the port on the opposite side, the particle generation characteristics stated in the catalog may not apply.

To make any changes after purchase, be sure to contact SMC.



8 Cable type*7, *8, *9

Nil	Without cable
S	Standard cable
R	Robotic cable

*7 When a driver type is selected, a cable is included. Select the cable type and cable length.

*8 A motor cable and encoder cable are included with the product. (A lock cable is also included if motor option "B: With lock" is selected.)

*9 Standard cable entry direction is "(A) Axis side."

9 Cable length [m]*7, *10

Nil	Without cable
3	3
5	5
A	10
C	20

*10 The length of the motor, encoder, and lock cables are the same.

10 Driver type*7

	Compatible drivers	Power supply voltage [V]
Nil	Without driver	—
M2	LECYM2-V□	200 to 230
U2	LECYU2-V□	200 to 230

11 I/O cable length [m]*11

Nil	Without cable
H	Without cable (Connector only)
1	1.5

*11 When "Nil: Without driver" is selected for the driver type, only "Nil: Without cable" can be selected. Refer to page 1135 if an I/O cable is required. (Options are shown on page 1135.)

Applicable Stroke Table*4

Stroke [mm]	200	300	400	500	600	700	800	900	1000	1200	1500
Model											
11-LEJS40	●	●	●	●	●	●	●	●	●	●	—
11-LEJS63	—	●	●	●	●	●	●	●	●	●	●

*4 Please contact SMC for non-standard strokes as they are produced as special orders.

Compatible Drivers

For auto switches, refer to pages 332 to 335.

Driver type	MECHATROLINK-II type	MECHATROLINK-III type
Series	LECYM	LECYU
Applicable network	MECHATROLINK-II	MECHATROLINK-III
Control encoder	Absolute 20-bit encoder	
Communication device	USB communication, RS-422 communication	
Power supply voltage [V]	200 to 230 VAC (50/60 Hz)	
Reference page	1128	

Specifications

AC Servo Motor (100/200 W)

Model		11-LEJS40V6		11-LEJS63V7			
Actuator specifications	Stroke [mm] ^{*1}	200, 300, 400, 500, 600, 700, 800 900, 1000, 1200		300, 400, 500, 600, 700, 800, 900 1000, 1200, 1500			
	Work load [kg] ^{*2}	Horizontal	30	55	45	85	
		Vertical	5	10	10	20	
	Speed ^{*3} [mm/s]	Stroke range	Up to 500	1200	600	1200	600
			501 to 600	1050	520	1200	600
			601 to 700	780	390	1200	600
			701 to 800	600	300	930	460
			801 to 900	480	240	740	370
			901 to 1000	390	190	600	300
			1001 to 1100	320	160	500	250
			1101 to 1200	270	130	420	210
			1201 to 1300	—	—	360	180
			1301 to 1400	—	—	310	150
	1401 to 1500	—	—	270	130		
	Max. acceleration/deceleration [mm/s ²]	20000 (Refer to pages 293 and 294 for limit according to work load and duty ratio.)					
Positioning repeatability [mm]	Basic type	±0.02					
	High-precision type	±0.01					
Lost motion [mm] ^{*4}	Basic type	0.1 or less					
	High-precision type	0.05 or less					
Lead [mm]	16	8	20	10			
Impact/Vibration resistance [m/s ²] ^{*5}	50/20						
Actuation type	Ball screw						
Guide type	Linear guide						
Grease	Ball screw/Linear guide portion	Low particle generation grease					
Cleanliness class ^{*6}	ISO Class 4 (ISO 14644-1)						
Operating temperature range [°C]	5 to 40						
Operating humidity range [%RH]	90 or less (No condensation)						
Regenerative resistor	May be required depending on speed and work load (Refer to page 304.)						
Electric specifications	Motor output [W]/Size [mm]	100□40		200□60			
	Motor type	AC servo motor (200 VAC)					
	Encoder	Absolute 20-bit encoder (Resolution: 1048576 p/rev)					
Lock unit specifications	Power [W] ^{*7}	Max. power 445		Max. power 725			
	Type ^{*8}	Non-magnetizing lock					
Lock unit specifications	Holding force [N]	101	202	162	324		
	Power [W] at 20°C	5.5		6			
	Rated voltage [V]	24 VDC ^{+10%} ₀					

*1 Please contact SMC for non-standard strokes as they are produced as special orders.

*2 For details, refer to the "Speed-Work Load Graph (Guide)" on page 304.

*3 The allowable speed changes according to the stroke.

*4 A reference value for correcting errors in reciprocal operation

*5 Impact resistance: No malfunction occurred when the actuator was tested with a drop tester in both an axial direction and a perpendicular direction to the lead screw. (The test was performed with the actuator in the initial state.)

Vibration resistance: No malfunction occurred in a test ranging between 45 to 2000 Hz. The test was performed in both an axial direction and a perpendicular direction to the lead screw. (The test was performed with the actuator in the initial state.)

*6 The amount of particle generation changes according to the operating conditions and suction flow rate. Refer to the particle generation characteristics for details.

*7 Indicates the max. power during operation (including the driver)

When selecting the power supply capacity, refer to the power supply capacity in the operation manual of each driver.

*8 Only when motor option "With lock" is selected

* Sensor magnet position is located in the table center.

For detailed dimensions, refer to the "Auto Switch Mounting Position."

* Do not allow collisions at either end of the table traveling distance. Additionally, when running the positioning operation, do not set within 2 mm of both ends.

* For the manufacture of intermediate strokes, please contact SMC. (11-LEJS40/Manufacturable stroke range: 200 to 1200 mm, 11-LEJS63/Manufacturable stroke range: 300 to 1500 mm)

Weight

Model	11-LEJS40									
Stroke [mm]	200	300	400	500	600	700	800	900	1000	1200
Product weight [kg]	5.6	6.4	7.1	7.9	8.7	9.4	10.2	11.0	11.7	13.3
Additional weight with lock [kg]	0.3 (Absolute encoder)									

Model	11-LEJS63									
Stroke [mm]	300	400	500	600	700	800	900	1000	1200	1500
Product weight [kg]	11.4	12.7	13.9	15.2	16.4	17.7	18.9	20.1	22.6	26.4
Additional weight with lock [kg]	0.7 (Absolute encoder)									

11-LEJS Series

AC Servo Motor

Clean Room Specification

Dimensions: Ball Screw Drive

11-LEJS40

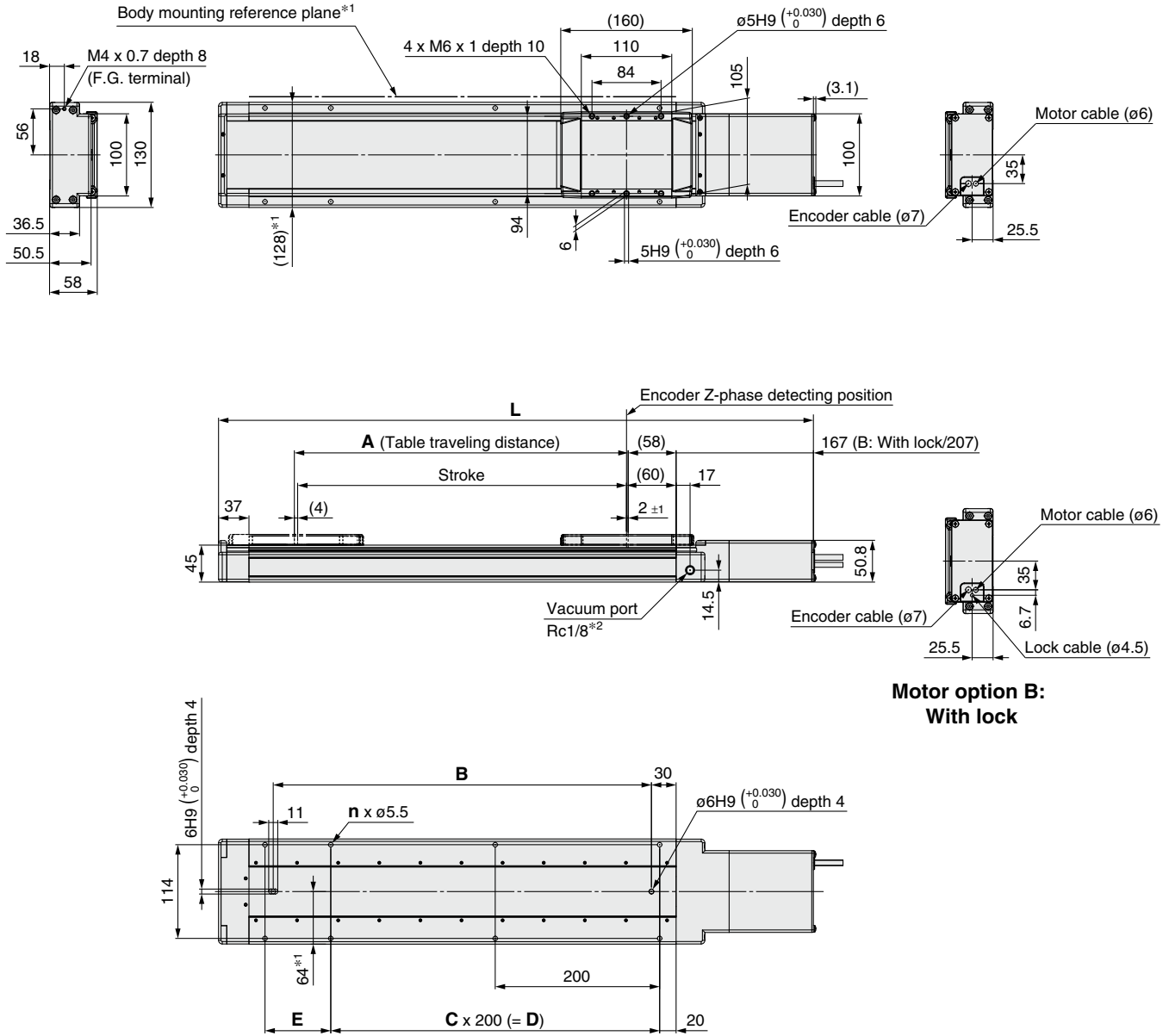

- *1 When mounting the actuator using the body mounting reference plane, use a pin. Set the height of the pin to be 5 mm or more because of round chamfering. (Recommended height: 6 mm)
- *2 This drawing shows the left type.
- * Please contact SMC for adjusting the Z-phase detecting position at the stroke end of the end side.
- * The amount of particle generation changes according to the operating conditions and suction flow rate.

Model	L		A	B	n	C	D	E
	Without lock	With lock						
11-LEJS□40□□□□-200□□-□□□□	523.5	563.5	206	260	6	1	200	80
11-LEJS□40□□□□-300□□-□□□□	623.5	663.5	306	360	6	1	200	180
11-LEJS□40□□□□-400□□-□□□□	723.5	763.5	406	460	8	2	400	80
11-LEJS□40□□□□-500□□-□□□□	823.5	863.5	506	560	8	2	400	180
11-LEJS□40□□□□-600□□-□□□□	923.5	963.5	606	660	10	3	600	80
11-LEJS□40□□□□-700□□-□□□□	1023.5	1063.5	706	760	10	3	600	180
11-LEJS□40□□□□-800□□-□□□□	1123.5	1163.5	806	860	12	4	800	80
11-LEJS□40□□□□-900□□-□□□□	1223.5	1263.5	906	960	12	4	800	180
11-LEJS□40□□□□-1000□□-□□□□	1323.5	1363.5	1006	1060	14	5	1000	80
11-LEJS□40□□□□-1200□□-□□□□	1523.5	1563.5	1206	1260	16	6	1200	80

Dimensions: Ball Screw Drive

11-LEJS63

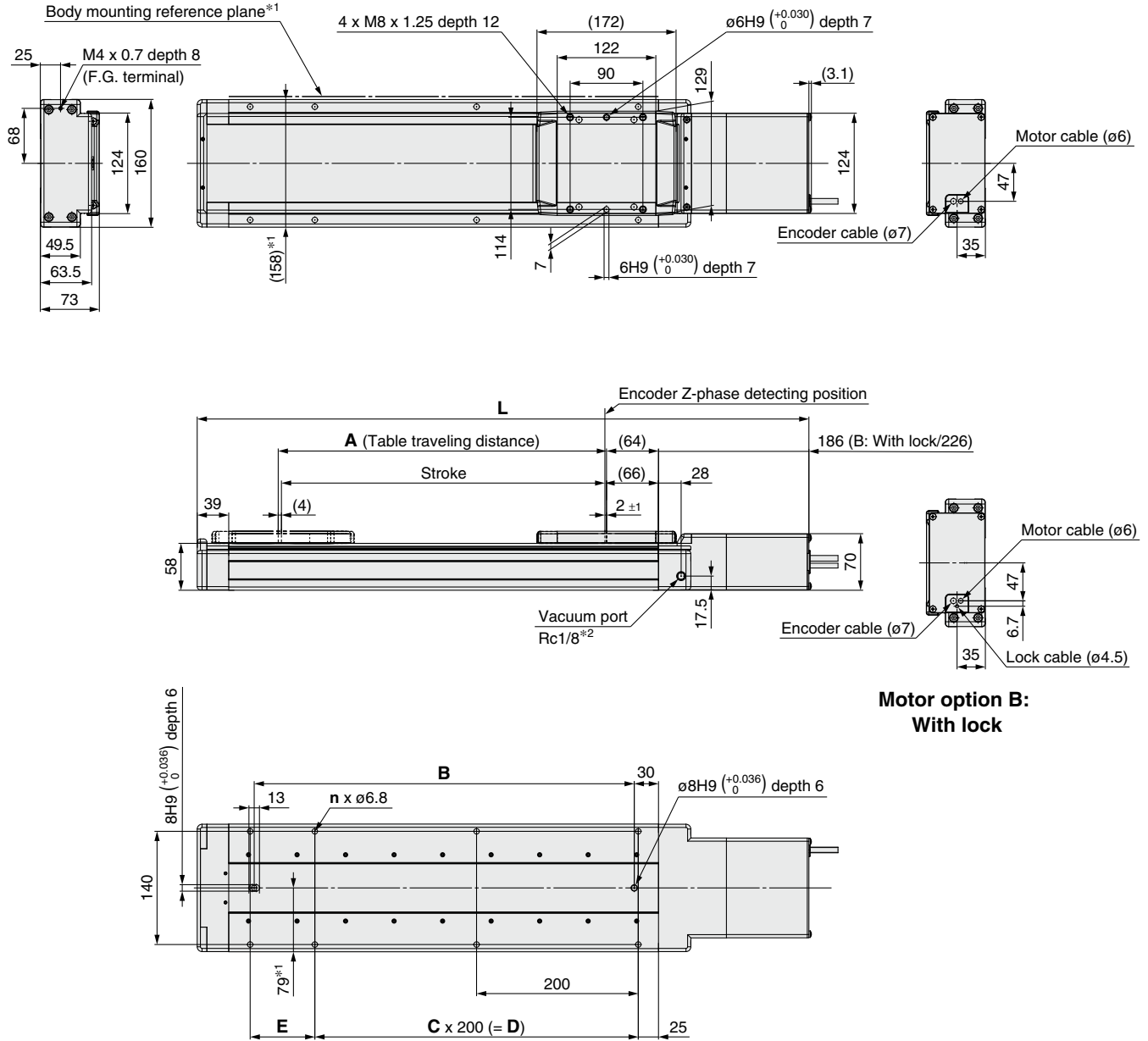

**Motor option B:
With lock**

- *1 When mounting the actuator using the body mounting reference plane, use a pin. Set the height of the pin to be 5 mm or more because of round chamfering. (Recommended height: 6 mm)
- *2 This drawing shows the left type.
- * Please contact SMC for adjusting the Z-phase detecting position at the stroke end of the end side.
- * The amount of particle generation changes according to the operating conditions and suction flow rate.

Model	L		A	B	n	C	D	E
	Without lock	With lock						
11-LEJS□63□□□□-300□□-□□□□	656.5	696.5	306	370	6	1	200	180
11-LEJS□63□□□□-400□□-□□□□	756.5	796.5	406	470	8	2	400	80
11-LEJS□63□□□□-500□□-□□□□	856.5	896.5	506	570	8	2	400	180
11-LEJS□63□□□□-600□□-□□□□	956.5	996.5	606	670	10	3	600	80
11-LEJS□63□□□□-700□□-□□□□	1056.5	1096.5	706	770	10	3	600	180
11-LEJS□63□□□□-800□□-□□□□	1156.5	1196.5	806	870	12	4	800	80
11-LEJS□63□□□□-900□□-□□□□	1256.5	1296.5	906	970	12	4	800	180
11-LEJS□63□□□□-1000□□-□□□□	1356.5	1396.5	1006	1070	14	5	1000	80
11-LEJS□63□□□□-1200□□-□□□□	1556.5	1596.5	1206	1270	16	6	1200	80
11-LEJS□63□□□□-1500□□-□□□□	1856.5	1896.5	1506	1570	18	7	1400	180