

Wide Type Parallel Style Air Gripper

ø10, ø16, ø20, ø25 ø32, ø40

RoHS

Weight

Max. **10%** reduction 585 g → **525 g**

ø16, Opening/Closing stroke: 30 mm

Weight reduced by changing the body shape and internal construction





New Added: ø32, ø40

- Dust-resistant option now available.
(Made to order: -X85, -X86□)
- Closing width adjusting option now available.
(Made to order: -X28)
- Small auto switches can be directly mounted.
 - Mounting brackets are not required. This reduces assembly labor.
 - Direct mounting is now possible due to the new groove shape.
 - Solid state auto switch: D-M9□
- Performance and mounting dimensions are interchangeable with the existing model.



3 Types of Stroke Variations

[mm]

| Opening/Closing stroke | Stroke | | | | | |
|--|--------|-----|-----|-----|-----|-----|
| | ø10 | ø16 | ø20 | ø25 | ø32 | ø40 |
| Short: MHL2-□D  | 20 | 30 | 40 | 50 | 70 | 100 |
| Medium: MHL2-□D1  | 40 | 60 | 80 | 100 | 120 | 160 |
| Long: MHL2-□D2  | 60 | 80 | 100 | 120 | 160 | 200 |

MHL2 Series



CAT.ES20-249B

Lightweight

Lightweight body achieved by changing the body shape

| Model | MHL2-□Z | MHL2 | Reduction rate [g] |
|----------|---------|------|--------------------|
| MHL2-10D | 280 | 280 | 0.0% |
| MHL2-16D | 525 | 585 | 10.3% |
| MHL2-20D | 940 | 1025 | 8.3% |
| MHL2-25D | 1565 | 1690 | 7.4% |
| MHL2-32D | 2875 | 2905 | 1.0% |
| MHL2-40D | 5230 | 5270 | 1.0% |

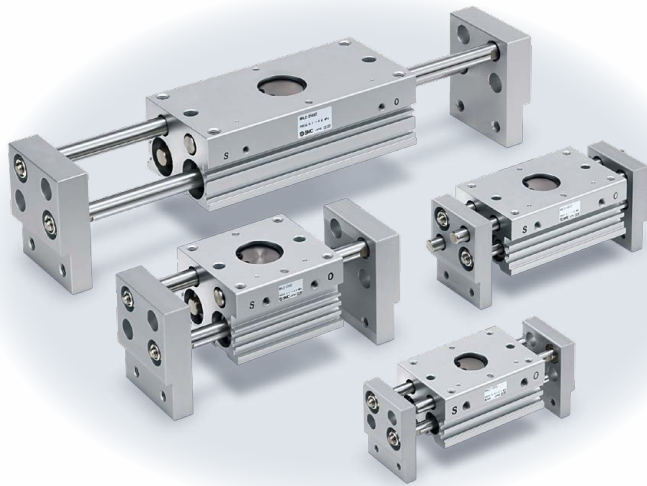

Built-in dust protection mechanism (Standard)

All rod rotating parts now feature a scraper with a dust lip.

Dust-resistant option now available. (Made to order) Pages 21 to 24

- In micro-powder (10 to 100 μm) environments → With double Lube-retainer (-X85)
 - * Prevents particles and foreign matter from entering the gripper
 - The Lube-retainer ensures a consistent film of grease, improving gripper endurance.
- In dusty environments → With heavy duty scraper + Lube-retainer (-X86□)
 - * Applicable for environments containing particles or foreign matter
 - A grease film is formed on the rod by the Lube-retainer in order to improve endurance.
 - * Seal material can be NBR or fluororubber.

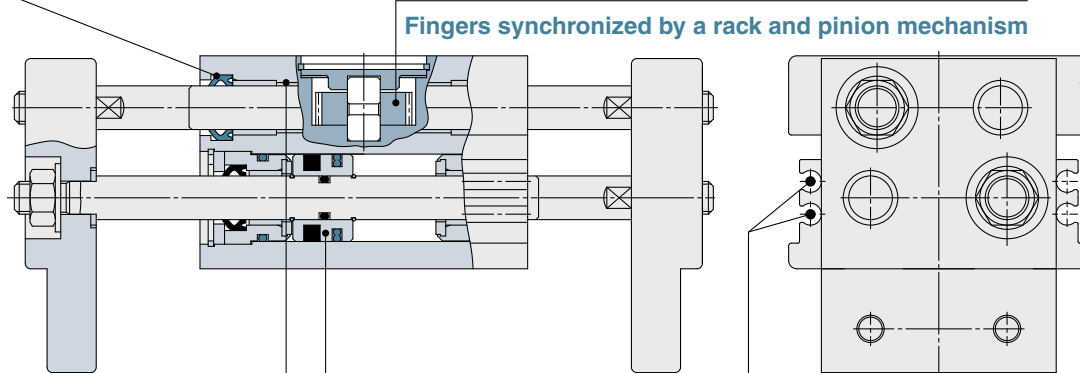
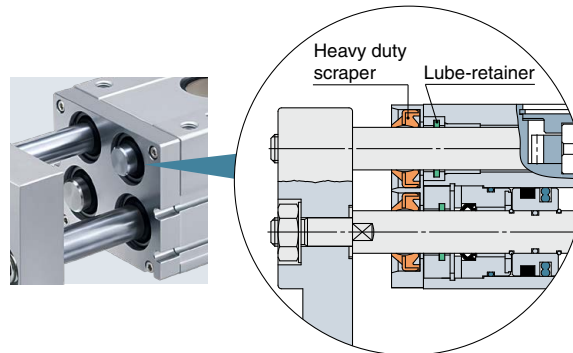
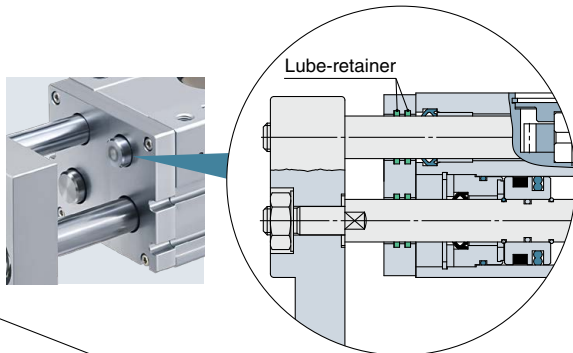

Fingers synchronized by a rack and pinion mechanism

Double-end type oil-impregnated resin bearings are used for all shafts.

A large amount of gripping force is provided, through the use of a double piston mechanism, while maintaining a compact design.

An auto switch can be mounted in 4 locations.

Series Variations

| Series | Action | Bore size [mm] | | | | | | Made to order |
|---------|---------------|----------------|----|----|----|----|----|--|
| | | 10 | 16 | 20 | 25 | 32 | 40 | |
| MHL2-□Z | Double acting | ● | ● | ● | ● | ● | ● | -X4: Heat resistant (-10 to 100°C) -X5: Fluororubber seal -X28: With bolt for adjusting the closing width -X50: Without magnet -X53: Ethylene propylene rubber seal (EPDM) -X63: Fluorine grease -X79: Grease for food processing machines: Fluorine grease -X79A: Grease for food processing machines: Aluminum complex soap base grease -X85: Fine-particle proof specification (MHL2-□Z only) -X86: With heavy duty scraper + Stable lubrication function (Lube-retainer) (NBR seals) (MHL2-□Z only) -X86A: With heavy duty scraper + Stable lubrication function (Lube-retainer) (Fluororubber seals) (MHL2-□Z only) |

CONTENTS

Wide Type Parallel Style Air Gripper *MHL2 Series*

| | |
|--|----------------|
| How to Order | Page 3 |
| Specifications | Page 4 |
| Model Selection | Page 5 |
| Construction | Page 7 |
| Dimensions | Pages 8 to 13 |
| Auto Switch Installation Examples and Mounting Positions | Pages 14, 15 |
| Auto Switch Hysteresis | Page 15 |
| Prior to Use Auto Switch Connections and Examples | Page 16 |
| Made to Order | Pages 17 to 24 |
| Specific Product Precautions | Page 25 |
| Safety Instructions | Back cover |



Wide Type Parallel Style Air Gripper

MHL2 Series

ø10, ø16, ø20, ø25, ø32, ø40



How to Order

MHL 2 - 16 □ D □ Z - M9BW □ - □

Wide type

Number of fingers

| | |
|---|---|
| 2 | 2 |
|---|---|

Bore size

| | |
|----|-------|
| 10 | 10 mm |
| 16 | 16 mm |
| 20 | 20 mm |
| 25 | 25 mm |
| 32 | 32 mm |
| 40 | 40 mm |

Port thread type

| Symbol | Type | Cylinder bore |
|--------|----------|---------------|
| Nil | M thread | ø10 to ø25 |
| | Rc | |
| TN | NPT | ø32 to ø40 |
| TF | G | |

Action

| | |
|---|---------------|
| D | Double acting |
|---|---------------|

Made to order
Refer to page 4 for details.

Number of auto switches

| | |
|-----|---|
| Nil | 2 |
| S | 1 |
| n | n |

Auto switch

| | |
|-----|---------------------------------------|
| Nil | Without auto switch (Built-in magnet) |
|-----|---------------------------------------|

* For applicable auto switches, refer to the table below.

Opening/Closing stroke [mm]

| | Symbol | ø10 | ø16 | ø20 | ø25 | ø32 | ø40 |
|------------------|--------|-----|-----|-----|-----|-----|-----|
| Short: MHL2-□D | Nil | 20 | 30 | 40 | 50 | 70 | 100 |
| Medium: MHL2-□D1 | 1 | 40 | 60 | 80 | 100 | 120 | 160 |
| Long: MHL2-□D2 | 2 | 60 | 80 | 100 | 120 | 160 | 200 |

Applicable Auto Switches/Refer to the Web Catalog for further information on auto switches.

| Type | Special function | Electrical entry | Indicator light | Wiring (Output) | Load voltage | | Auto switch model | | Lead wire length [m]*1 | | | | Pre-wired connector | Applicable load | | |
|-------------------------|-------------------------------------|------------------|-----------------|-----------------|--------------|-----------|-------------------|---------|------------------------|--------|-------|------------|---------------------|-----------------|------------|------------|
| | | | | | DC | AC | Perpendicular | In-line | 0.5 (Nil) | 1 (M) | 3 (L) | 5 (Z) | | IC circuit | Relay, PLC | |
| Solid state auto switch | — | Grommet | Yes | 3-wire (NPN) | 24 V | 5 V, 12 V | — | M9NV | M9N | ● | ● | ● | ○ | ○ | IC circuit | Relay, PLC |
| | | | | 3-wire (PNP) | | | | M9PV | M9P | ● | ● | ● | ○ | ○ | | |
| | | | | 2-wire | | | | M9BV | M9B | ● | ● | ● | ○ | ○ | | |
| | 3-wire (NPN) | | | 5 V, 12 V | M9NWV | M9NW | ● | ● | ● | ○ | ○ | IC circuit | | | | |
| | 3-wire (PNP) | | | | M9PWV | M9PW | ● | ● | ● | ○ | ○ | | | | | |
| | 2-wire | | | | M9BWV | M9BW | ● | ● | ● | ○ | ○ | | | | | |
| | Water resistant (2-color indicator) | Grommet | Yes | No | 3-wire (NPN) | 24 V | 5 V, 12 V | — | M9NAV*2 | M9NA*2 | ○ | ○ | ● | ○ | ○ | IC circuit |
| | | | | | 3-wire (PNP) | | | | M9PAV*2 | M9PA*2 | ○ | ○ | ● | ○ | ○ | |
| | | | | | 2-wire | | | | M9BAV*2 | M9BA*2 | ○ | ○ | ● | ○ | ○ | |
| | | | | | 2-wire | | | | | | ○ | ○ | ● | ○ | ○ | |

*1 Lead wire length symbols: 0.5 m..... Nil (Example) M9NW
 1 m..... M (Example) M9NWM
 3 m..... L (Example) M9NWL
 5 m..... Z (Example) M9NWZ

*2 Water resistant type auto switches can be mounted on the above models, but SMC cannot guarantee water resistance.

* Solid state auto switches marked with "○" are produced upon receipt of order.

* When using the 2-color indicator type, please make the setting so that the indicator is lit in red to ensure the detection at the proper position of the air gripper.

Long stroke

One unit can handle workpieces with various diameters.

A large amount of gripping force is provided, through the use of a double piston mechanism, while maintaining a compact design.

Double-end type oil-impregnated resin bearings are used for all shafts.

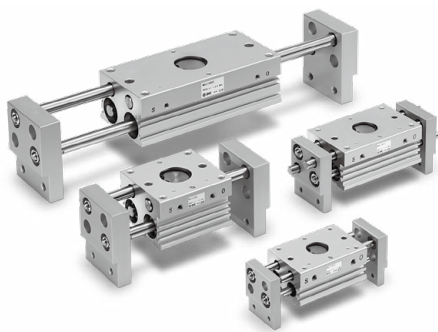

Symbol

Double acting: Internal grip Double acting: External grip

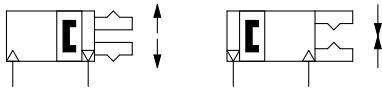

Made to Order
(For details, refer to pages 17 to 24.)

| Symbol | Specifications |
|--------|---|
| -X4 | Heat resistant (-10 to 100°C) |
| -X5 | Fluororubber seal |
| -X28 | With bolt for adjusting the closing width |
| -X50 | Without magnet |
| -X53 | Ethylene propylene rubber seal (EPDM) |
| -X63 | Fluorine grease |
| -X79 | Grease for food processing machines: Fluorine grease |
| -X79A | Grease for food processing machines: Aluminum complex soap base grease |
| -X85 | Fine-particle proof specification (Lube-retainer) |
| -X86□ | With heavy duty scraper + Stable lubrication function (Lube-retainer) (Heavy duty scraper material: NBR, Fluororubber) |

Refer to pages 14 and 15 for cylinders with auto switches.

- Auto Switch Installation Examples and Mounting Positions
- Auto Switch Hysteresis

Specifications

| Bore size [mm] | 10 | 16 | 20 | 25 | 32 | 40 |
|---|---------------------------|------------|----|-----|-----|-----|
| Fluid | Air | | | | | |
| Action | Double acting | | | | | |
| Operating pressure [MPa] | 0.15 to 0.6 | 0.1 to 0.6 | | | | |
| Ambient and fluid temperatures | -10 to 60°C (No freezing) | | | | | |
| Repeatability | ±0.1 | | | | | |
| Lubricant | Non-lube | | | | | |
| Effective gripping force [N]*1 at 0.5 MPa | 14 | 45 | 74 | 131 | 228 | 396 |

*1 Gripping point distance = Bore size 10, 16, 20, 25: 40 mm, Bore size 32, 40: 80 mm

Model/Stroke

| Model | Bore size [mm] | Max. operating frequency [c.p.m] | Opening/Closing stroke [mm] (L2-L1) | Closing width [mm] (L1) | Opening width [mm] (L2) | Weight [g] |
|------------|----------------|----------------------------------|-------------------------------------|-------------------------|-------------------------|------------|
| MHL2-10DZ | 10 | 60 | 20 | 56 | 76 | 280 |
| MHL2-10D1Z | | 40 | 40 | 78 | 118 | 355 |
| MHL2-10D2Z | | | 60 | 96 | 156 | 430 |
| MHL2-16DZ | 16 | 60 | 30 | 68 | 98 | 525 |
| MHL2-16D1Z | | 40 | 60 | 110 | 170 | 725 |
| MHL2-16D2Z | | | 80 | 130 | 210 | 845 |
| MHL2-20DZ | 20 | 60 | 40 | 82 | 122 | 940 |
| MHL2-20D1Z | | 40 | 80 | 142 | 222 | 1335 |
| MHL2-20D2Z | | | 100 | 162 | 262 | 1520 |
| MHL2-25DZ | 25 | 60 | 50 | 100 | 150 | 1565 |
| MHL2-25D1Z | | 40 | 100 | 182 | 282 | 2295 |
| MHL2-25D2Z | | | 120 | 200 | 320 | 2525 |
| MHL2-32DZ | 32 | 30 | 70 | 150 | 220 | 2875 |
| MHL2-32D1Z | | 20 | 120 | 198 | 318 | 3770 |
| MHL2-32D2Z | | | 160 | 242 | 402 | 4585 |
| MHL2-40DZ | 40 | 30 | 100 | 188 | 288 | 5230 |
| MHL2-40D1Z | | 20 | 160 | 246 | 406 | 6760 |
| MHL2-40D2Z | | | 200 | 286 | 486 | 7825 |

* The opening and closing widths represent the value when gripping the exterior of a workpiece.

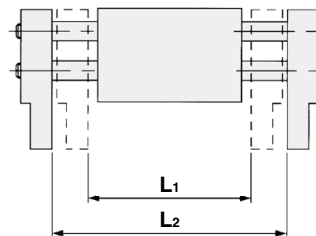

⚠ Specific Product Precautions

Be sure to read this before handling the products. Refer to page 25 for details.

MHL2 Series

Model Selection

Step 1 Check the gripping force.

Step 2 Check the gripping point.

Step 1 Check the gripping force.

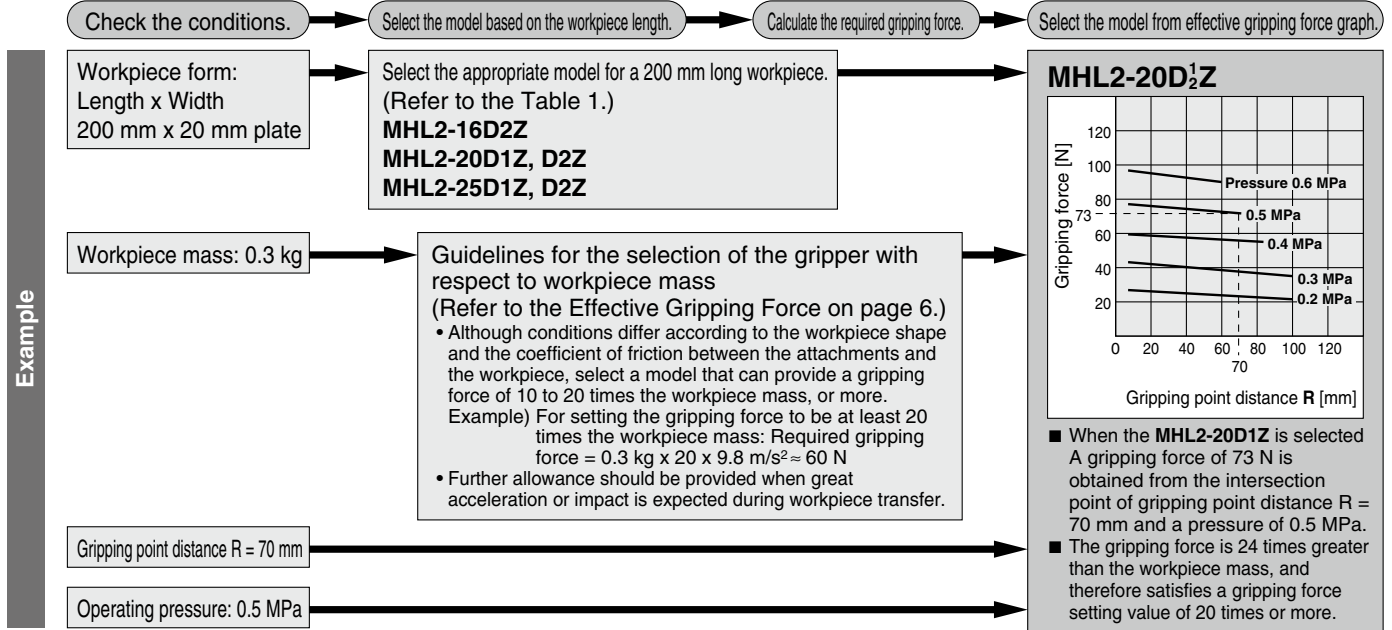
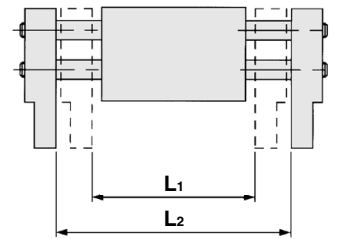

Table 1

| Model | Bore size [mm] | Closing width [mm] (L1) | Opening width [mm] (L2) | Model | Bore size [mm] | Closing width [mm] (L1) | Opening width [mm] (L2) |
|------------|----------------|-------------------------|-------------------------|------------|----------------|-------------------------|-------------------------|
| MHL2-10DZ | 10 | 56 | 76 | MHL2-25DZ | 25 | 100 | 150 |
| MHL2-10D1Z | | 78 | 118 | MHL2-25D1Z | | 182 | 282 |
| MHL2-10D2Z | | 96 | 156 | MHL2-25D2Z | | 200 | 320 |
| MHL2-16DZ | 16 | 68 | 98 | MHL2-32DZ | 32 | 150 | 220 |
| MHL2-16D1Z | | 110 | 170 | MHL2-32D1Z | | 198 | 318 |
| MHL2-16D2Z | | 130 | 210 | MHL2-32D2Z | | 242 | 402 |
| MHL2-20DZ | 20 | 82 | 122 | MHL2-40DZ | 40 | 188 | 288 |
| MHL2-20D1Z | | 142 | 222 | MHL2-40D1Z | | 246 | 406 |
| MHL2-20D2Z | | 162 | 262 | MHL2-40D2Z | | 286 | 486 |



* The opening and closing widths represent the value when gripping the exterior of a workpiece.

Calculation of Required Gripping Force

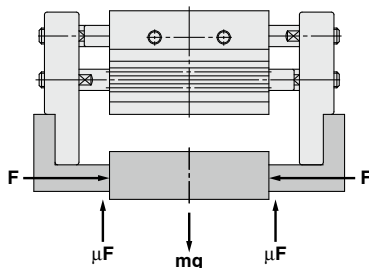

“Gripping force at least 10 to 20 times the workpiece weight”

• The “10 to 20 times or more of the workpiece weight” recommended by SMC is calculated with a margin of “a” = 4, which allows for impacts that occur during normal transportation, etc.

| When $\mu = 0.2$ | When $\mu = 0.1$ |
|--|--|
| $F = \frac{mg}{2 \times 0.2} \times 4$ | $F = \frac{mg}{2 \times 0.1} \times 4$ |
| $= 10 \times mg$ | $= 20 \times mg$ |

10 x Workpiece weight

20 x Workpiece weight

When gripping a workpiece as in the figure to the left, and with the following definitions,

F: Gripping force [N]

μ : Coefficient of friction between the attachments and the workpiece

m: Workpiece mass [kg]

g: Gravitational acceleration (= 9.8 m/s²)

mg: Workpiece weight [N]

the conditions under which the workpiece will not drop are

$$2 \times \mu F > mg$$

↑ Number of fingers

and therefore,

$$F > \frac{mg}{2 \times \mu}$$

With “a” representing the margin, “F” is determined by the following formula:

$$F = \frac{mg}{2 \times \mu} \times a$$

* Even in cases where the coefficient of friction is greater than $\mu = 0.2$, for reasons of safety, select a gripping force which is at least 10 to 20 times greater than the workpiece weight, as recommended by SMC.
• If high acceleration or impact forces are encountered during motion, a further margin should be considered.

Effective Gripping Force

• Indication of effective gripping force

The gripping force shown in the tables represents the gripping force of one finger when all fingers and attachments are in contact with the workpiece.

F = One finger thrust

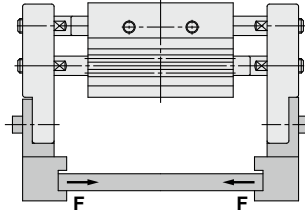

MHL2-10DZ

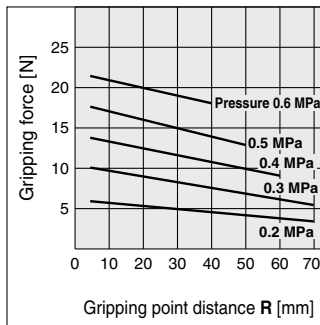

MHL2-10D₂Z

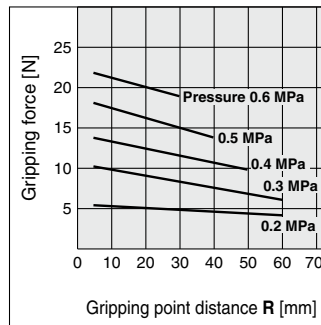

MHL2-16DZ

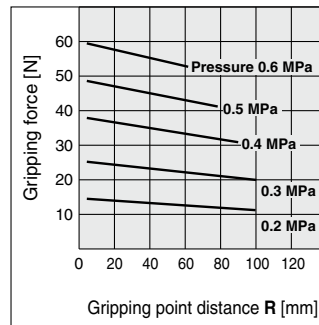

MHL2-16D₂Z

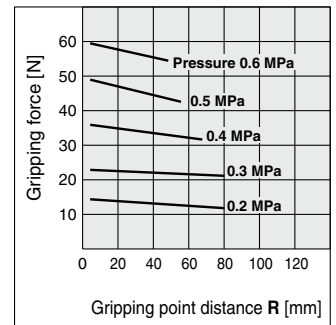

MHL2-20DZ

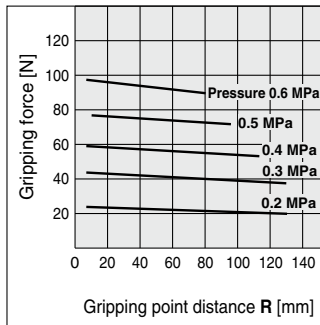

MHL2-20D₂Z

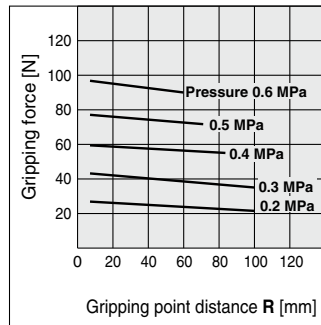

MHL2-25DZ

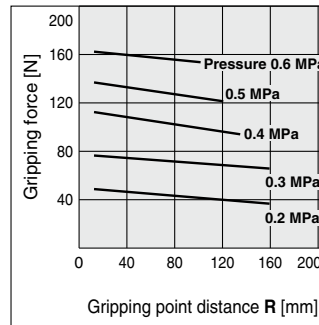

MHL2-25D₂Z

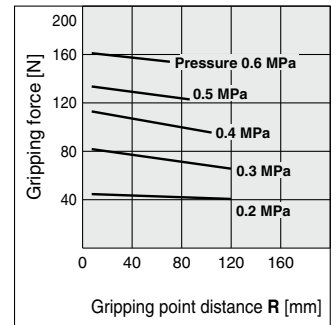

MHL2-32DZ

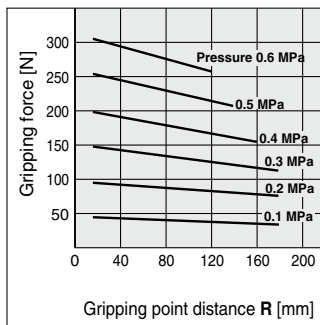

MHL2-32D₂Z

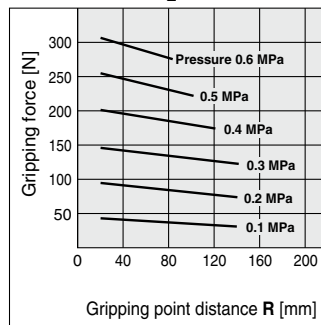

MHL2-40DZ

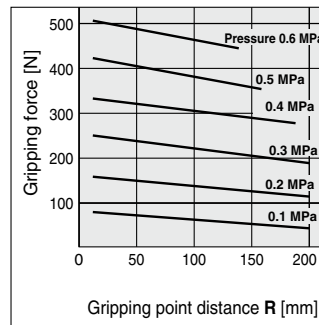

MHL2-40D₂Z

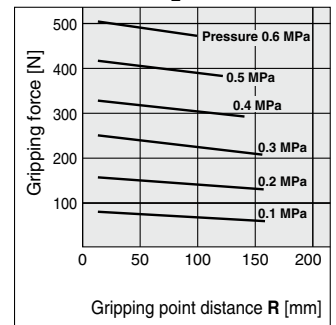

Step 2 Check the gripping point.

- The workpiece gripping point distance should be within the gripping force ranges given for each pressure in the effective gripping force graphs above.
- If operated with the workpiece gripping point beyond the indicated ranges, the load that will be applied to the fingers or the guide will become excessively unbalanced. As a result, the fingers could become loosened and adversely affect the service life of the unit.

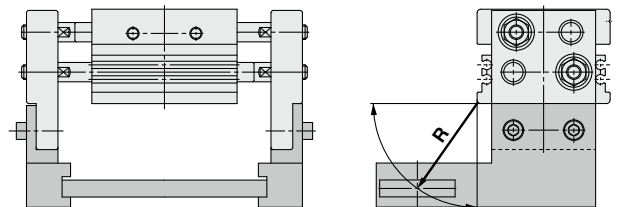

R: Gripping point distance [mm]

MHL2 Series

Construction

ø10

ø16 to ø40

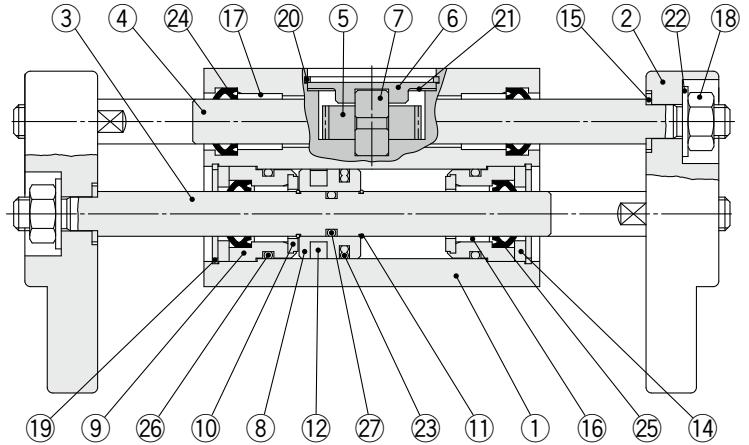
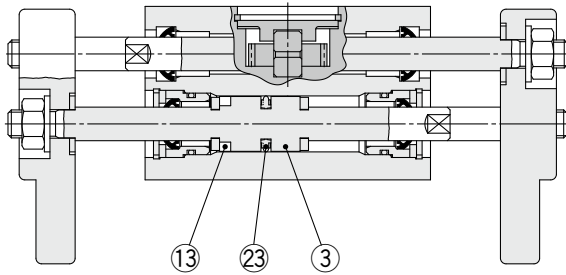

Component Parts

| No. | Description | Material | Note |
|-----|------------------|--------------------------------|----------------------------|
| 1 | Body | Aluminum alloy | Hard anodized |
| 2 | Finger | Aluminum alloy | Hard anodized |
| 3 | Piston rod | Stainless steel | |
| 4 | Rack | Stainless steel | |
| 5 | Pinion | Carbon steel | |
| 6 | Pinion cover | Carbon steel | Electroless nickel plating |
| 7 | Pinion axis | Stainless steel | |
| 8 | Piston | Aluminum alloy | Hard anodized |
| 9 | Rod cover | Aluminum alloy | Trivalent chromated |
| 10 | Bumper | Urethane rubber | |
| 11 | Clip | Stainless steel spring wire | |
| 12 | Rubber magnet | Synthetic rubber | |
| 13 | Magnet | — | Nickel plating |
| 14 | Rod seal cover B | Cold rolled carbon steel sheet | Electroless nickel plating |

| No. | Description | Material | Note |
|-----|----------------------------------|---------------------------|---------------------|
| 15 | Washer | Stainless steel | |
| 16 | Bearing | Oil containing polyacetal | |
| 17 | Bearing | Oil containing polyacetal | |
| 18 | U-nut | Carbon steel | Trivalent chromated |
| 19 | Inverted internal retaining ring | Carbon steel | Phosphate coating |
| 20 | C type retaining ring | Carbon steel | Phosphate coating |
| 21 | Wave washer | Steel for spring | Phosphate coating |
| 22 | Conical spring washer | Carbon steel | |
| 23 | Piston seal | NBR | |
| 24 | Rod seal | NBR | |
| 25 | Rod seal | NBR | |
| 26 | Gasket | NBR | |
| 27 | Gasket | NBR | |

Replacement Parts

| Description | MHL2-10□Z | MHL2-16□Z | MHL2-20□Z | MHL2-25□Z | MHL2-32□Z | MHL2-40□Z | Contents | |
|---------------------------|------------|------------|------------|------------|------------|------------|---|-------------------------------|
| Seal kit | MHL10-PS | MHL16-PS | MHL20-PS | MHL25-PS | MHL32-PS | MHL40-PS | 23, 24, 25, 26, 27 | |
| Piston assembly | MHL2-□□DZ | MHL-AA1001 | MHL-AA1601 | MHL-AA2001 | MHL-AA2501 | MHL-AA3201 | MHL-AA4001 | ø10: 3, 10, 13, 23 |
| | MHL2-□□D1Z | MHL-AA1002 | MHL-AA1602 | MHL-AA2002 | MHL-AA2502 | MHL-AA3202 | MHL-AA4002 | ø16 to ø40: 3, 8, 11, 12, 23, |
| | MHL2-□□D2Z | MHL-AA1003 | MHL-AA1603 | MHL-AA2003 | MHL-AA2503 | MHL-AA3203 | MHL-AA4003 | 27 |
| Rack | MHL2-□□DZ | MHL-AA1004 | MHL-AA1604 | MHL-AA2004 | MHL-AA2504 | MHL-AA3204 | MHL-AA4004 | 4 |
| | MHL2-□□D1Z | MHL-AA1005 | MHL-AA1605 | MHL-AA2005 | MHL-AA2505 | MHL-AA3205 | MHL-AA4005 | |
| | MHL2-□□D2Z | MHL-AA1006 | MHL-AA1606 | MHL-AA2006 | MHL-AA2506 | MHL-AA3206 | MHL-AA4006 | |
| Rod cover assembly | MHL-AA1007 | MHL-AA1607 | MHL-AA2007 | MHL-AA2507 | MHL-AA3207 | MHL-AA4007 | ø10: 9, 14, 16, 19, 25, 26 ø16 to ø40: 9, 10, 14, 16, 19, 25, 26 | |
| Finger assembly | MHL-AA1008 | MHL-AA1608 | MHL-AA2008 | MHL-AA2508 | MHL-AA3208 | MHL-AA4008 | 2, 15, 18, 22 | |
| Pinion assembly | MHL-AA1009 | MHL-AA1609 | MHL-AA2009 | MHL-AA2509 | MHL-AA3209 | MHL-AA4009 | 5, 6, 7, 20, 21 | |
| Nut set | MHL-A1017 | MHL-A1617 | MHL-A2017 | MHL-A2517 | MHL-A3217 | MHL-A4017 | 15, 18, 22 | |
| U-nut assembly | MHL-A1017A | MHL-A1617A | MHL-A2017A | MHL-A2517A | MHL-A3217A | MHL-A4017A | 18, 22 | |

- * Order one finger assembly, pinion assembly, nut set and U-nut assembly per unit.
- * For piston assembly and rack, order 2 pieces per unit.
- * For rod cover assembly, order 4 pieces per unit.
- * The seal kit does not include a grease pack. Order it separately.

Replacement Parts/Grease Pack Part Nos.

| | |
|------------------------|--|
| MHL2-□□DZ (ø10 to ø20) | GR-S-010 (10 g) |
| MHL2-□□DZ (ø25, ø32) | GR-S-010 (10 g) |
| MHL2-□□DZ (ø40) | GR-S-020 (20 g) |
| MHL2-□□D1Z (ø10, ø16) | GR-S-010 (10 g) |
| MHL2-□□D1Z (ø20, ø25) | GR-S-010 (10 g) |
| MHL2-□□D1Z (ø32, ø40) | GR-S-020 (20 g) |
| MHL2-□□D2Z (ø10, ø16) | GR-S-010 (10 g) |
| MHL2-□□D2Z (ø20, ø25) | GR-S-010 (10 g) |
| MHL2-□□D2Z (ø32, ø40) | GR-S-010 (10 g), GR-S-020 (20 g) (1 pack each) |

Dimensions

MHL2-10D□Z

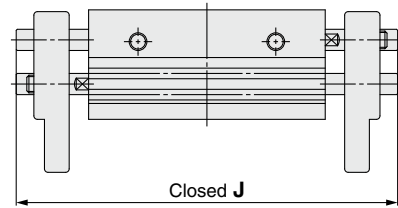
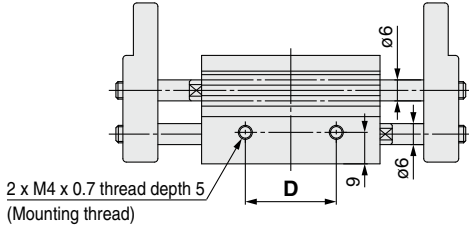

View K (Fingers closed)

* The above figure shows the MHL2-10D1Z/10D2Z.

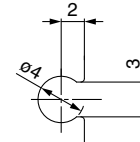
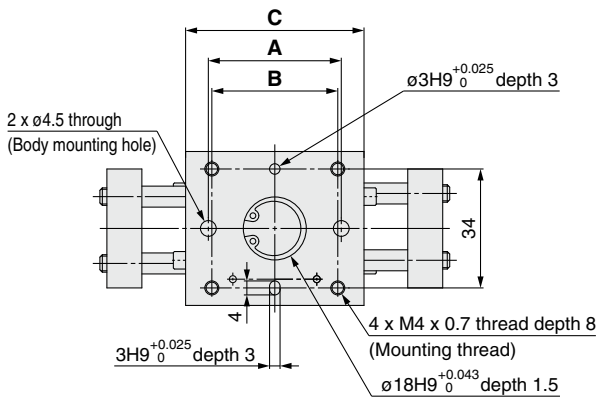

***1 Dimensions of auto switch mounting groove (Enlarged view)**

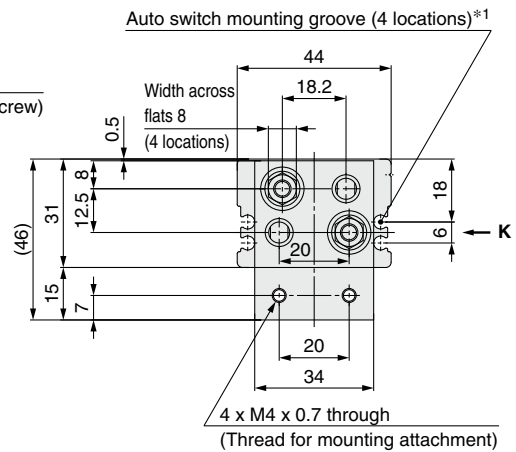
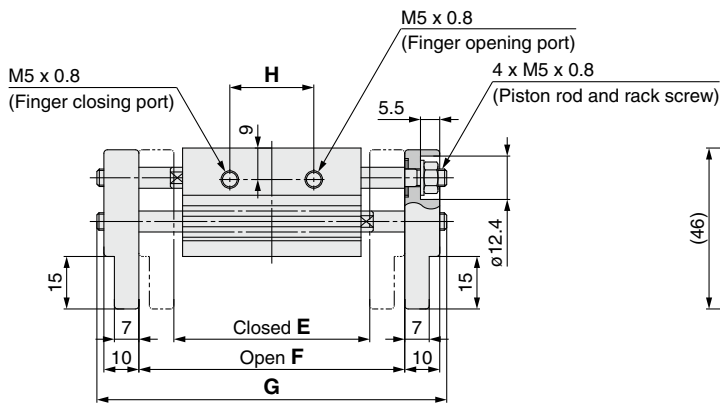

| Model | A | B | C | D | E | F | G | H | J |
|------------|----|----|----|----|----|-----|-----|----|-----|
| MHL2-10DZ | 38 | 36 | 51 | 26 | 56 | 76 | 100 | 24 | 80 |
| MHL2-10D1Z | 54 | 52 | 67 | 42 | 78 | 118 | 142 | 39 | 108 |
| MHL2-10D2Z | 72 | 70 | 85 | 60 | 96 | 156 | 180 | 57 | 146 |

* J-dimension is at fully closed.

* D1Z is different from D2Z at finger closed because shaft is ejected from finger end.
J-dimension is different from the value which is subtracted stroke from G-dimension.

MHL2 Series

Dimensions

MHL2-16D□Z

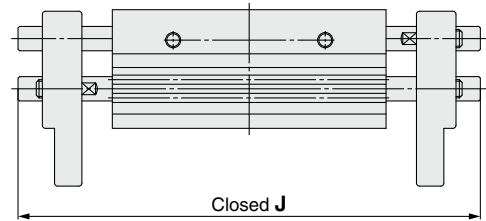
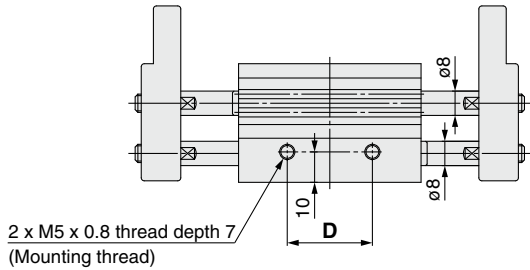

View K (Fingers closed)

* The above figure shows the MHL2-16D1Z/16D2Z.

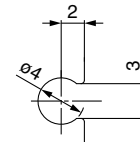
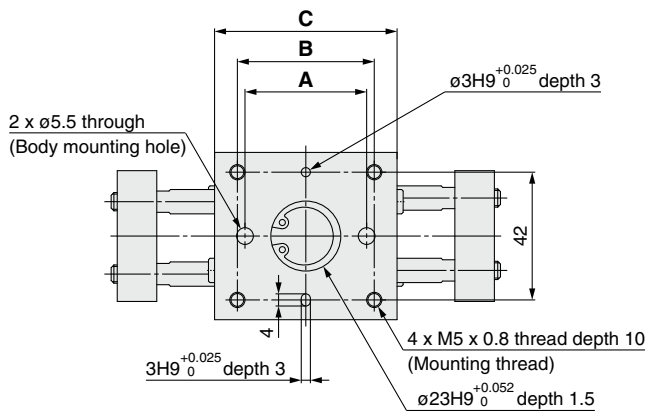

***1 Dimensions of auto switch mounting groove (Enlarged view)**

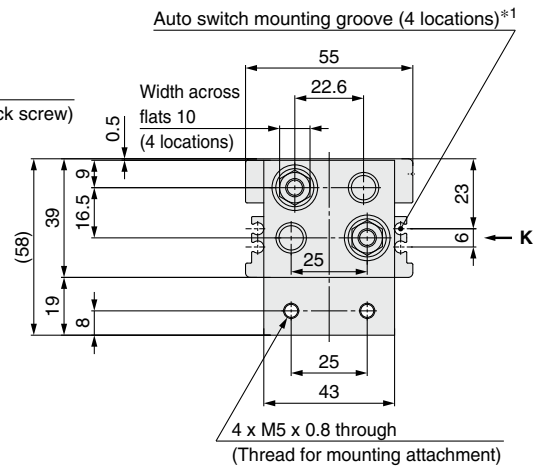
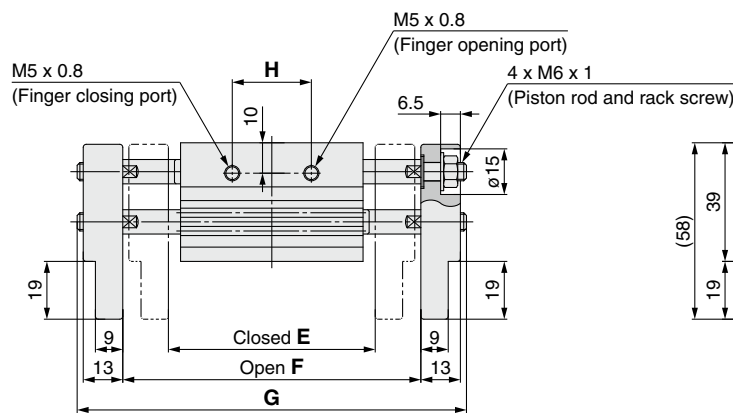

| Model | A | B | C | D | E | F | G | H | J |
|------------|----|----|-----|----|-----|-----|-----|----|-----|
| MHL2-16DZ | 40 | 45 | 60 | 28 | 68 | 98 | 128 | 26 | 98 |
| MHL2-16D1Z | 70 | 75 | 90 | 58 | 110 | 170 | 200 | 50 | 152 |
| MHL2-16D2Z | 90 | 95 | 110 | 78 | 130 | 210 | 240 | 70 | 192 |

* J-dimension is at fully closed.

* D1Z is different from D2Z at finger closed because shaft is ejected from finger end.
J-dimension is different from the value which is subtracted stroke from G-dimension.

Dimensions

MHL2-20D□Z

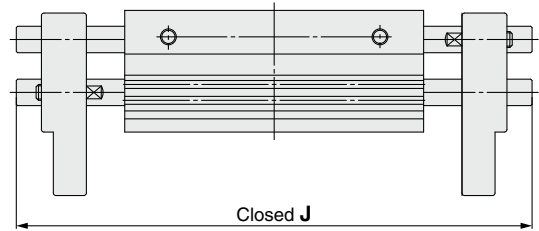
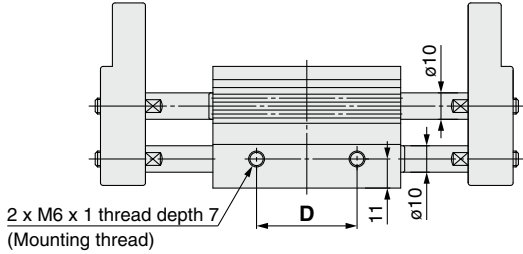

View K (Fingers closed)

* The above figure shows the MHL2-20D1Z/20D2Z.

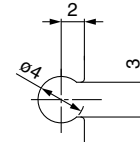
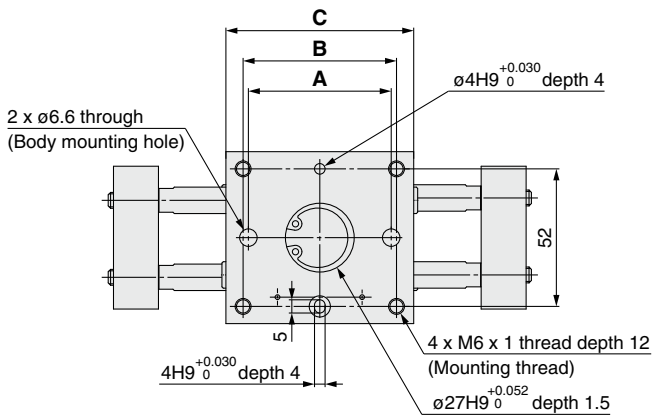

***1 Dimensions of auto switch mounting groove (Enlarged view)**

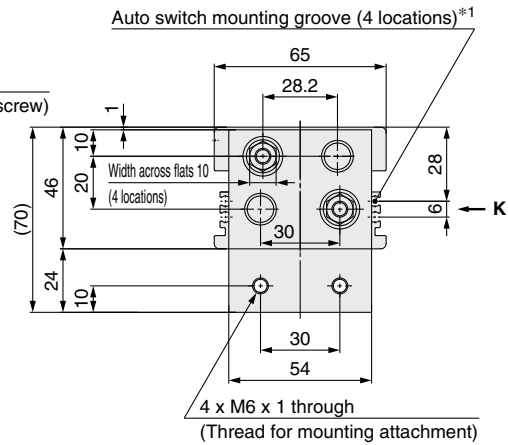
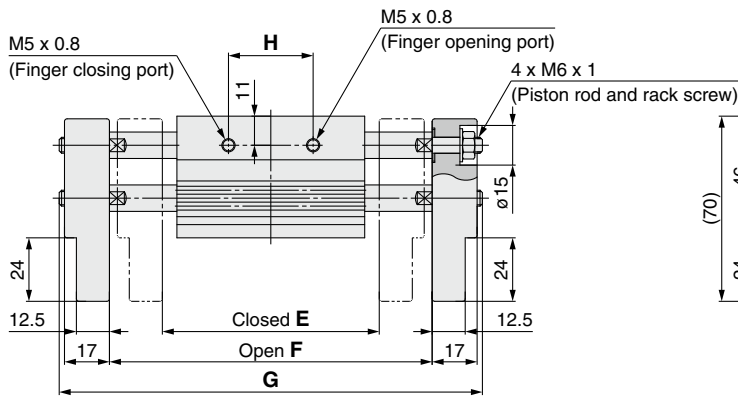

| Model | A | B | C | D | E | F | G | H | J |
|-------------------|-----|-----|-----|-----|-----|-----|-----|----|-----|
| MHL2-20DZ | 54 | 58 | 71 | 38 | 82 | 122 | 160 | 32 | 120 |
| MHL2-20D1Z | 96 | 100 | 113 | 80 | 142 | 222 | 260 | 68 | 195 |
| MHL2-20D2Z | 116 | 120 | 133 | 100 | 162 | 262 | 300 | 88 | 235 |

* J-dimension is at fully closed.

* D1Z is different from D2Z at finger closed because shaft is ejected from finger end.
J-dimension is different from the value which is subtracted stroke from G-dimension.

Dimensions

MHL2-32D□Z

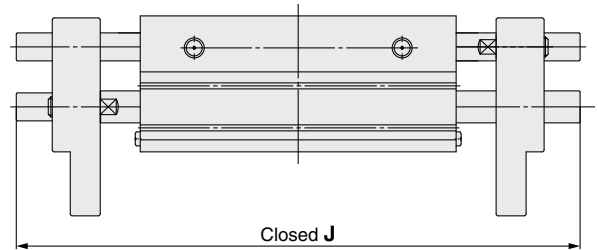
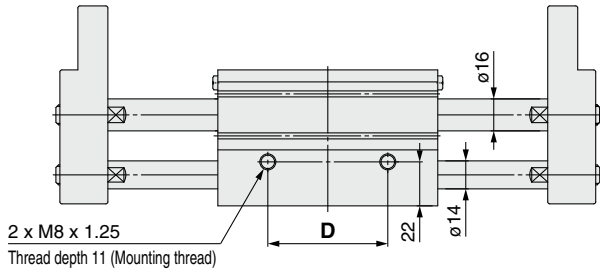

View K (Fingers closed)

* The above figure shows the MHL2-32D1Z/32D2Z.

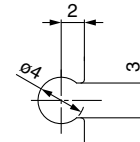
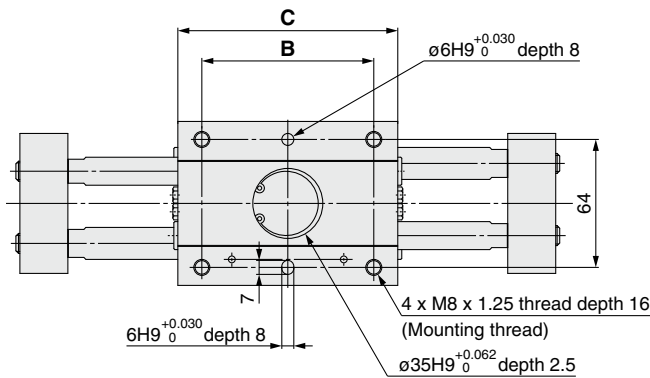

***1 Dimensions of auto switch mounting groove (Enlarged view)**

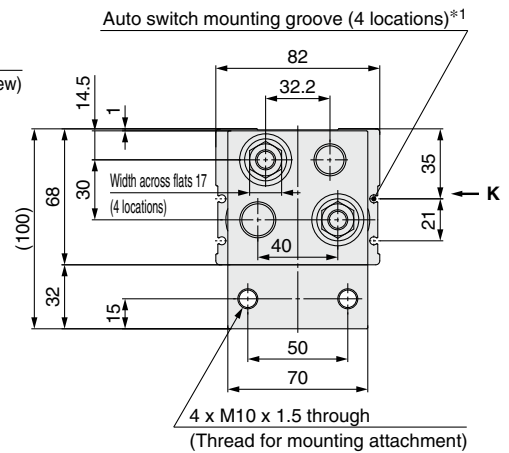
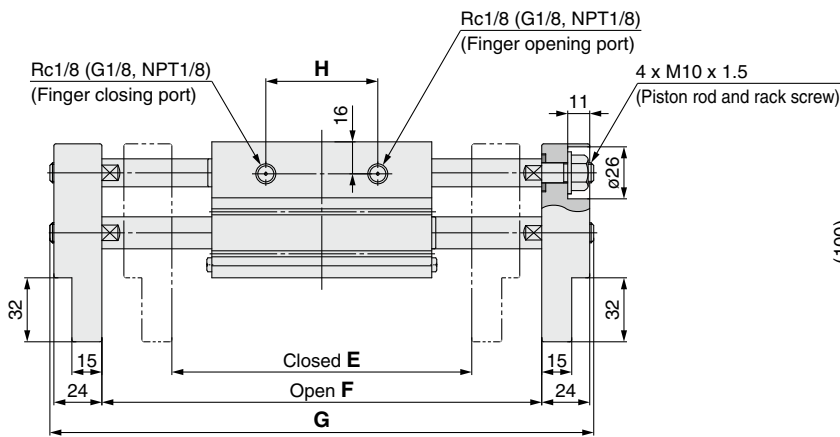

| Model | B | C | D | E | F | G | H | J |
|-------------------|-----|-----|-----|-----|-----|-----|-----|-----|
| MHL2-32DZ | 86 | 110 | 60 | 150 | 220 | 272 | 56 | 202 |
| MHL2-32D1Z | 134 | 158 | 108 | 198 | 318 | 370 | 104 | 282 |
| MHL2-32D2Z | 178 | 202 | 152 | 242 | 402 | 454 | 148 | 366 |

* J-dimension is at fully closed.

* D1Z is different from D2Z at finger closed because shaft is ejected from finger end.

J-dimension is different from the value which is subtracted stroke from G-dimension.

MHL2 Series

Dimensions

MHL2-40D□Z

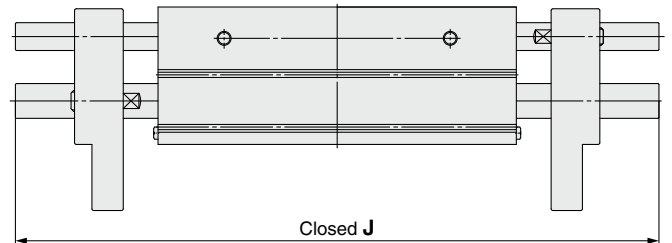
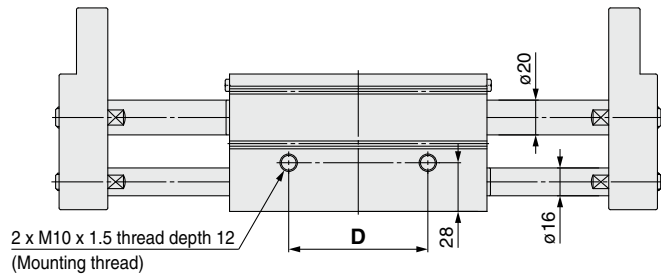

View K (Fingers closed)

* The above figure shows the MHL2-40D1Z/40D2Z.

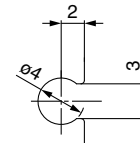

*** 1 Dimensions of auto switch mounting groove (Enlarged view)**

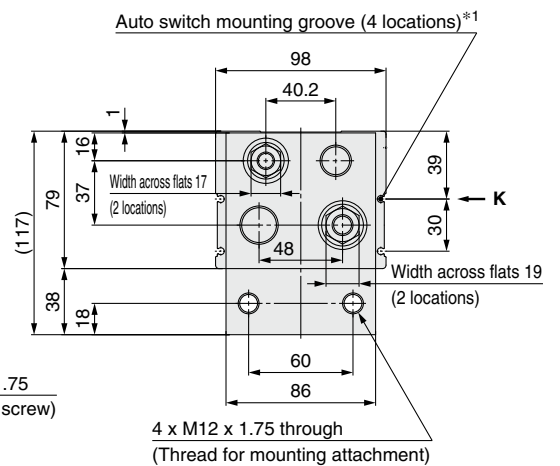
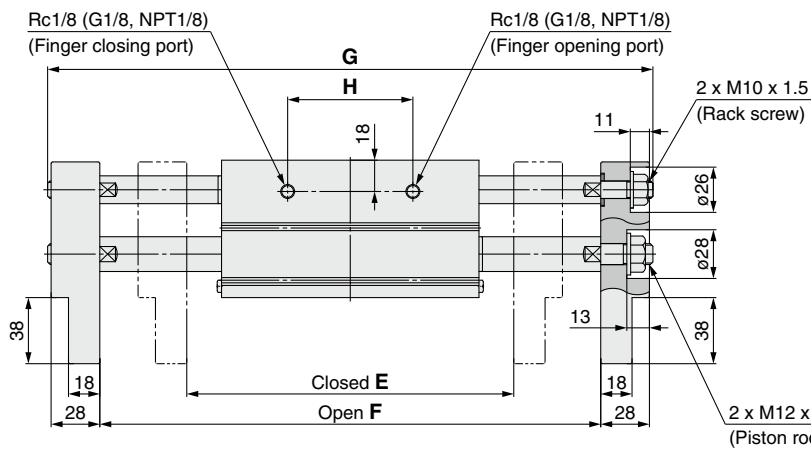
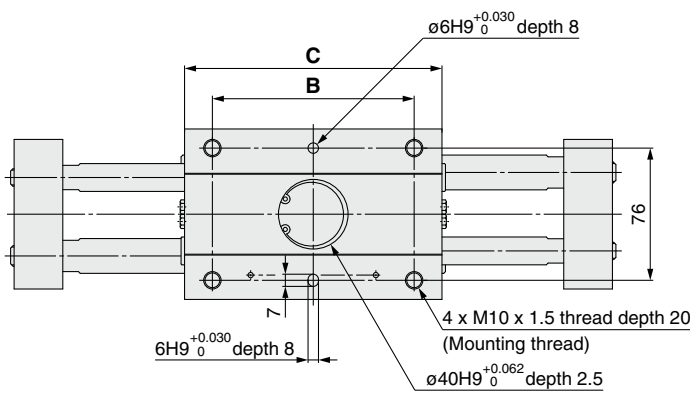

| Model | B | C | D | E | F | G | H | J |
|------------|-----|-----|-----|-----|-----|-----|-----|-----|
| MHL2-40DZ | 116 | 148 | 80 | 188 | 288 | 348 | 72 | 252 |
| MHL2-40D1Z | 174 | 206 | 138 | 246 | 406 | 466 | 130 | 370 |
| MHL2-40D2Z | 214 | 246 | 178 | 286 | 486 | 546 | 170 | 450 |

* J-dimension is at fully closed.

* D1Z is different from D2Z at finger closed because shaft is ejected from finger end.

J-dimension is different from the value which is subtracted stroke from G-dimension.

MHL2 Series

Auto Switch Installation Examples and Mounting Positions

Various auto switch applications are possible through different combinations of auto switch quantities and detecting positions.

1) Detection when Gripping Exterior of Workpiece

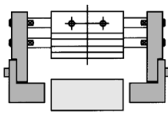
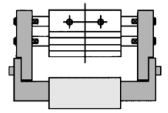
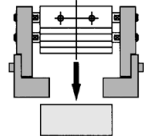
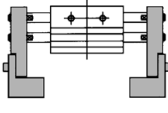
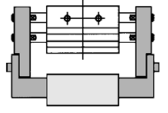
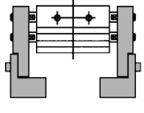
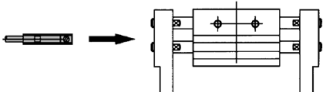
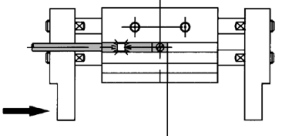
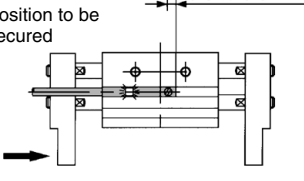
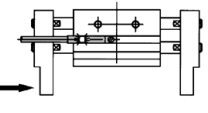
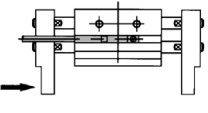
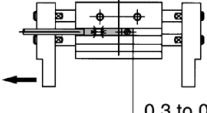
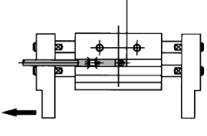
| Detection example | | ① Confirmation of fingers in reset position | ② Confirmation of workpiece held | ③ Confirmation of workpiece released | |
|---|---|---|--|--|---|
| Position to be detected | | Position of fingers fully open  | Position when gripping a workpiece  | Position of fingers fully closed  | |
| Operation of auto switch | | When fingers return: Auto switch to turn ON (Light ON) | When gripping a workpiece: Auto switch to turn ON (Light ON) | When a workpiece is not held (Abnormal operation): Auto switch to turn ON (Light ON) | |
| Detection combinations | One auto switch * One position, any of ①, ② and ③ can be detected. | ● | ● | ● | |
| | Two auto switches * Two positions of ①, ② and ③ can be detected. | Pattern A | ● | — | |
| | | Pattern B | — | ● | ● |
| Pattern C | ● | — | ● | | |
| How to determine auto switch installation position At no pressure or low pressure, connect the auto switch to a power supply, and follow the directions. | | Step 1) Fully open the fingers.  | Step 1) Position fingers for gripping a workpiece.  | Step 1) Fully close the fingers.  | |
| | | Step 2) Insert the auto switch into the auto switch mounting groove from the direction of the arrow.  | | | |
| | | Step 3) Slide the auto switch in the direction of the arrow until the indicator light illuminates and fasten it at a position 0.3 to 0.5 mm in the direction of the arrow beyond the position where the indicator light illuminates. Position where light turns ON  Position to be secured  | Step 3) Slide the auto switch in the direction of the arrow until the indicator light illuminates.  | Step 4) Slide the auto switch further in the direction of the arrow until the indicator light goes out.  | |
| | | Step 5) Slide the auto switch in the opposite direction and fasten it at a position 0.3 to 0.5 mm beyond the position where the indicator light illuminates. Position where light turns ON  Position to be secured  | | | |

- * It is recommended that gripping a workpiece be performed close to the center of the finger stroke.
- * When holding a workpiece close at the end of opening/closing stroke of fingers, detecting performance of the combinations listed in the above table may be limited, depending on the hysteresis of an auto switch, etc.

MHL2 Series

Auto Switch Installation Examples and Mounting Positions

Various auto switch applications are possible through different combinations of auto switch quantities and detecting positions.

2) Detection when Gripping Interior of Workpiece

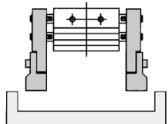
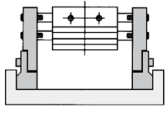
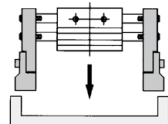
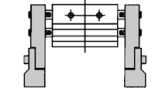
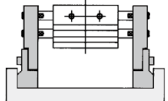
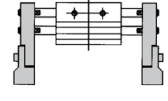
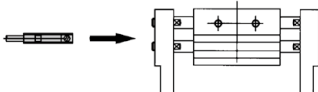
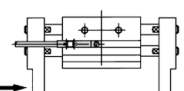
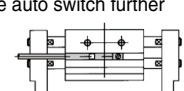
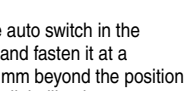
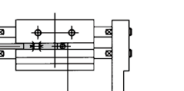
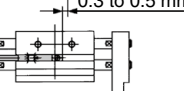
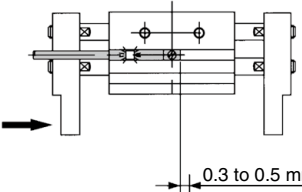
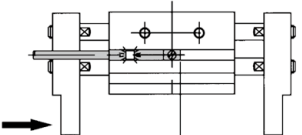
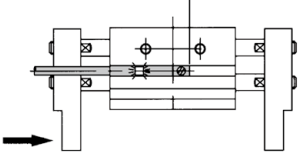
| Detection example | | ① Confirmation of fingers in reset position | ② Confirmation of workpiece held | ③ Confirmation of workpiece released |
|---|---|---|---|---|
| Position to be detected | | Position of fingers fully closed  | Position when gripping a workpiece  | Position of fingers fully open  |
| Operation of auto switch | | When fingers return: Auto switch to turn ON (Light ON) | When gripping a workpiece: Auto switch to turn ON (Light ON) | When a workpiece is not held (Abnormal operation): Auto switch to turn ON (Light ON) |
| Detection combinations | One auto switch * One position, any of ①, ② and ③ can be detected. | ● | ● | ● |
| | Two auto switches * Two positions of ①, ② and ③ can be detected. | Pattern A | ● | — |
| | | Pattern B | — | ● |
| Pattern C | ● | — | ● | |
| How to determine auto switch installation position | | Step 1) Fully close the fingers.  | Step 1) Position fingers for gripping a workpiece.  | Step 1) Fully open the fingers.  |
| At no pressure or low pressure, connect the auto switch to a power supply, and follow the directions. | | Step 2) Insert the auto switch into the auto switch mounting groove from the direction of the arrow.  | | |
| | | Step 3) Slide the auto switch in the direction of the arrow until the indicator light illuminates.  Step 4) Slide the auto switch further in the direction of the arrow until the indicator light goes out.  Step 5) Slide the auto switch in the opposite direction and fasten it at a position 0.3 to 0.5 mm beyond the position where the indicator light illuminates.  Position where light turns ON  Position to be secured  0.3 to 0.5 mm | Step 3) Slide the auto switch in the direction of the arrow until the indicator light illuminates and fasten it at a position 0.3 to 0.5 mm in the direction of the arrow beyond the position where the indicator light illuminates.  Position where light turns ON  0.3 to 0.5 mm Position to be secured  Position to be secured | |

- * It is recommended that gripping of a workpiece be performed close to the center of the finger stroke.
- When holding a workpiece close at the end of opening/closing stroke of fingers, detecting performance of the combinations listed in the above table may be limited, depending on the hysteresis of an auto switch, etc.

Auto Switch Hysteresis

The auto switch hysteresis is shown in the table. Refer to the table as a guide when setting auto switch positions.

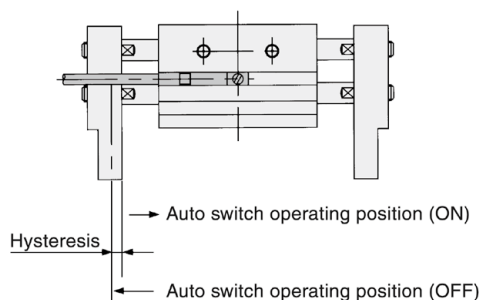

| Auto switch model | [mm] | |
|-------------------|----------|------------------------|
| | D-M9□(V) | D-M9□W(V) D-M9□A(V) |
| MHL2-10D□Z | 0.2 | |
| MHL2-16D□Z | 0.5 | |
| MHL2-20D□Z | 0.4 | |
| MHL2-25D□Z | 0.4 | |
| MHL2-32D□Z | 0.9 | |
| MHL2-40D□Z | 0.7 | |

Prior to Use

Auto Switch Connections and Examples

Sink Input Specifications

3-wire, NPN

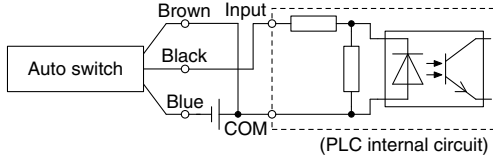

2-wire

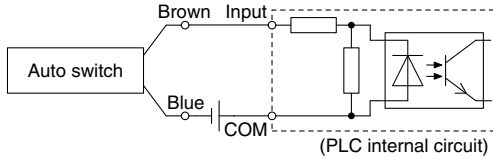

Source Input Specifications

3-wire, PNP

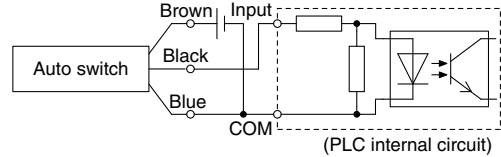

2-wire

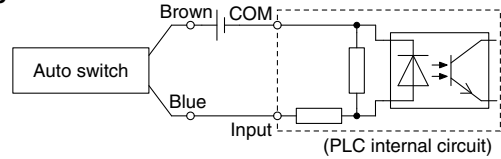

Connect according to the applicable PLC input specifications, as the connection method will vary depending on the PLC input specifications.

Examples of AND (Series) and OR (Parallel) Connections

* When using solid state auto switches, ensure the application is set up so the signals for the first 50 ms are invalid. Depending on the operating environment, the product may not operate properly.

3-wire AND connection for NPN output (Using relays)

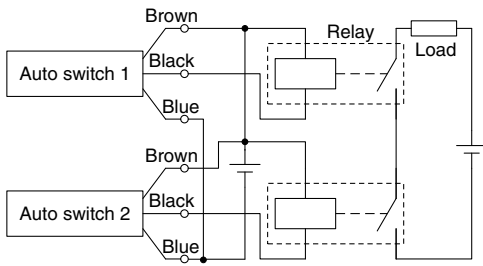

(Performed with auto switches only)

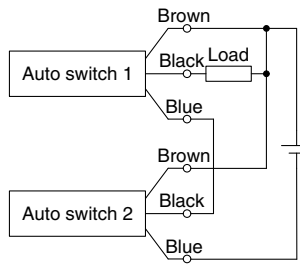

3-wire OR connection for NPN output

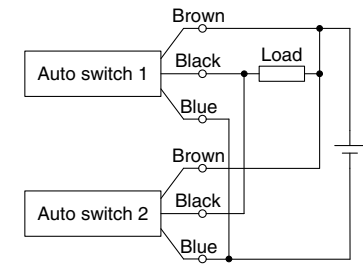

3-wire AND connection for PNP output (Using relays)

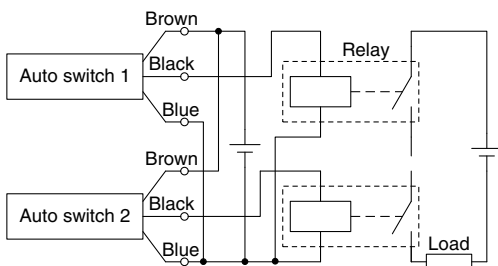

(Performed with auto switches only)

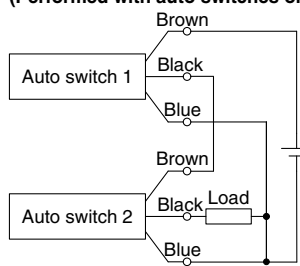

3-wire OR connection for PNP output

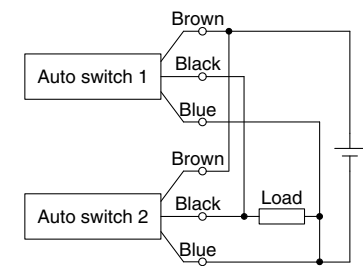

2-wire AND connection

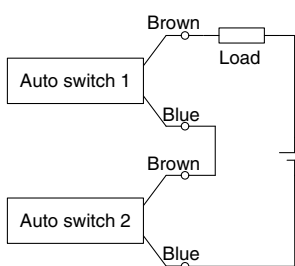

When two auto switches are connected in series, a load may malfunction because the load voltage will decline when in the ON state. The indicator lights will light up when both of the auto switches are in the ON state. Auto switches with a load voltage less than 20 V cannot be used.

$$\begin{aligned} \text{Load voltage at ON} &= \text{Power supply voltage} - \\ &\quad \text{Residual voltage} \times 2 \text{ pcs.} \\ &= 24 \text{ V} - 4 \text{ V} \times 2 \text{ pcs.} \\ &= 16 \text{ V} \end{aligned}$$

Example: Power supply is 24 VDC
Internal voltage drop in auto switch is 4 V.

2-wire OR connection

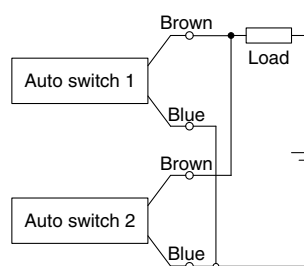

(Solid state)
When two auto switches are connected in parallel, malfunction may occur because the load voltage will increase when in the OFF state.

(Reed)
Because there is no current leakage, the load voltage will not increase when turned OFF. However, depending on the number of auto switches in the ON state, the indicator lights may sometimes grow dim or not light up, due to the dispersion and reduction of the current flowing to the auto switches.

$$\begin{aligned} \text{Load voltage at OFF} &= \text{Leakage current} \times 2 \text{ pcs.} \times \\ &\quad \text{Load impedance} \\ &= 1 \text{ mA} \times 2 \text{ pcs.} \times 3 \text{ k}\Omega \\ &= 6 \text{ V} \end{aligned}$$

Example: Load impedance is 3 k Ω .
Leakage current from auto switch is 1 mA.



| | | | |
|-----------|--------------|--|---------|
| 1 | -X4 | Heat Resistant (–10 to 100°C) | Page 18 |
| 2 | -X5 | Fluororubber Seal | Page 18 |
| 3 | -X28 | With Bolt for Adjusting the Closing Width | Page 19 |
| 4 | -X50 | Without Magnet | Page 19 |
| 5 | -X53 | Ethylene Propylene Rubber Seal (EPDM) | Page 19 |
| 6 | -X63 | Fluorine Grease | Page 20 |
| 7 | -X79 | Grease for Food Processing Machines: Fluorine Grease | Page 20 |
| 8 | -X79A | Grease for Food Processing Machines: Aluminum Complex Soap Base Grease | Page 21 |
| 9 | -X85 | Fine-particle Proof Specification (Lube-retainer) | Page 21 |
| 10 | -X86 | With Heavy Duty Scraper + Stable Lubrication Function (Lube-retainer) (Heavy Duty Scraper Material: NBR, Fluororubber) | Page 23 |

1 Heat Resistant (-10 to 100°C)

Symbol
-X4

Seal material and grease have been changed so that the product can be used at temperatures between -10 up to 100°C.

How to Order

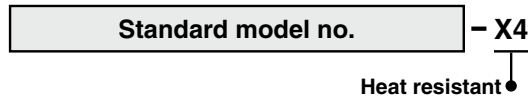

- * Magnet is built-in, but when using an auto switch, the acceptable temperature range becomes -10 to 60°C.
- * For lubrication, specialized grease GR-F is recommended.

Specifications

| | |
|--|------------------------------|
| Ambient temperature range | -10°C to 100°C (No freezing) |
| Seal material | Fluororubber |
| Grease | Heat-resistant grease (GR-F) |
| Specifications/dimensions other than the above | Same as the standard type |

Replacement Parts: Seal Kit

| |
|----------------------|
| Seal kit part number |
| MHL□□-PS-X4 |

- * Enter the cylinder bore size into □□ of the seal kit part number. Refer to page 7 for the replacement parts.
- * The seal kit does not include a grease pack. Order it separately.
Grease pack part number: GR-F-005 (5 g)

Warning
Precautions

Be aware that smoking cigarettes after your hands have come into contact with the grease used for this product can create a gas that is hazardous to humans.

2 Fluororubber Seal

Symbol
-X5

How to Order

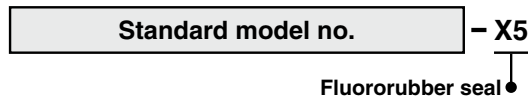

- * Please contact SMC, since the type of chemical and the operating temperature may not allow the use of this product.
- * Since the standard type magnet is built-in, please contact SMC for the product's adaptability to the operating environment.

Specifications

| | |
|--|---------------------------|
| Seal material | Fluororubber |
| Specifications/dimensions other than the above | Same as the standard type |

MHL2 Series

3 With Bolt for Adjusting the Closing Width Symbol -X28

Finger closing stroke can be fine-tuned by an adjustment bolt.

How to Order

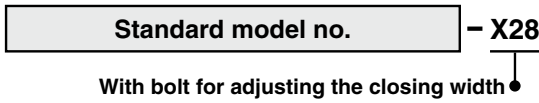

Specifications

| | |
|---|--------------------------------|
| Bore size [mm] | 10, 16, 20, 25, 32 |
| Adjustment range/ Adjustment bolt position | Refer to the dimensions below. |
| Specifications other than the above | Same as the standard type |
| Dimensions | Refer to the dimensions below. |

* Please contact SMC for ø40.
 * The bumper at the end of the adjustment bolt is not heat resistant. Combination with high temperature type is only available with a metal stopper.

Dimensions (The dimensions other than specified below are the same as the standard type.)

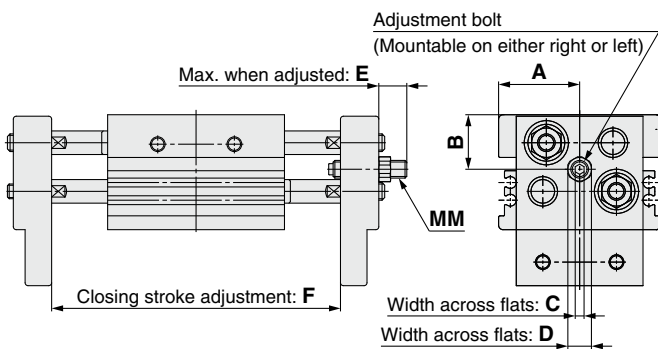

| Model | A | B | C | D | E | F | MM | |
|----------------|------|------|-----|----|------|-----------|------------|--|
| MHL2-10DZ-X28 | 22 | 15.5 | 2.5 | 7 | 4 | 2 | M5 x 0.8 | |
| MHL2-10D1Z-X28 | | | | | 11 | 16 | | |
| MHL2-10D2Z-X28 | 27.5 | 18.5 | 3 | 8 | 9.5 | 9 | M6 x 1 | |
| MHL2-16DZ-X28 | | | | | 13.5 | 20 | | |
| MHL2-16D1Z-X28 | | | | | 13.5 | 20 | | |
| MHL2-16D2Z-X28 | 32.5 | 21 | 4 | 12 | 7.5 | 7 | M8 x 1 | |
| MHL2-20DZ-X28 | | | | | 8.5 | 9 | | |
| MHL2-20D1Z-X28 | | | | | 8.5 | 9 | | |
| MHL2-20D2Z-X28 | | | | | 8.5 | 9 | | |
| MHL2-25DZ-X28 | 38 | 26 | 5 | 14 | 7.5 | 7 | M10 x 1 | |
| MHL2-25D1Z-X28 | | | | 15 | 18 | M10 x 1.5 | | |
| MHL2-25D2Z-X28 | 15 | 18 | | | | | | |
| MHL2-32DZ-X28 | 41 | 32 | 6 | 19 | 32.5 | 51 | M12 x 1.75 | |
| MHL2-32D1Z-X28 | | | | | 32.5 | | | |
| MHL2-32D2Z-X28 | | | | | 32.5 | | | |

4 Without Magnet Symbol -X50

How to Order

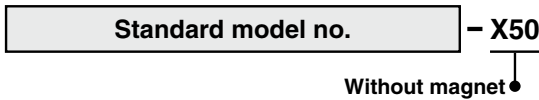

Specifications

| | |
|--|---------------------------|
| Magnet | None |
| Specifications/dimensions other than the above | Same as the standard type |

5 Ethylene Propylene Rubber Seal (EPDM) Symbol -X53

Seal material has been changed to ethylene propylene (EPDM), and grease to fluorine grease.

How to Order

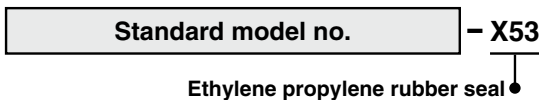

* For lubrication, specialized grease GR-F is recommended.
 Grease pack part number: GR-F-005 (5 g)

Specifications

| | |
|--|----------------------------------|
| Seal material | Ethylene propylene rubber (EPDM) |
| Grease | Fluorine grease (GR-F) |
| Specifications/dimensions other than the above | Same as the standard type |

Warning Precautions

Be aware that smoking cigarettes after your hands have come into contact with the grease used for this product can create a gas that is hazardous to humans.

6 Fluorine Grease **Symbol -X63**

How to Order

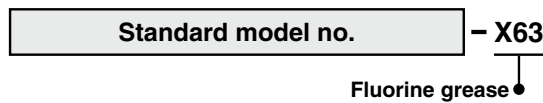

* For lubrication, specialized grease GR-F is recommended.
Grease pack part number: GR-F-005 (5 g)

Warning Precautions

Be aware that smoking cigarettes after your hands have come into contact with the grease used for this product can create a gas that is hazardous to humans.

Specifications

| | |
|--|---------------------------|
| Grease | Fluorine grease (GR-F) |
| Specifications/dimensions other than the above | Same as the standard type |

7 Grease for Food Processing Machines: Fluorine Grease **Symbol -X79**

Use grease for food processing machines (NSF-H1 certified/fluorine grease).

How to Order

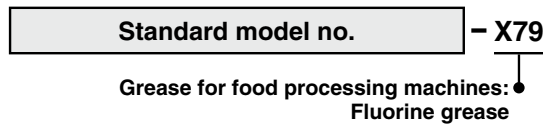

* For lubrication, specialized grease GR-H is recommended.
Grease pack part number: GR-H-010 (10 g)

Warning Precautions

Be aware that smoking cigarettes after your hands have come into contact with the grease used for this product can create a gas that is hazardous to humans.

Caution

Do not use air grippers in a food-related environment.

<Not installable>

Food zone Food may directly contact with air grippers, and is treated as food products.

<Installable>

Splash zone Food may directly contact with air grippers, but is not treated as food products.

Non-food zone Air grippers do not directly contact food.

Specifications

| | |
|--|--|
| Grease | Grease for food processing machines (NSF-H1 certified)/Fluorine grease |
| Specifications/dimensions other than the above | Same as the standard type |

* If the fluorine grease is not applicable to the working environment, use “-X79A.”

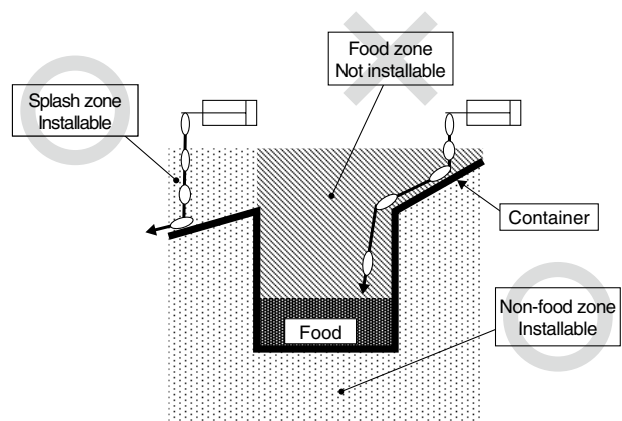

MHL2 Series

8 Grease for Food Processing Machines: Aluminum Complex Soap Base Grease Symbol -X79A

Use grease for food processing machines (NSF-H1 certified).

How to Order

Standard model no. - X79A

Grease for food processing machines: Aluminum complex soap base grease

* For lubrication, specialized grease GR-R is recommended.
Grease pack part number: GR-R-010 (10 g)

Specifications

| | |
|--|--|
| Grease | Grease for food processing machines (NSF-H1 certified)/Aluminum complex soap base grease |
| Specifications/dimensions other than the above | Same as the standard type |

Caution

Do not use air grippers in a food-related environment.

<Not installable>

Food zone..... Food may directly contact with air grippers, and is treated as food products.

<Installable>

Splash zone..... Food may directly contact with air grippers, but is not treated as food products.

Non-food zone Air grippers do not directly contact food.

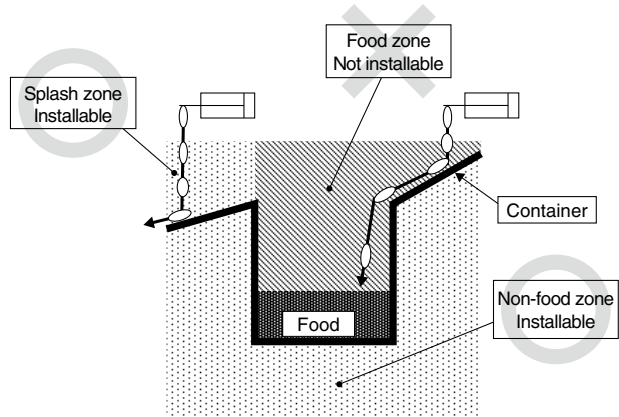

9 Fine-particle Proof Specification (Lube-retainer) Symbol -X85

Applicable for environments with flying micro-powder (10 to 100 μm) such as ceramic powder, toner powder, paper powder, and metallic powder (excluding weld spatter)

A grease film is formed on the rod by the Lube-retainer which maintains lubrication for longer increasing gripper endurance.

How to Order

Standard model no. - X85

Fine-particle proof specification

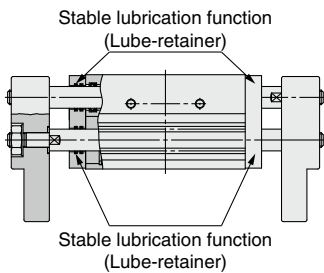

Specifications

| | | | | | | |
|---|--|----|------------|-----|-----|-----|
| Bore size [mm] | 10 | 16 | 20 | 25 | 32 | 40 |
| Dust prevention method | Stable lubrication function (Lube-retainer) type (8 locations) | | | | | |
| Operating pressure [MPa] | 0.4 to 0.6 | | 0.3 to 0.6 | | | |
| Repeatability | ±0.1 | | | | | |
| Effective gripping force [N] ^{*1} at 0.5 MPa | 14 | 45 | 74 | 131 | 228 | 396 |

*1 Gripping point distance: 40 mm

| | |
|-------------------------------------|-------------------------------------|
| Specifications other than the above | Same as the standard type |
| Dimensions | Refer to the dimensions on page 23. |

Gripping Point

- The workpiece gripping point distance should be within the gripping force ranges given for each pressure in the effective gripping force graphs on the next page.
- If operated with the workpiece gripping point beyond the indicated ranges, the load that will be applied to the fingers or the guide will become excessively unbalanced. As a result, the fingers could become loosened and adversely affect the service life of the unit.

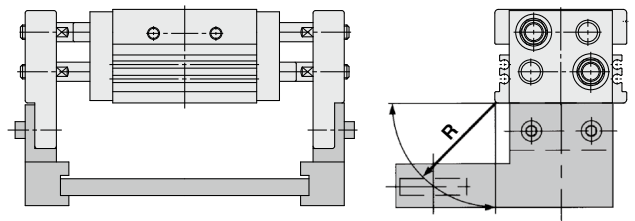

R: Gripping point distance [mm]

9 Fine-particle Proof Specification (Lube-retainer)

Effective Gripping Force

● **Indication of effective gripping force**

The gripping force shown in the tables represents the gripping force of one finger when all fingers and attachments are in contact with the workpiece.

F = One finger thrust

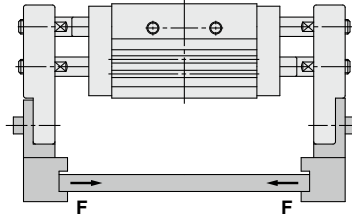

MHL2-10DZ-X85

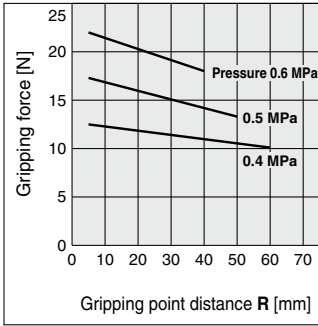

MHL2-10D₂Z-X85

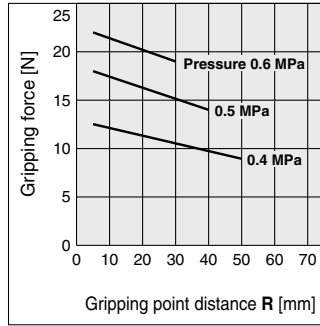

MHL2-16DZ-X85

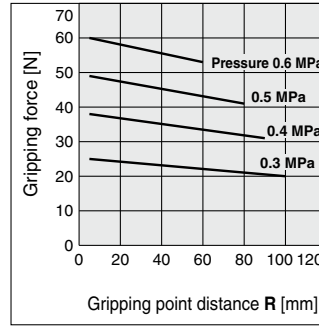

MHL2-16D₂Z-X85

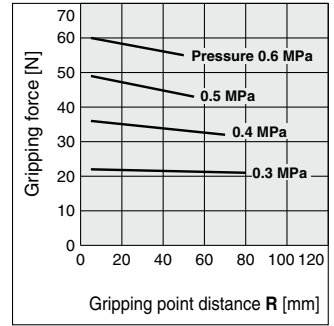

MHL2-20DZ-X85

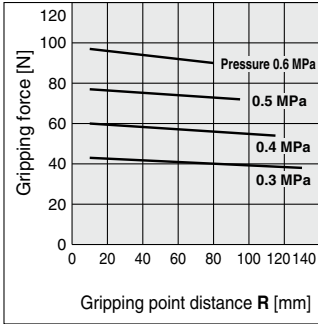

MHL2-20D₂Z-X85

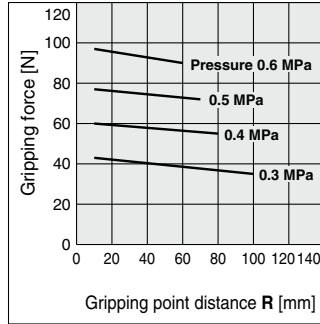

MHL2-25DZ-X85

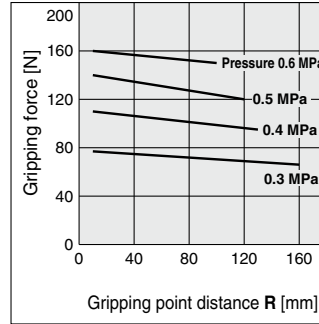

MHL2-25D₂Z-X85

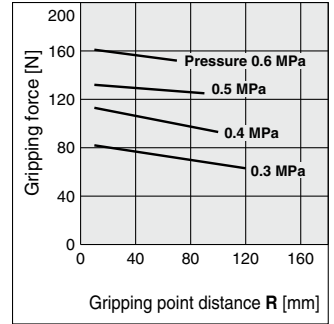

MHL2-32DZ-X85

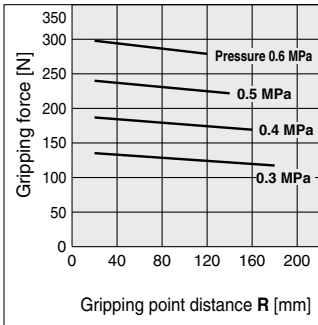

MHL2-32D₂Z-X85

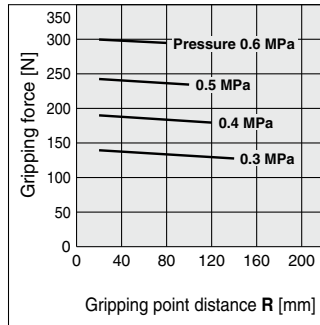

MHL2-40DZ-X85

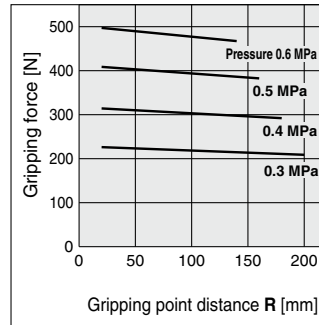

MHL2-40D₂Z-X85

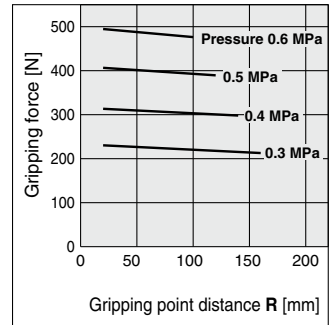

MHL2 Series

9 Fine-particle Proof Specification (Lube-retainer) Symbol **-X85**

Dimensions (The dimensions other than specified below are the same as the standard type.)

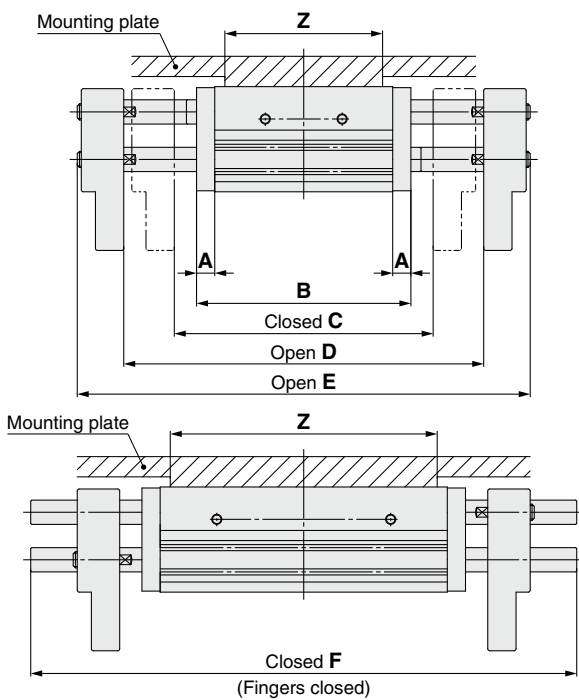

| Model | A | B | C | D | E | F | Z | Weight [g] |
|----------------|------|-----|-----|-----|-----|-----|-----|------------|
| MHL2-10DZ-X85 | 8 | 67 | 88 | 108 | 132 | 112 | 49 | 350 |
| MHL2-10D1Z-X85 | 8 | 83 | 104 | 144 | 168 | 131 | 65 | 420 |
| MHL2-10D2Z-X85 | 8 | 101 | 122 | 182 | 206 | 169 | 83 | 495 |
| MHL2-16DZ-X85 | 9.5 | 79 | 96 | 126 | 156 | 126 | 58 | 650 |
| MHL2-16D1Z-X85 | 9.5 | 109 | 126 | 186 | 216 | 179 | 88 | 840 |
| MHL2-16D2Z-X85 | 9.5 | 129 | 146 | 226 | 256 | 219 | 108 | 965 |
| MHL2-20DZ-X85 | 9 | 89 | 108 | 148 | 186 | 146 | 69 | 1115 |
| MHL2-20D1Z-X85 | 9 | 131 | 150 | 230 | 268 | 221 | 111 | 1490 |
| MHL2-20D2Z-X85 | 9 | 151 | 170 | 270 | 308 | 261 | 131 | 1675 |
| MHL2-25DZ-X85 | 9 | 106 | 128 | 178 | 224 | 174 | 86 | 1815 |
| MHL2-25D1Z-X85 | 9 | 160 | 182 | 282 | 328 | 270 | 140 | 2500 |
| MHL2-25D2Z-X85 | 9 | 178 | 200 | 320 | 366 | 308 | 158 | 2730 |
| MHL2-32DZ-X85 | 11.5 | 133 | 161 | 231 | 283 | 213 | 108 | 3255 |
| MHL2-32D1Z-X85 | 11.5 | 181 | 209 | 329 | 381 | 311 | 156 | 4145 |
| MHL2-32D2Z-X85 | 11.5 | 225 | 253 | 413 | 465 | 395 | 200 | 4960 |
| MHL2-40DZ-X85 | 10 | 168 | 198 | 298 | 358 | 278 | 146 | 5685 |
| MHL2-40D1Z-X85 | 10 | 226 | 256 | 416 | 476 | 396 | 204 | 7220 |
| MHL2-40D2Z-X85 | 10 | 266 | 296 | 496 | 556 | 476 | 244 | 8270 |

* The customer's mounting plate should be attached with the Z-dimension.

10 With Heavy Duty Scraper + Stable Lubrication Function (Lube-retainer) (Heavy Duty Scraper Material: NBR, Fluororubber) Symbol **-X86**

- The cylinders are suitable for use in environments with significant amounts of dust with the heavy duty scraper on the wiper ring. In addition, the Lube-retainer creates a grease coating around the rod, which improves lubrication.
- Heavy duty scraper material can be NBR or fluororubber.

How to Order

Standard model no. **- X86**

With heavy duty scraper (NBR) + Stable lubrication function

Standard model no. **- X86A**

With heavy duty scraper (Fluororubber) + Stable lubrication function

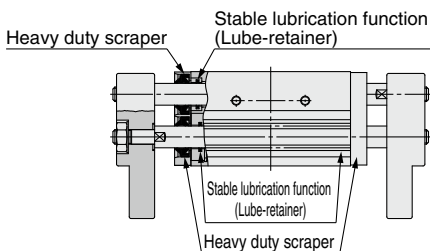

Specifications

| Symbol | -X86 | | | -X86A | | |
|---|---|-----|-----|--------------|-----|-----|
| | Bore size [mm] | 25 | 32 | 40 | 25 | 32 |
| Dust prevention method | Heavy duty scraper + Stable lubrication function (Lube-retainer) type (8 locations) | | | | | |
| Heavy duty scraper material | NBR | | | Fluororubber | | |
| Operating pressure [MPa] | 0.3 to 0.6 | | | | | |
| Repeatability | ±0.1 | | | | | |
| Effective gripping force [N]*1 at 0.5 MPa | 131 | 228 | 396 | 131 | 228 | 396 |

*1 Gripping point distance: 40 mm

* For water resistant type, please contact SMC local sales representative.

| | |
|-------------------------------------|-------------------------------------|
| Specifications other than the above | Same as the standard type |
| Dimensions | Refer to the dimensions on page 24. |

10 With Heavy Duty Scraper + Stable Lubrication Function (Lube-retainer) (Heavy Duty Scraper Material: NBR, Fluororubber)

Symbol
-X86 □

Effective Gripping Force

● **Indication of effective gripping force**

The gripping force shown in the tables represents the gripping force of one finger when all fingers and attachments are in contact with the workpiece.

F = One finger thrust

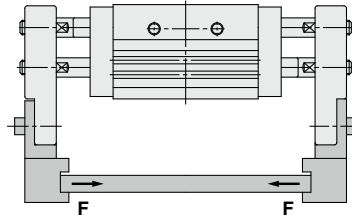

MHL2-25DZ-X86/X86A

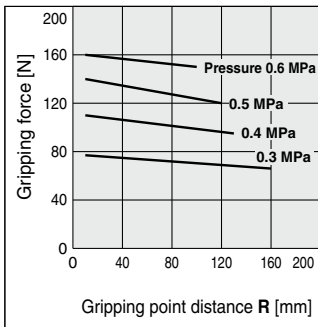

MHL2-25D¹/₂Z-X86/X86A

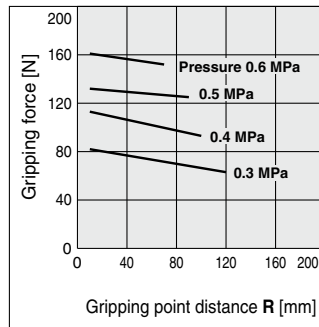

MHL2-32DZ-X86/X86A

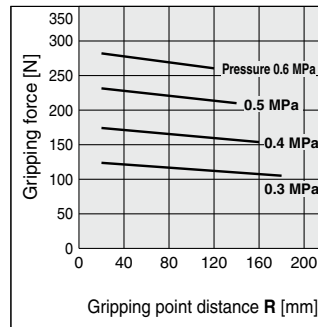

MHL2-32D¹/₂Z-X86/X86A

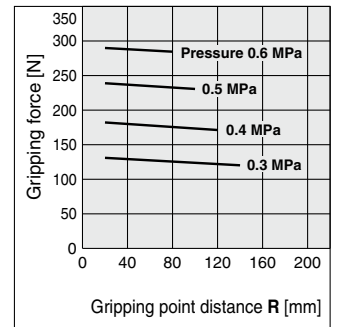

MHL2-40DZ-X86/X86A

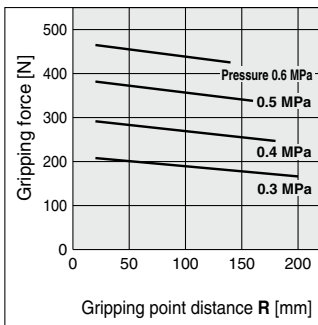

MHL2-40D¹/₂Z-X86/X86A

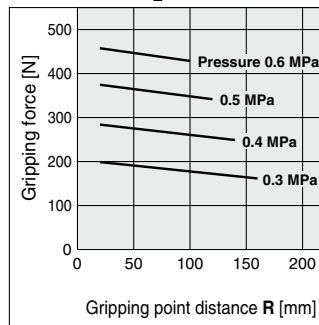

Dimensions (The dimensions other than specified below are the same as the standard type.)

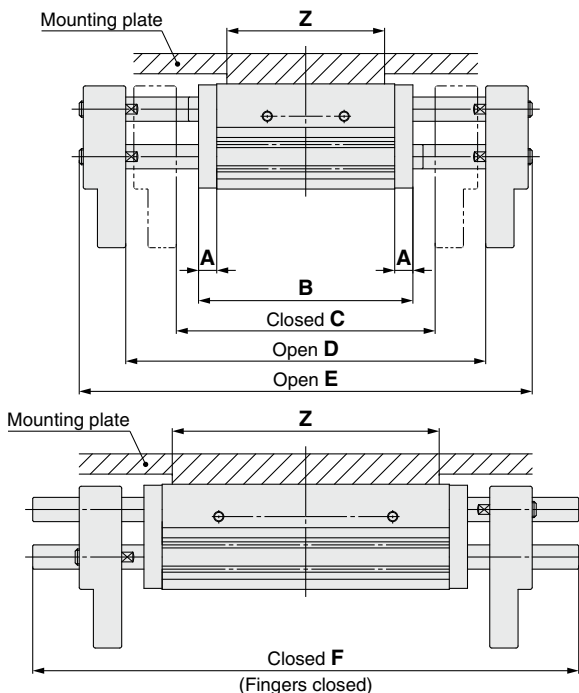

| Model | A | B | C | D | E | F | Z | Weight [g] |
|---|------|-----|-----|-----|-----|-----|-----|------------|
| MHL2-25DZ-X86(A) | 9 | 106 | 128 | 178 | 224 | 174 | 86 | 1835 |
| MHL2-25D ¹ / ₂ Z-X86(A) | 9 | 160 | 182 | 282 | 328 | 270 | 140 | 2520 |
| MHL2-25D2Z-X86(A) | 9 | 178 | 200 | 320 | 366 | 308 | 158 | 2750 |
| MHL2-32DZ-X86(A) | 11.5 | 133 | 161 | 231 | 283 | 213 | 108 | 3250 |
| MHL2-32D ¹ / ₂ Z-X86(A) | 11.5 | 181 | 209 | 329 | 381 | 311 | 156 | 4150 |
| MHL2-32D2Z-X86(A) | 11.5 | 225 | 253 | 413 | 465 | 395 | 200 | 4960 |
| MHL2-40DZ-X86(A) | 10 | 168 | 198 | 298 | 358 | 278 | 146 | 5765 |
| MHL2-40D ¹ / ₂ Z-X86(A) | 10 | 226 | 256 | 416 | 476 | 396 | 204 | 7295 |
| MHL2-40D2Z-X86(A) | 10 | 266 | 296 | 496 | 556 | 476 | 244 | 8340 |

* The customer's mounting plate should be attached with the Z-dimension.



MHL2 Series

Specific Product Precautions

Be sure to read this before handling the products. Refer to the back cover for safety instructions. For air gripper and auto switch precautions, refer to the “Handling Precautions for SMC Products” and the “Operation Manual” on the SMC website: <https://www.smcworld.com>

Design

Warning

If a workpiece is hooked onto the attachment, make sure that excessive impact will not be created at the start and the end of the movement. Failure to observe this precaution may result in shifting or dropping the workpiece, which could be dangerous.

How to Mount Air Grippers

Possible to mount from 2 directions

Axial Mounting

• Body tapped

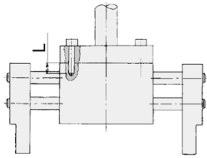

| Model | Applicable bolt | Max. tightening torque [N·m] | Max. screw-in depth L [mm] |
|------------|-----------------|------------------------------|----------------------------|
| MHL2-10D□Z | M4 x 0.7 | 2.1 | 8 |
| MHL2-16D□Z | M5 x 0.8 | 4.3 | 10 |
| MHL2-20D□Z | M6 x 1 | 7.3 | 12 |
| MHL2-25D□Z | M8 x 1.25 | 17.7 | 16 |
| MHL2-32D□Z | M8 x 1.25 | 18 | 16 |
| MHL2-40D□Z | M10 x 1.5 | 36 | 20 |

• Body through-hole

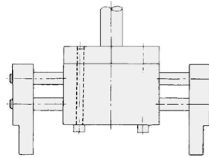

| Model | Applicable bolt | Max. tightening torque [N·m] |
|------------|-----------------|------------------------------|
| MHL2-10D□Z | M4 x 0.7 | 2.1 |
| MHL2-16D□Z | M5 x 0.8 | 4.3 |
| MHL2-20D□Z | M6 x 1 | 7.3 |
| MHL2-25D□Z | M8 x 1.25 | 17.7 |

Lateral Mounting

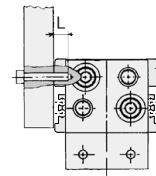

| Model | Applicable bolt | Max. tightening torque [N·m] | Max. screw-in depth L [mm] |
|------------|-----------------|------------------------------|----------------------------|
| MHL2-10D□Z | M4 x 0.7 | 1.4 | 5 |
| MHL2-16D□Z | M5 x 0.8 | 2.8 | 7 |
| MHL2-20D□Z | M6 x 1 | 4.8 | 7 |
| MHL2-25D□Z | M8 x 1.25 | 12.0 | 7 |
| MHL2-32D□Z | M8 x 1.25 | 12.0 | 11 |
| MHL2-40D□Z | M10 x 1.5 | 24.0 | 12 |

How to Mount Attachments to the Finger

1. Make sure that the piston rod is retracted so as to avoid twisting the piston rod when mounting an attachment to the finger.
2. Do not scratch or dent the sliding parts of the piston rod. Damage to the bearings or seals may cause air leaks or faulty operation.
3. Refer to the table on the right for the proper tightening torque on the bolt used for securing the attachment to the finger.

| Model | Applicable bolt | Max. tightening torque [N·m] |
|------------|-----------------|------------------------------|
| MHL2-10D□Z | M4 x 0.7 | 1.4 |
| MHL2-16D□Z | M5 x 0.8 | 2.8 |
| MHL2-20D□Z | M6 x 1 | 4.8 |
| MHL2-25D□Z | M8 x 1.25 | 12.0 |
| MHL2-32D□Z | M10 x 1.5 | 24.0 |
| MHL2-40D□Z | M12 x 1.75 | 42.2 |

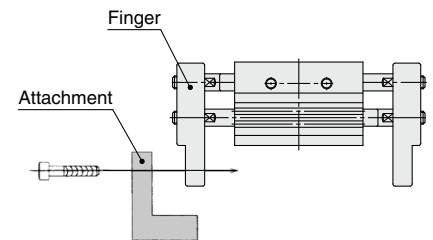

Safety Instructions

These safety instructions are intended to prevent hazardous situations and/or equipment damage. These instructions indicate the level of potential hazard with the labels of “**Caution**,” “**Warning**” or “**Danger**.” They are all important notes for safety and must be followed in addition to International Standards (ISO/IEC)*1), and other safety regulations.

 **Caution:** **Caution** indicates a hazard with a low level of risk which, if not avoided, could result in minor or moderate injury.

 **Warning:** **Warning** indicates a hazard with a medium level of risk which, if not avoided, could result in death or serious injury.

 **Danger :** **Danger** indicates a hazard with a high level of risk which, if not avoided, will result in death or serious injury.

*1) ISO 4414: Pneumatic fluid power – General rules relating to systems.
ISO 4413: Hydraulic fluid power – General rules relating to systems.
IEC 60204-1: Safety of machinery – Electrical equipment of machines.
(Part 1: General requirements)
ISO 10218-1: Manipulating industrial robots – Safety.
etc.

Warning

1. The compatibility of the product is the responsibility of the person who designs the equipment or decides its specifications.

Since the product specified here is used under various operating conditions, its compatibility with specific equipment must be decided by the person who designs the equipment or decides its specifications based on necessary analysis and test results. The expected performance and safety assurance of the equipment will be the responsibility of the person who has determined its compatibility with the product. This person should also continuously review all specifications of the product referring to its latest catalog information, with a view to giving due consideration to any possibility of equipment failure when configuring the equipment.

2. Only personnel with appropriate training should operate machinery and equipment.

The product specified here may become unsafe if handled incorrectly. The assembly, operation and maintenance of machines or equipment including our products must be performed by an operator who is appropriately trained and experienced.

3. Do not service or attempt to remove product and machinery/equipment until safety is confirmed.

1. The inspection and maintenance of machinery/equipment should only be performed after measures to prevent falling or runaway of the driven objects have been confirmed.
2. When the product is to be removed, confirm that the safety measures as mentioned above are implemented and the power from any appropriate source is cut, and read and understand the specific product precautions of all relevant products carefully.
3. Before machinery/equipment is restarted, take measures to prevent unexpected operation and malfunction.

4. Contact SMC beforehand and take special consideration of safety measures if the product is to be used in any of the following conditions.

1. Conditions and environments outside of the given specifications, or use outdoors or in a place exposed to direct sunlight.
2. Installation on equipment in conjunction with atomic energy, railways, air navigation, space, shipping, vehicles, military, medical treatment, combustion and recreation, or equipment in contact with food and beverages, emergency stop circuits, clutch and brake circuits in press applications, safety equipment or other applications unsuitable for the standard specifications described in the product catalog.
3. An application which could have negative effects on people, property, or animals requiring special safety analysis.
4. Use in an interlock circuit, which requires the provision of double interlock for possible failure by using a mechanical protective function, and periodical checks to confirm proper operation.

Caution

1. The product is provided for use in manufacturing industries.

The product herein described is basically provided for peaceful use in manufacturing industries.
If considering using the product in other industries, consult SMC beforehand and exchange specifications or a contract if necessary.
If anything is unclear, contact your nearest sales branch.

Limited warranty and Disclaimer/ Compliance Requirements

The product used is subject to the following “Limited warranty and Disclaimer” and “Compliance Requirements”.

Read and accept them before using the product.

Limited warranty and Disclaimer

1. The warranty period of the product is 1 year in service or 1.5 years after the product is delivered, whichever is first.*2)
Also, the product may have specified durability, running distance or replacement parts. Please consult your nearest sales branch.
2. For any failure or damage reported within the warranty period which is clearly our responsibility, a replacement product or necessary parts will be provided.
This limited warranty applies only to our product independently, and not to any other damage incurred due to the failure of the product.
3. Prior to using SMC products, please read and understand the warranty terms and disclaimers noted in the specified catalog for the particular products.

*2) Vacuum pads are excluded from this 1 year warranty.

A vacuum pad is a consumable part, so it is warranted for a year after it is delivered.
Also, even within the warranty period, the wear of a product due to the use of the vacuum pad or failure due to the deterioration of rubber material are not covered by the limited warranty.

Compliance Requirements

1. The use of SMC products with production equipment for the manufacture of weapons of mass destruction (WMD) or any other weapon is strictly prohibited.
2. The exports of SMC products or technology from one country to another are governed by the relevant security laws and regulations of the countries involved in the transaction. Prior to the shipment of a SMC product to another country, assure that all local rules governing that export are known and followed.

Caution

SMC products are not intended for use as instruments for legal metrology.

Measurement instruments that SMC manufactures or sells have not been qualified by type approval tests relevant to the metrology (measurement) laws of each country. Therefore, SMC products cannot be used for business or certification ordained by the metrology (measurement) laws of each country.

Revision History

Edition B * Bore sizes 32 and 40 mm have been added.
* Number of pages has been increased from 24 to 28.

XR

Safety Instructions

Be sure to read the “Handling Precautions for SMC Products” (M-E03-3) and “Operation Manual” before use.