

# Multi Hand Adapter

New

RoHS

Multi hand adapter

Allows for the handling of various workpieces by a single robot

Allows for the simultaneous transfer of multiple workpieces

- Up to 3 grippers can be mounted.
- Reduces tool changing time



Robot arm end standards:  
Equivalent to ISO9409-1-50-4-M6

Mounting and removal are possible using the 2 clamber bolts.

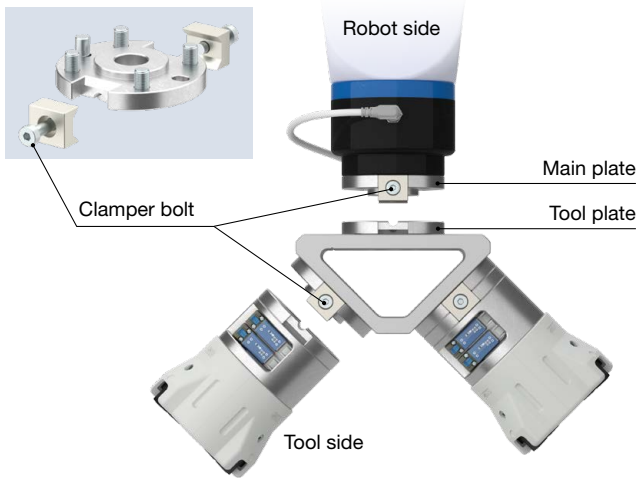

## 3 gripper mounting angles

90° type

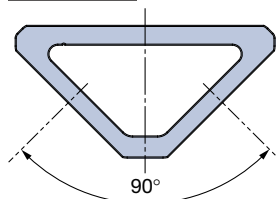

120° type

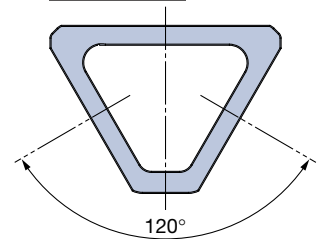

180° type p. 6

Combination of two 90° type adapters

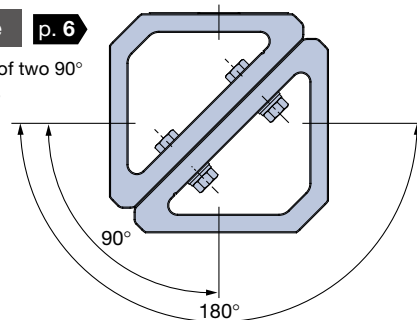

## Gripper Mounting Example

A wide range of combinations is possible. Mounting angles can be selected according to the specifications.

90° type

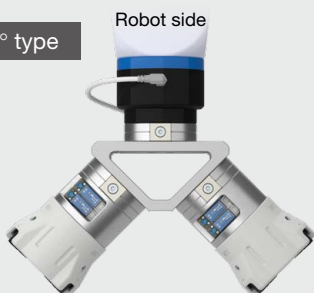

Robot side

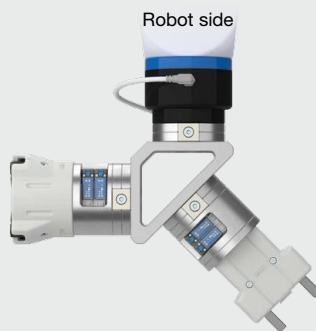

180° type  
(90° type x 2 units)

Robot side

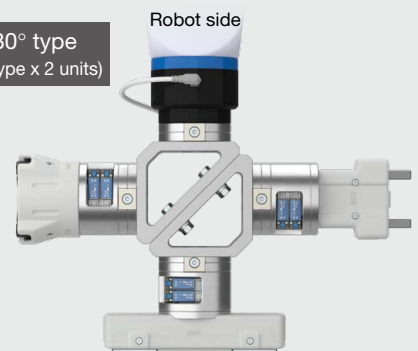

**RMMA Series**



CAT.ES160-11A

# Multi Hand Adapter RMMA Series

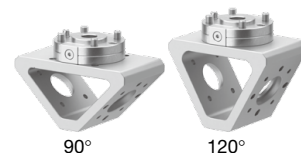

## How to Order

RMMA1 - 20 T **090** - **E** - **□**

①
②
③

### ① Gripper mounting angle

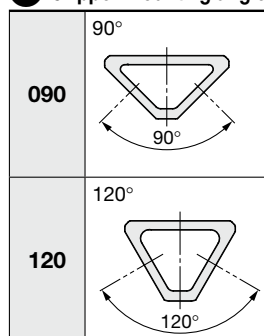

### ② Changer specification

E	With main plate and tool plate	
F	With tool plate	
N	Without tool plate	

\* E and F are equipped with a collar assembly.

### ③ Option

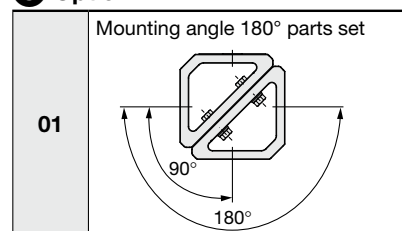

\* RMMA1-20T090-E-01 is the set part number, which includes an RMMA1-20T090-E multi-hand adapter (90° mounting angle) and an RMMA-A11-01 (option replacement parts). For details, refer to page 6.



\* For the connector cable to be used when two or more grippers are mounted, refer to page 8.

\* This product is shipped as parts (in an unassembled state). Therefore, the user needs to assemble them into the product.

## Specifications

Mounting angle		90°	120°
<b>Max. work load</b>		20 kg*1	
<b>Moment resistance Mp, Mr</b>		60 N·m*1	
<b>Torque resistance My</b>		60 N·m*1	
<b>Standards</b>	Robot side	Equivalent to ISO9409-1-50-4-M6	
	Gripper mounting side	Equivalent to ISO9409-1-50-4-M6	
<b>Operating temperature</b>		-10 to 60°C*1	

\*1 Use the product at the minimum tolerances of the robot and peripheral devices to be connected.  
In addition, be sure to perform a verification test to confirm the absence of problems before use.

### Weight

Item	[g]	
	Mounting angle 90°	Mounting angle 120°
With main plate and tool plate	420*2	550*2
With tool plate	400*2	430*2
Without tool plate	340	370

\*2 The weight of the M6 x 10 hexagon socket thin head cap screws (4 pcs.) and the ø6 x 10 parallel pin (1 pc.) is included in the weight.

\* The weight of the multi-hand adapter body is included in the weights above.

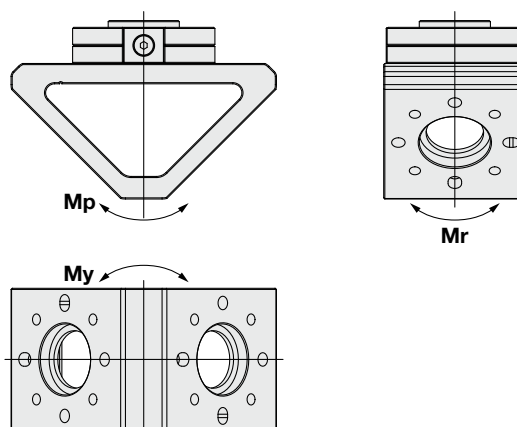

## ⚠ Specific Product Precautions

**Be sure to read this before handling the products. Refer to the back cover for safety instructions.**  
**For air gripper precautions, refer to the "Handling Precautions for SMC Products" and the "Operation Manual" on the SMC website: <https://www.smcworld.com>**



## Component Parts

### ■ Main plate (for mounting the robot)

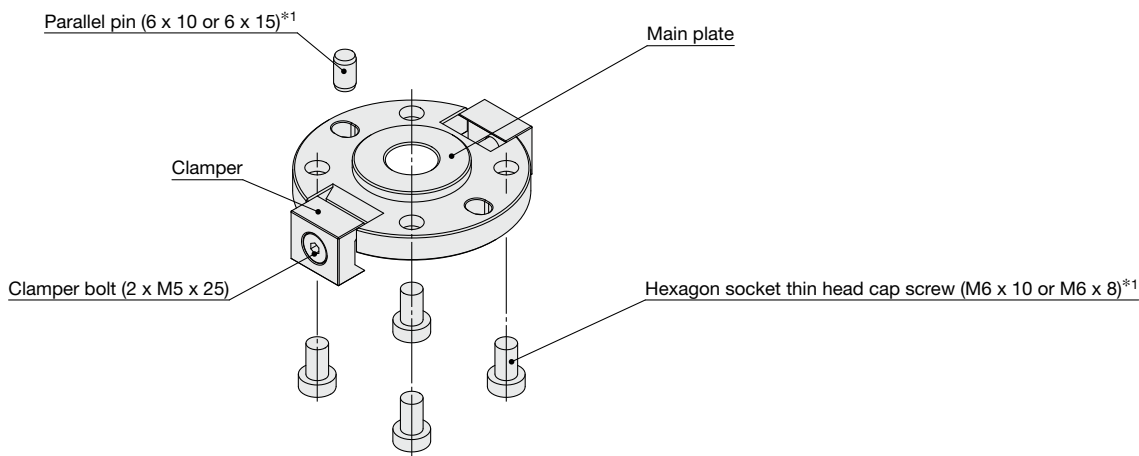

### ■ Tool plate

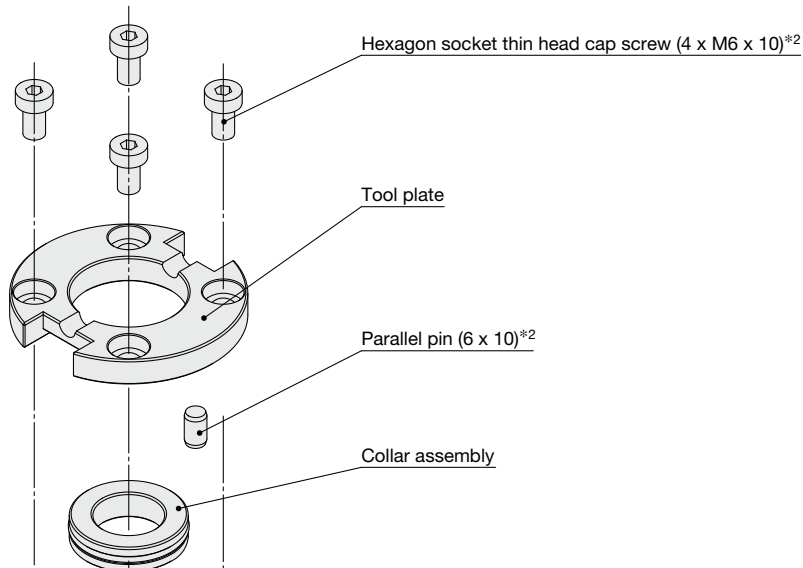

### ■ Multi Hand Adapter

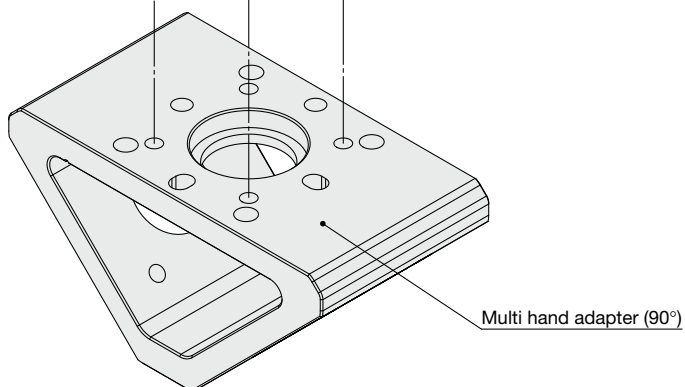

### Replacement Parts

No.	Description	Replacement part no.	Quantity
1	<b>Main plate</b>	RMTM2-4M1*1	1
2	<b>Tool plate</b>	RMTM2-4T1*2	1
3	<b>Collar assembly</b>	RMMA-A00-01	1

\*1 Two types of main plate mounting bolts and two types of parallel pins, with different lengths, are supplied with the product. Select parts that suit the robot in use.

\*2 The tool plate includes the following accessories.  
Hexagon socket thin head cap screw (4 pcs.) and parallel pin  $\phi 6 \times 10$  (1 pc.)

# RMMA Series

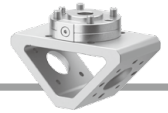

## Dimensions: Mounting Angle 90°

### RMMA1-20T090-E: With main plate and tool plate (E)

\* The dimensions of the model with tool plate (F) are the same as those of the model with main plate/tool plate (E) except for the detailed portions.

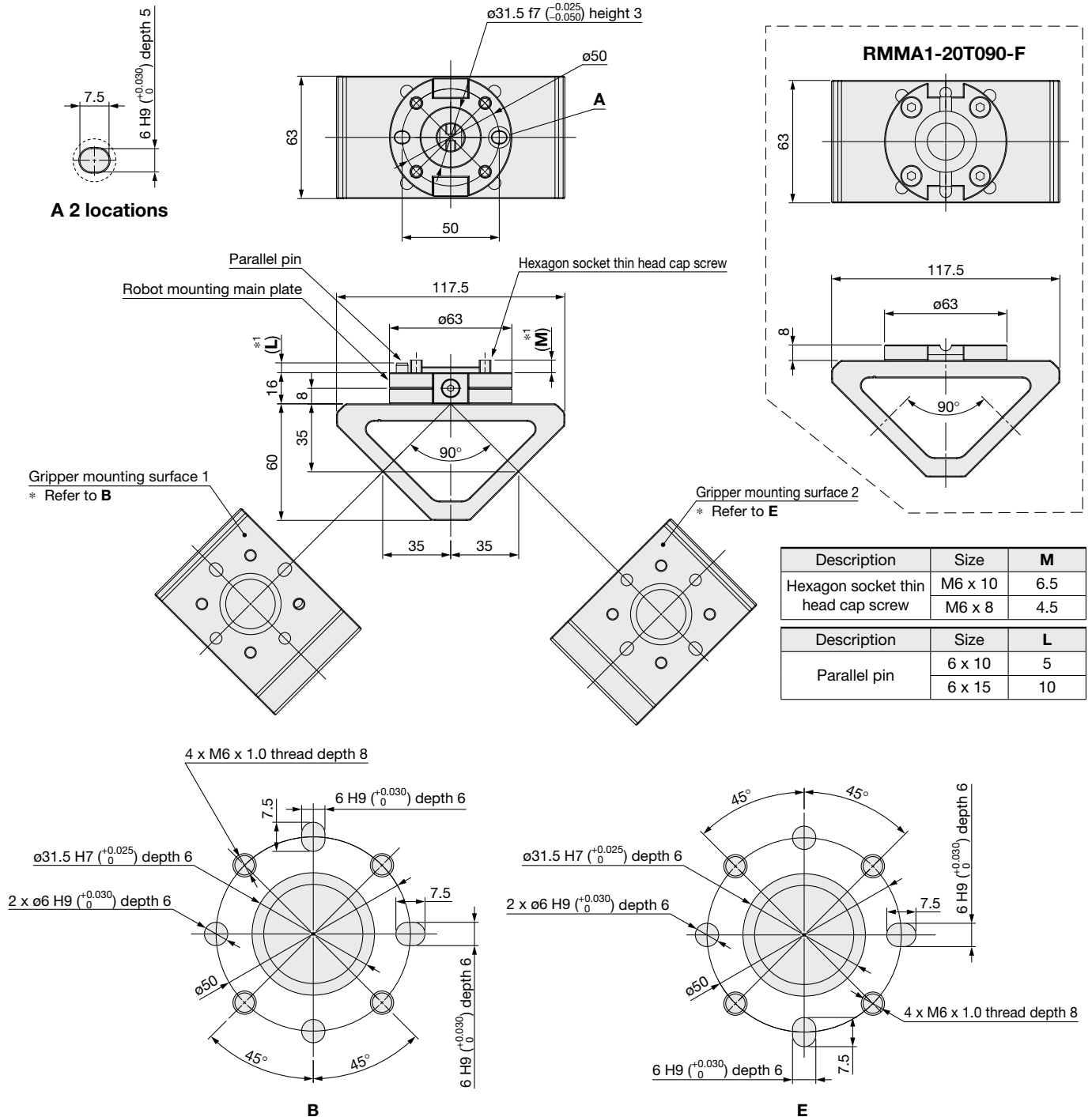

\*1 Two types of main plate mounting bolts and two types of parallel pins, with different lengths, are supplied with the product. Select parts that suit the robot in use.

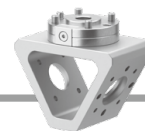

## Dimensions: Mounting Angle 120°

### RMMA1-20T120-E: With main plate and tool plate (E)

\* The dimensions of the model with tool plate (F) are the same as those of the model with main plate/tool plate (E) except for the detailed portions.

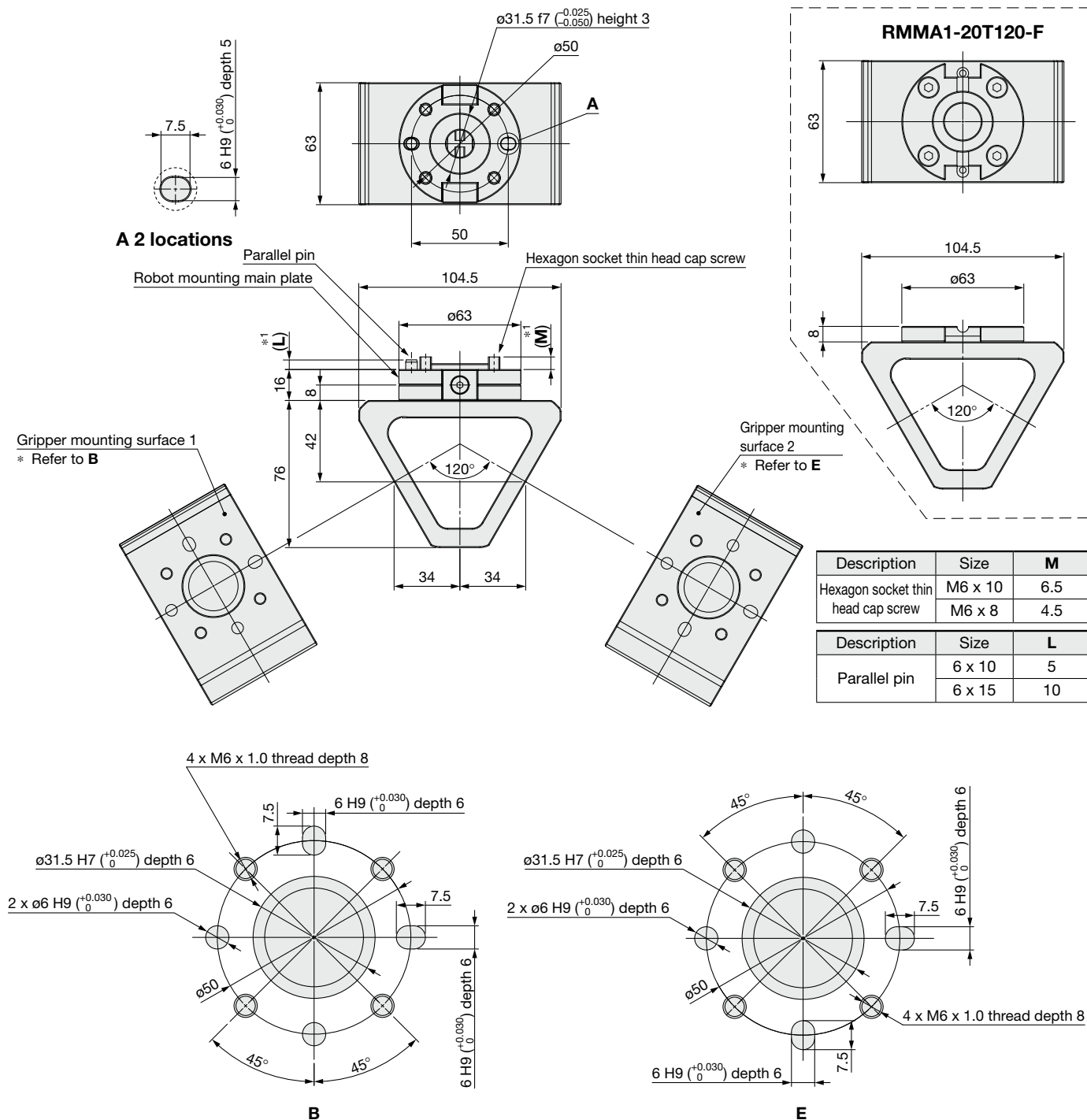

\*1 Two types of main plate mounting bolts and two types of parallel pins, with different lengths, are supplied with the product. Select parts that suit the robot in use.

# RMMA Series

## Dimensions: Multi Hand Adapter Single Unit (90°/120° mounting angle)

### RMMA1-20T090-N: Mounting Angle 90°

### RMMA1-20T120-N: Mounting Angle 120°

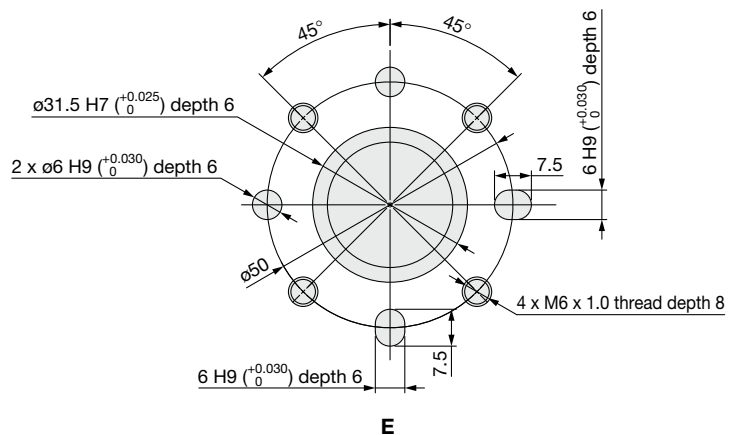
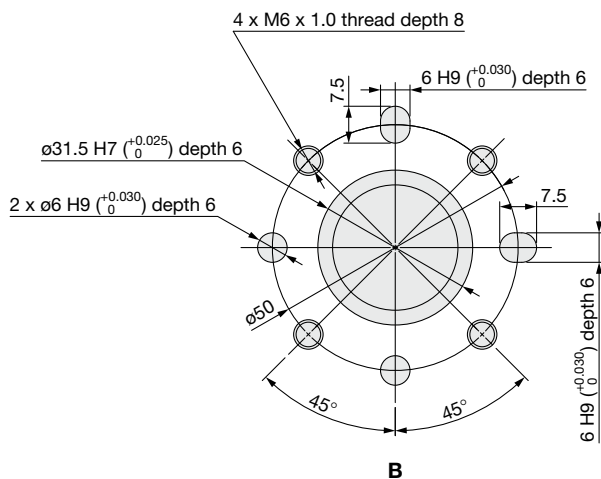
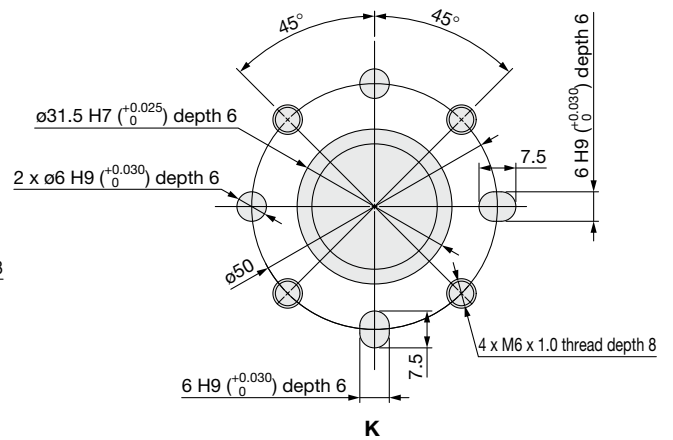
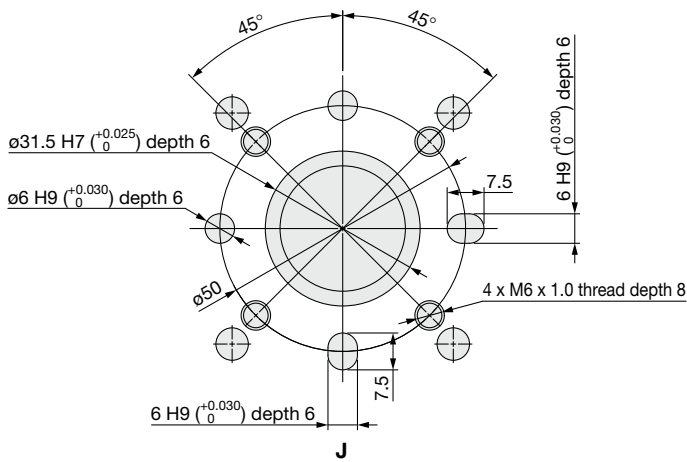
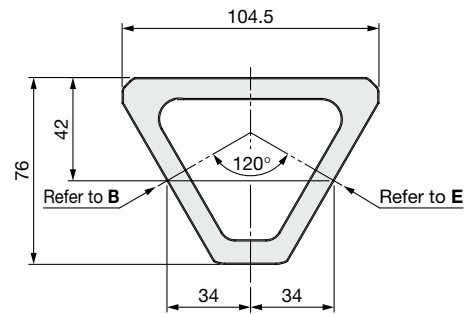
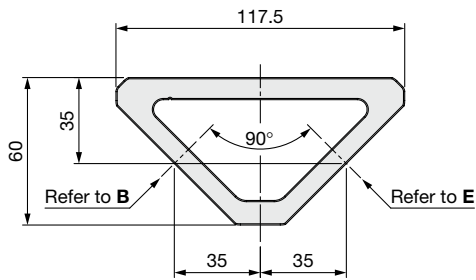
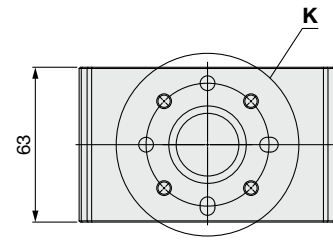
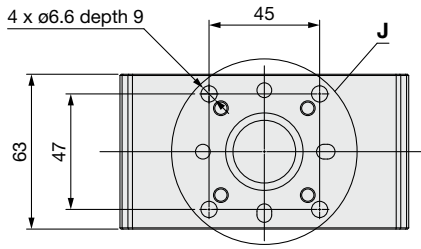



# RMMA Series Option

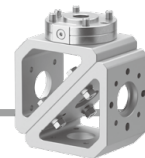

Mounting example

## Mounting Angle 180° Parts Set/RMMA1-20T090-E-01

- \* RMMA1-20T090-E-01 (180° mounting angle) is the set part number, which includes an RMMA1-20T090-E multi-hand adapter (90° mounting angle) and an RMMA-A11-01 (option replacement parts).
- \* Only an additional 90° mounting angle can be used in combination.

Weight: 919 g (RMMA1-20T090-E-01)

### RMMA1-20T090-E

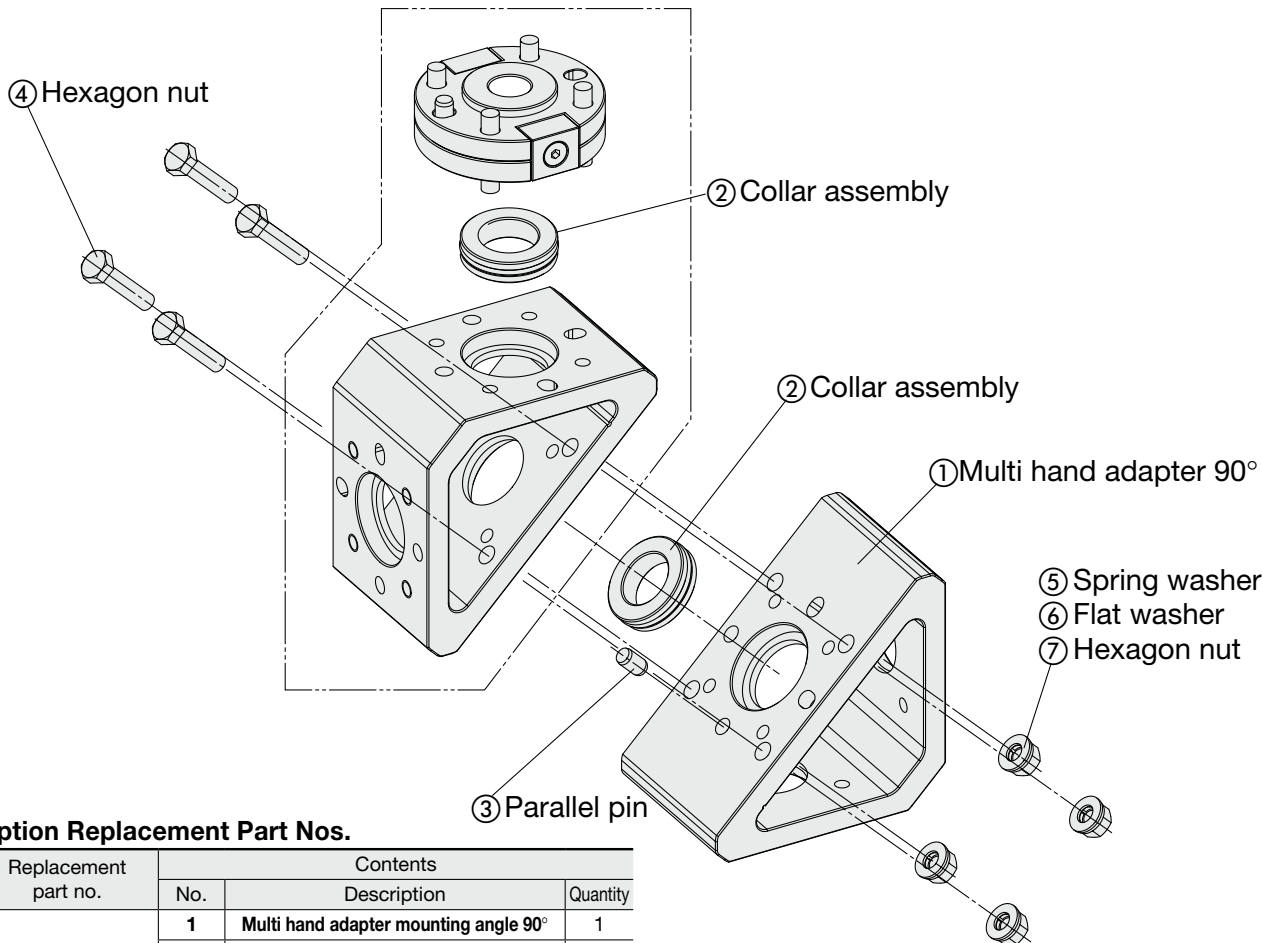

### Option Replacement Part Nos.

Replacement part no.	Contents		
	No.	Description	Quantity
RMMA-A11-01	1	Multi hand adapter mounting angle 90°	1
	2	Collar assembly	1
	3	Parallel pin	1
	4	Hexagon nut	4
	5	Spring washer	4
	6	Flat washer	4
	7	Hexagon nut	4

Weight: 396 g

## Gripper Mounting Examples

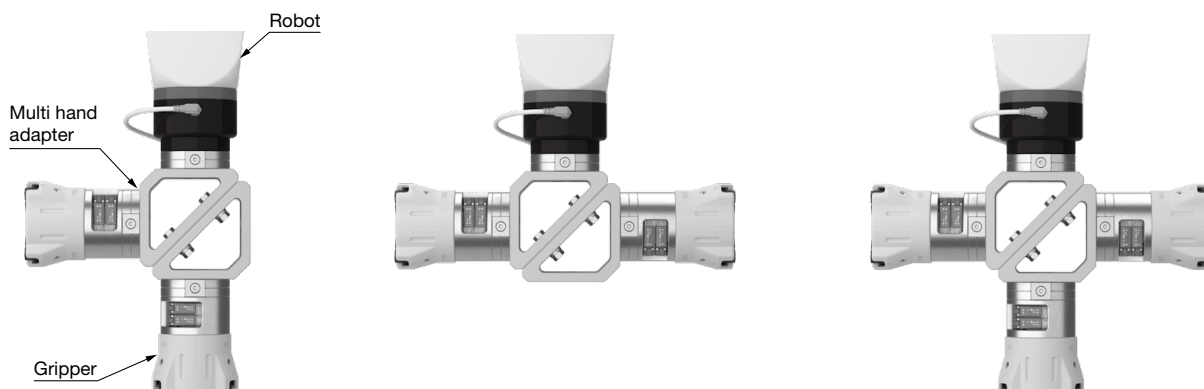

# RMMA Series

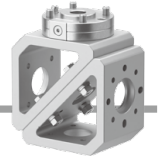

## Dimensions: Mounting Angle 180° Parts Set

RMMA1-20T090-E-01

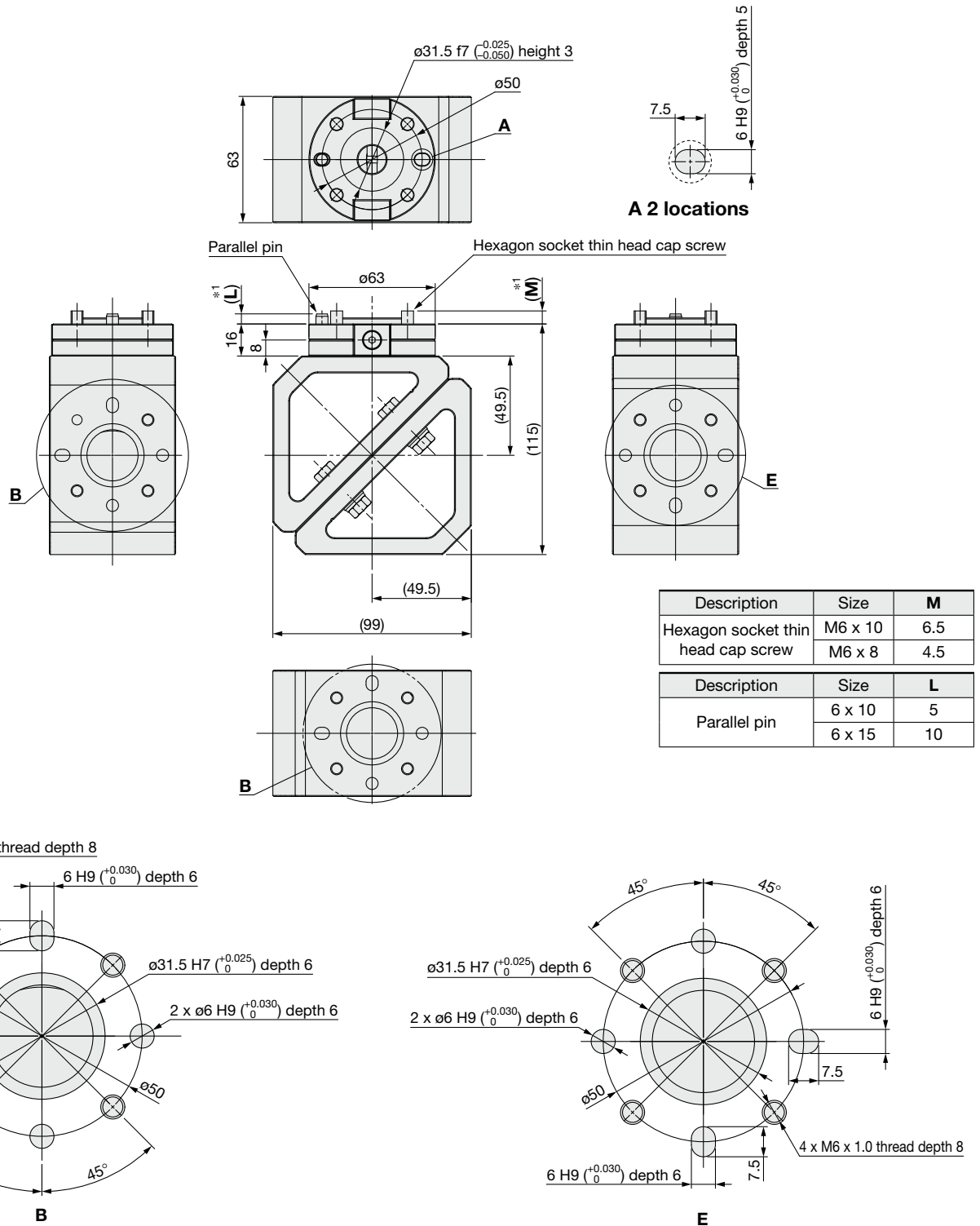

\*1 Two types of main plate mounting bolts and two types of parallel pins, with different lengths, are supplied with the product. Select parts that suit the robot in use.



# RMMA Series Connector Cable

A cable to connect grippers and an additional I/O terminal when performing electrical wiring with 2 or more grippers

Part name: Connector cable  
Order no.: RMH-A00-18A



## Specifications

Standards	IEC61076-2-104 compliant
Connector type	M8 socket
Number of poles	8
Keying	A
Rated voltage	30 VDC
Rated current	1A
Conductor	AWG26
Terminal processing	Half-stripped
Operating temperature range	-10 to +60°C

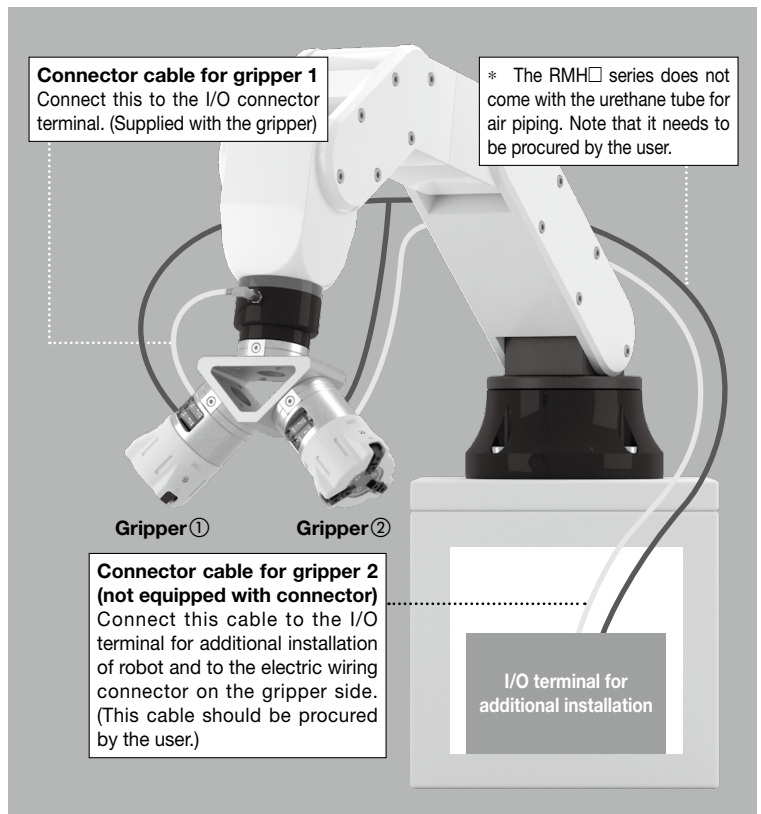

## Dimensions

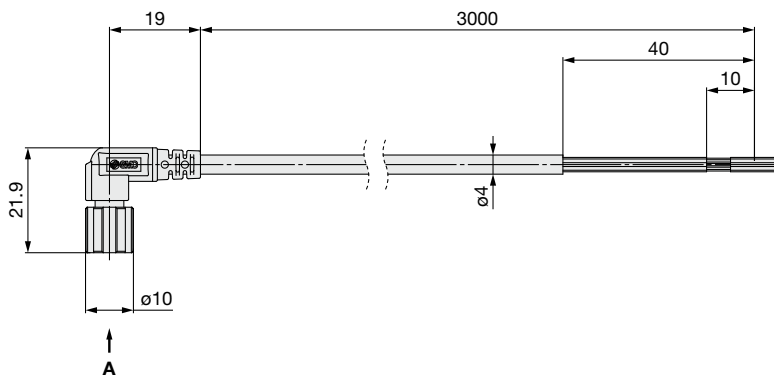

A (Pin no.) (5 : 1)

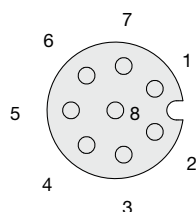

## Wiring

Connector	Pin no.	Wiring color
M8-8 pin Angled connector (Socket)	1	White
	2	Brown
	3	Green
	4	Yellow
	5	Gray
	6	Black
	7	Blue
	8	Red

## ⚠ Caution

The pin arrangement varies depending on the robot manufacturer.  
Refer to the operation manuals of the grippers and robots to be used for details.

**RMMA Series**

**Related Product**



# Air Grippers for Collaborative Robots

**RMH□ Series**

## Unitization of the peripheral devices required for gripper driving

Operation is possible simply by connecting 1 air supply tube and 1 electrical cable.

**Built-in**

**Solenoid valve**

**Exhaust throttle valve with silencer**

**Auto switch**

**Fitting**

\* The attachment should be ordered separately by the customer.

## 3 types of grippers available for use with a variety of workpieces

**Standard Type**



**RMHZ2 Series**

**3-Finger Type**



**RMHS3 Series**

**Long Stroke Type**

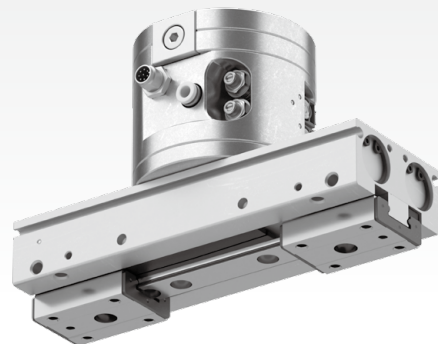

**RMHF2 Series**

## Can be used with the collaborative robots of 12 companies

UNIVERSAL ROBOTS, OMRON/TECHMAN ROBOT, FANUC, YASKAWA Electric, Mitsubishi Electric, HAN'S ROBOT, KUKA, DOOSAN ROBOTICS, SIASUN, JAKA, AUBO, ABB

## Safety Instructions

These safety instructions are intended to prevent hazardous situations and/or equipment damage. These instructions indicate the level of potential hazard with the labels of “**Caution**,” “**Warning**” or “**Danger**.” They are all important notes for safety and must be followed in addition to International Standards (ISO/IEC)\*1), and other safety regulations.

 **Danger :** **Danger** indicates a hazard with a high level of risk which, if not avoided, will result in death or serious injury.

 **Warning:** **Warning** indicates a hazard with a medium level of risk which, if not avoided, could result in death or serious injury.

 **Caution:** **Caution** indicates a hazard with a low level of risk which, if not avoided, could result in minor or moderate injury.

\*1) ISO 4414: Pneumatic fluid power - General rules and safety requirements for systems and their components  
ISO 4413: Hydraulic fluid power - General rules and safety requirements for systems and their components  
IEC 60204-1: Safety of machinery - Electrical equipment of machines - Part 1: General requirements  
ISO 10218-1: Robots and robotic devices - Safety requirements for industrial robots - Part 1: Robots etc.

### Warning

#### 1. The compatibility of the product is the responsibility of the person who designs the equipment or decides its specifications.

Since the product specified here is used under various operating conditions, its compatibility with specific equipment must be decided by the person who designs the equipment or decides its specifications based on necessary analysis and test results. The expected performance and safety assurance of the equipment will be the responsibility of the person who has determined its compatibility with the product. This person should also continuously review all specifications of the product referring to its latest catalog information, with a view to giving due consideration to any possibility of equipment failure when configuring the equipment.

#### 2. Only personnel with appropriate training should operate machinery and equipment.

The product specified here may become unsafe if handled incorrectly. The assembly, operation and maintenance of machines or equipment including our products must be performed by an operator who is appropriately trained and experienced.

#### 3. Do not service or attempt to remove product and machinery/equipment until safety is confirmed.

1. The inspection and maintenance of machinery/equipment should only be performed after measures to prevent falling or runaway of the driven objects have been confirmed.
2. When the product is to be removed, confirm that the safety measures as mentioned above are implemented and the power from any appropriate source is cut, and read and understand the specific product precautions of all relevant products carefully.
3. Before machinery/equipment is restarted, take measures to prevent unexpected operation and malfunction.

#### 4. Our products cannot be used beyond their specifications. Our products are not developed, designed, and manufactured to be used under the following conditions or environments. Use under such conditions or environments is not covered.

1. Conditions and environments outside of the given specifications, or use outdoors or in a place exposed to direct sunlight.
2. Use for nuclear power, railways, aviation, space equipment, ships, vehicles, military application, equipment affecting human life, body, and property, fuel equipment, entertainment equipment, emergency shut-off circuits, press clutches, brake circuits, safety equipment, etc., and use for applications that do not conform to standard specifications such as catalogs and operation manuals.
3. Use for interlock circuits, except for use with double interlock such as installing a mechanical protection function in case of failure. Please periodically inspect the product to confirm that the product is operating properly.

### Caution

**We develop, design, and manufacture our products to be used for automatic control equipment, and provide them for peaceful use in manufacturing industries.**

**Use in non-manufacturing industries is not covered.**

Products we manufacture and sell cannot be used for the purpose of transactions or certification specified in the Measurement Act.

The new Measurement Act prohibits use of any unit other than SI units in Japan.

## Limited warranty and Disclaimer/ Compliance Requirements

The product used is subject to the following “Limited warranty and Disclaimer” and “Compliance Requirements”.

Read and accept them before using the product.

### Limited warranty and Disclaimer

1. The warranty period of the product is 1 year in service or 1.5 years after the product is delivered, whichever is first.\*2)  
Also, the product may have specified durability, running distance or replacement parts. Please consult your nearest sales branch.
2. For any failure or damage reported within the warranty period which is clearly our responsibility, a replacement product or necessary parts will be provided. This limited warranty applies only to our product independently, and not to any other damage incurred due to the failure of the product.
3. Prior to using SMC products, please read and understand the warranty terms and disclaimers noted in the specified catalog for the particular products.

\*2) **Vacuum pads are excluded from this 1 year warranty.**

A vacuum pad is a consumable part, so it is warranted for a year after it is delivered.

Also, even within the warranty period, the wear of a product due to the use of the vacuum pad or failure due to the deterioration of rubber material are not covered by the limited warranty.

### Compliance Requirements

1. The use of SMC products with production equipment for the manufacture of weapons of mass destruction (WMD) or any other weapon is strictly prohibited.
2. The exports of SMC products or technology from one country to another are governed by the relevant security laws and regulations of the countries involved in the transaction. Prior to the shipment of a SMC product to another country, assure that all local rules governing that export are known and followed.

## Safety Instructions

Be sure to read the “Handling Precautions for SMC Products” (M-E03-3) and “Operation Manual” before use.

## SMC Corporation

Akihabara UDX 15F,  
4-14-1, Sotokanda, Chiyoda-ku, Tokyo 101-0021, JAPAN  
Phone: 03-5207-8249 Fax: 03-5298-5362  
<https://www.smcworld.com>  
© 2024 SMC Corporation All Rights Reserved

Specifications are subject to change without prior notice and any obligation on the part of the manufacturer.

D-G