

Auto Drain Valve

AD402-A Series

RoHS

Longer life & Higher resistance to foreign matter

Improved foreign matter resistance

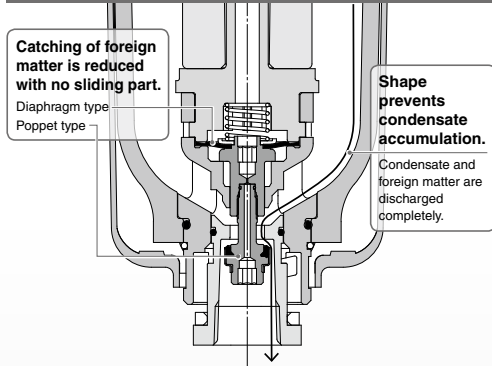

Piping direction **Vertical**



Double layer design

- Better visibility & environmental resistance
- The bowl is covered with a transparent bowl guard.

With manual discharge mechanism

N.O.: Black
N.C.: Gray

Increase in condensate discharge

Reduction of operation frequency due to increased condensate discharge

- Drain discharge: Max. **100 cm³/cycle**
(3 times compared with the current model)

New A lateral piping specification has been added.

Piping direction **Lateral**



Lightweight

- Resin bowl guard has reduced the weight by up to 22%

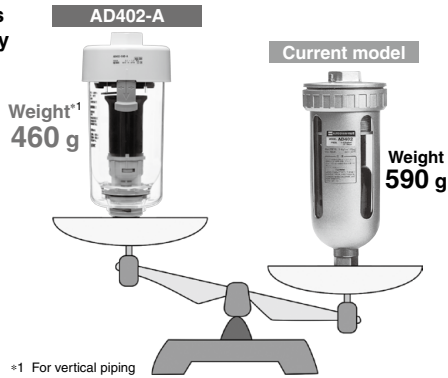

Reduced required maintenance space

- Only 30 mm of space is required underneath for maintenance, allowing more compact installation.

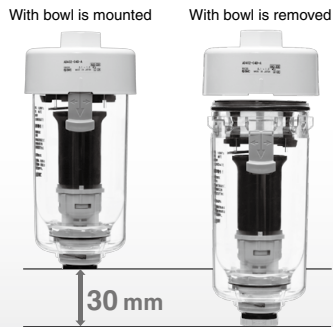
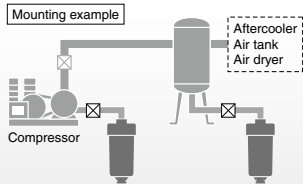

Easier maintenance

- One-touch mounting and removal of the bowl is possible without using a tool.

Release the lock by sliding the lock button down while holding the body. Then, rotate the bowl guard and pull down for removal.



Selectable piping direction

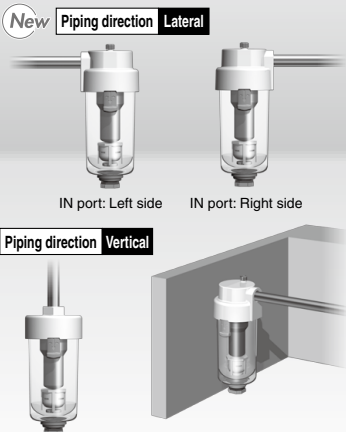

Transparent bowl guard

■ Better environmental resistance: Transparent bowl guard can protect the inner bowl!

Windows on the bowl guard have been removed and the inner bowl is instead covered with a polycarbonate transparent bowl guard. Now, even if the environment changes and the bowl is exposed to corrosive chemical or oil splash, the foreign matter will not stick directly to the pressurized bowl. This can reduce risk of bowl breakage.

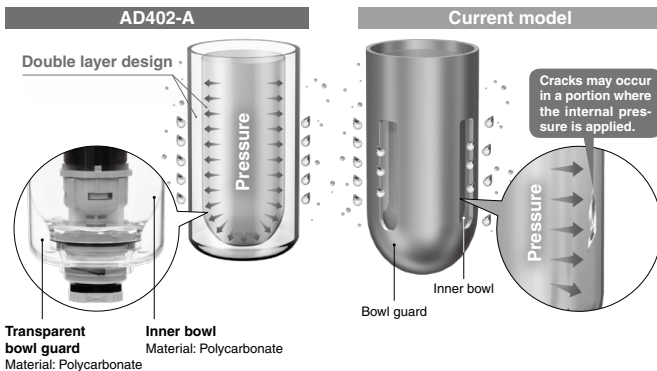

■ Better visibility: 360°

Use of transparent bowl guard makes it possible to check the condensate inside the bowl from the entire periphery.

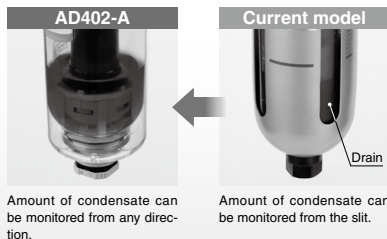

Options

■ Bowl material can be selected according to the operating environments.

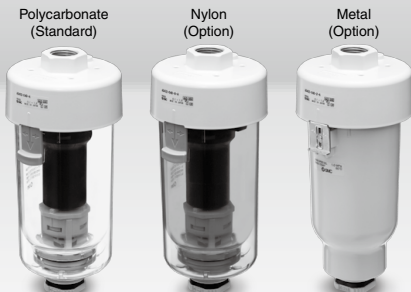

■ Bleed valve equipped type can be selected.



Auto Drain Valve

AD402-A Series

Piping direction **Vertical**



Symbol



Piping direction **Lateral**



Flow direction: IN port: Left side

Flow direction: IN port: Right side

Specifications

Standard Specifications

Model	AD402-A	AD402-TA
Piping direction	Vertical (From the top of the product)	Lateral (From the side of the product)
Auto drain type	Float type	
Auto drain valve type	N.C. (Normally closed: Drain port is closed when pressure is not applied) N.O. (Normally open: Drain port is open when pressure is not applied)	
Fluid	Compressed air	
Ambient and fluid temperatures	-5 to 60°C (No freezing)	
Proof pressure	1.5 MPa	
Max. operating pressure	1.0 MPa	
Operating pressure range^{*1}	N.C.	0.15 to 1.0 MPa
	N.O.	0.1 to 1.0 MPa
Port size	1/4, 3/8, 1/2	
Drain port size	3/8	
Bowl material	Polycarbonate	
Bowl guard material	Polycarbonate	
Weight	0.46 kg	0.52 kg
Appearance color	White	

*1 For the N.O. (Normally open) type, the discharged flow rate of the air compressor should be 400 L/min (ANR) or more.

How to Order

AD402 - **04** **D** - **A**

Semi-standard symbol: When plural options are required, indicate them in alphanumeric order.
Example) AD402-N04D-2VZ-A

Piping direction

Symbol	Type
Nil	Vertical piping
T	Lateral piping

Thread type

Symbol	Type
Nil	Rc
F	G
N	NPT

Port size

Symbol	Port size
02	1/4
03	3/8
04	1/2

Auto drain type

Symbol	Description
C^{*1}	N.C. (Normally closed) Drain port is closed when pressure is not applied.
D^{*2}	N.O. (Normally open) Drain port is open when pressure is not applied.

*1 When pressure is not applied, condensate which does not start the auto drain mechanism will be left in the bowl. Releasing the residual condensate before ending operations for the day is recommended.

*2 If the compressor is smaller than 3.7 kW, or discharge flow is less than 400 L/min (ANR), air leakage from the drain cock may occur during start of operations. N.C. type is recommended.

Proper use of float type auto drain ▶ See **P.493**

Semi-standard specifications

Semi-standard	Symbol	Description
	Bowl ^{*3}	Nil
2		Metal bowl
6		Nylon bowl
Flow direction ^{*4}	Nil	IN port: Left side
	R	IN port: Right side
Valve	Nil	None ^{*5}
	V	With bleed valve
Pressure unit	Nil	Name plate and caution plate for bowl in SI units
	Z^{*6}	Name plate and caution plate for bowl in imperial units

*3 Chemical resistance of the bowl ▶ See **P.494**

*4 Applicable only when the piping direction is lateral piping
Indicates the port direction when the name plate is viewed from the front

*5 For port size 1/4, the valve already mounted.

*6 Only NPT can be selected.

This product is for overseas use only according to the New Measurement Act. (The SI unit type is provided for use in Japan.)

Construction/Dimensions

AD402-A Piping direction **Vertical**

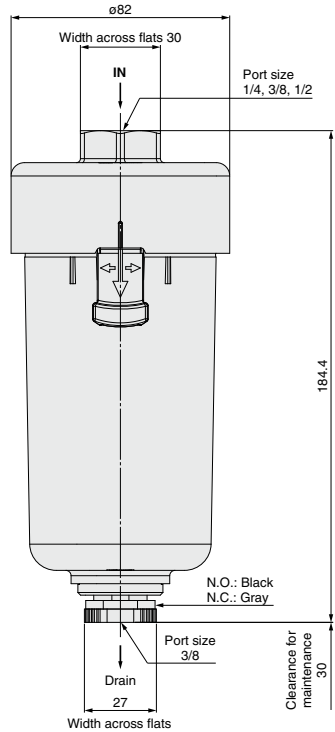
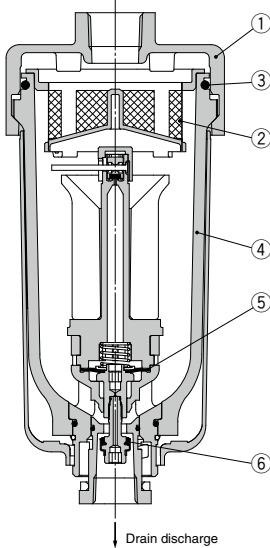

Component Parts

No.	Description	Material	Color
1	Body	Aluminum die-cast	White
5	Diaphragm	FKM	—
6	Main valve	FKM	—

Replacement Parts

No.	Description	Material	Part no.
2	Element	Nylon	AD402P-040S
3	Bowl O-ring	NBR	KA00463
4	Bowl assembly*1	See below.	See below.

Bowl Assembly Part Nos.

Bowl material	Bowl assembly part nos.	
	Normally open	Normally closed
Polycarbonate	AD52□-A	AD51□-A
Nylon	AD52□-6-A	AD51□-6-A
Metal	AD52□-2-A	AD51□-2-A

*1 Enter the piping thread type to □ of the bowl assembly part number.

Nil: Rc thread, N: NPT thread, F: G thread

Please consult with SMC separately for psi and °F unit display specifications. Including the bowl O-ring.

Bleed valve

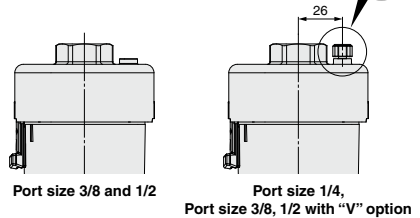
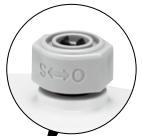

AD402-A Series

Construction/Dimensions

AD402T-A Piping direction **Lateral**

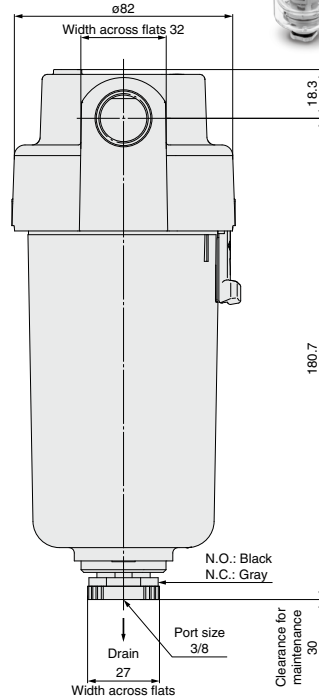
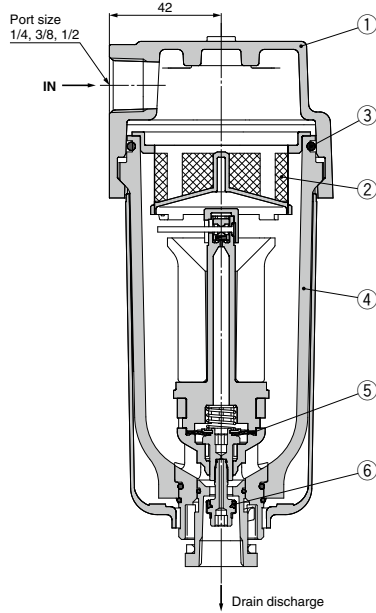

Component Parts

No.	Description	Material	Color
1	Body	Aluminum die-cast	White
5	Diaphragm	FKM	—
6	Main valve	FKM	—

Replacement Parts

No.	Description	Material	Part no.
2	Element	Nylon	AD402P-040S
3	Bowl O-ring	NBR	KA00463
4	Bowl assembly*1	See below.	See below.

Bowl Assembly Part Nos.

Bowl material	Bowl assembly part nos.	
	Normally open	Normally closed
Polycarbonate	AD52□-A	AD51□-A
Nylon	AD52□-6-A	AD51□-6-A
Metal	AD52□-2-A	AD51□-2-A

*1 Enter the piping thread type to □ of the bowl assembly part number.
Nil: Rc thread, N: NPT thread, F: G thread
Please consult with SMC separately for psi and °F unit display specifications.
Including the bowl O-ring.

Bleed valve

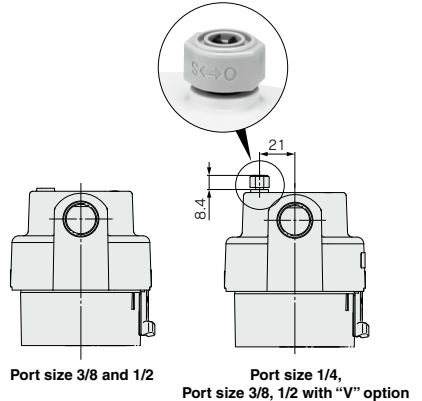

AD402-A Series

Working Principle: Float Type Auto Drain

N.O. (Normally open)

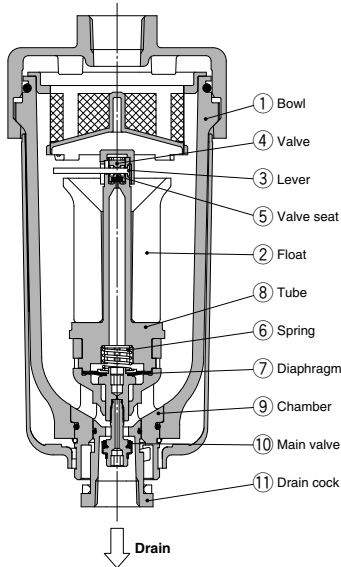

● When pressure inside the bowl is released:

When pressure is released from the bowl ①, the diaphragm ⑦ is lowered by the spring ⑥. The seal at the main valve ⑩ is interrupted, and the outside air flows inside the bowl ① through the chamber ⑨ and the drain cock ⑪. Therefore, if there is an accumulation of condensate in the bowl ①, it will drain out through the drain cock.

● When pressure is applied inside the bowl:

When pressure inside the bowl is 0.1 MPa or higher, the force of the diaphragm ⑦ surpasses the force of the spring ⑥, and the diaphragm goes up. This pushes the main valve ⑩ up so that it creates a seal, and the inside of the bowl ① is shut off from the outside air. If there is no accumulation of condensate in the bowl ① at this time, the float ② will be pulled down by its own weight, causing the valve ④, which is connected to the lever ③, to seal the valve seat ⑤.

● When there is an accumulation of condensate in the bowl:

The float ② rises due to its own buoyancy and the seal at the valve seat ⑤ is interrupted. This allows the pressure inside the bowl ① to enter the tube ⑧. The result is that the combined pressure inside the tube ⑧ and the force of the spring ⑥ lowers the diaphragm ⑦. This causes the seal at the main valve ⑩ to be interrupted, and the accumulated condensate in the bowl ① drains out through the drain cock ⑪.

Turning the drain cock ⑪ manually counterclockwise rises the drain cock ⑪, which pushes open the seal created by the main valve ⑩, thus allowing the condensate to drain out.

N.C. (Normally closed)

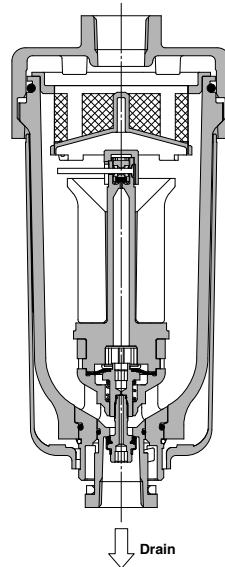

● When pressure inside the bowl is released:

Even when pressure inside the bowl ① is released, the spring ⑥ keeps the diaphragm ⑦ in its upward position. This keeps the seal created by the main valve ⑩ in place; thus, the inside of the bowl ① is shut off from the outside air. Therefore, even if there is an accumulation of condensate in the bowl ①, it will not drain out.

● When pressure is applied inside the bowl:

Even when pressure is applied inside the bowl ①, the combined force of the spring ⑥ and the pressure inside the bowl ① keeps the diaphragm ⑦ in its upward position. This maintains the seal created by the main valve ⑩ in place; thus, the inside of the bowl ① is shut off from the outside air. If there is no accumulation of condensate in the bowl ① at this time, the float ② will be pulled down by its own weight, causing the valve ④, which is connected to the lever ③, to seal the valve seat ⑤.

● When there is an accumulation of condensate in the bowl:

The float ② rises due to its own buoyancy and the seal at the valve seat ⑤ is interrupted. This allows the pressure inside the bowl ① to enter the tube ⑧. The result is that the pressure inside the tube ⑧ surpasses the force of the spring ⑥ and pushes the diaphragm ⑦ downward. This causes the seal at the main valve ⑩ to be interrupted and the accumulated condensate in the bowl ① drains out through the drain cock ⑪.

Turning the drain cock ⑪ manually counterclockwise rises the drain cock ⑪, which pushes open the seal created by the main valve ⑩, thus allowing the condensate to drain out.

Operating State and Proper Use of Float Type Auto Drain

Auto drain	When pressure is not applied (After exhausting residual pressure)	When pressure is applied		Minimum operating pressure
		Before drain accumulates	When drain accumulates	
N.O. (Normally open)	Drain discharged (Open) 	Drain not discharged (Close) 	Drain discharged (Open) 	0.1 MPa or more
N.C. (Normally closed)	Drain not discharged (Close) 			0.15 MPa or more

* For both N.O. and N.C., the drain can be discharged manually by turning the drain cock to the "O" position.

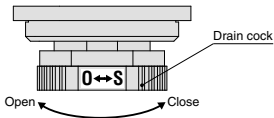

Proper use			Recommended auto drain
Compressor	When pressure is not applied (After exhausting residual pressure)	Cold climates	
<p>3.7 kW or more</p>	<p>Drain not accumulated</p> <p>Do not want to accumulate drain generated at the inlet side when pressure is not applied.</p>	<p>Want to prevent troubles caused by freezing.</p>	N.O.*1 (Normally open)
<p>Less than 3.7 kW</p>	<p>Drain accumulated</p>	—	N.C. (Normally closed)

*1 For N.O. type, the drain discharge passage is open when pressure is not applied. For this reason, the drain exhaust port is not closed completely in a compressor with a small supply amount (less than 3.7 kW) and the air will ceaselessly blow out.



AD402-A Series Specific Product Precautions 1

Be sure to read this before handling the products. Refer to page 9 for safety instructions and pages 10 to 12 for air preparation equipment precautions.

Design

Warning

1. The standard bowl for the auto drain valve is made of polycarbonate. Do not use in an environment where they are exposed to or come in contact with synthetic oil, organic solvents, chemicals, cutting oil, alkali, and thread lock solutions.

Effects of atmosphere of organic solvents and chemicals, and where these elements are likely to adhere to the equipment.

Chemical data for substances causing degradation (Reference)

Type	Chemical name	Application examples	Material	
			Polycarbonate	Nylon
Acid	Hydrochloric acid Sulfuric acid, Phosphoric acid Chromic acid	Acid washing liquid for metals	△	×
Alkaline	Sodium hydroxide (Caustic soda) Potash Calcium hydroxide (Slack lime) Ammonia water Carbonate of soda	Degreasing of metals Industrial salts Water-soluble cutting oil	×	○
Inorganic salts	Sodium sulfide Potassium nitrate Sulfate of soda	—	×	△
Chlorine solvents	Carbon tetrachloride Chloroform Ethylene chloride Methylene chloride	Cleansing liquid for metals Printing ink Dilution	×	△
Aromatic series	Benzene Toluene Paint thinner	Coatings Dry cleaning	×	△
Ketone	Acetone Methyl ethyl ketone Cyclohexane	Photographic film Dry cleaning Textile industries	×	×
Alcohol	Ethyl alcohol IPA Methyl alcohol	Anti-freeze Adhesives	△	×
Oil	Gasoline Kerosene	—	×	○
Ester	Dimethyl phthalate Diethyl phthalate Acetic acid	Synthetic oil Anti-rust additives	×	○
Ether	Methyl ether Ethyl ether	Brake oil additives	×	○
Amino	Methyl amino	Cutting oil Brake oil additives Rubber accelerant	×	×
Others	Thread-lock fluid Seawater Leak tester	—	×	△

○: Essentially safe △: Some effects may occur. ×: Effects will occur.

When the above factors are present, or there is some doubt, use a metal bowl for safety.

Warning

2. Keep the compressed air and the ambient temperature of the location where this product is installed within the range of -5 to 60°C. Exceeding this range could lead to a failure or malfunction.

3. Avoid using this product in an area where corrosive gases, flammable gases or organic solvents are contained in the compressed air or in the surrounding air.

Selection

Caution

1. Operate under the following conditions to avoid malfunction.

<N.O. type>

- Operating pressure: 0.1 MPa or more
 - Operate the compressor at 3.7 kW (400 L/min (ANR)) or more.
- Air may ceaselessly blow out of the drain discharge area when a compressor with a small air discharge volume is used since the valve does not close unless the air pressure is 0.1 MPa or higher.

<N.C. type>

- Operating pressure: 0.15 MPa or more

2. Operation failure will occur if a large amount of condensate rushes into the valve. Do not use the auto drain valve in such environment.

Piping

Warning

1. Hold the female thread side and tighten to the recommended torque when screwing in the piping material.

Insufficient tightening torque may cause loosening or defective sealing. Excessive tightening torque may damage the thread, etc.

If it is tightened without holding the female thread side, excessive force will be directly applied to the internal parts, resulting in a product failure.

Recommended Torque

Unit: N·m

Connection thread	1/4	3/8	1/2
Torque	12 to 14	22 to 24	28 to 30

2. Preparation before piping

Before piping is connected, it should be thoroughly blown out with air (flushing) or washed to remove chips, cutting oil, and other debris from inside the pipe.

3. Winding of sealant tape

When screwing piping or fittings into ports, ensure that chips from the pipe threads or sealing material do not enter the piping. Also, if sealant tape is used, leave 1.5 to 2 thread ridges exposed at the end of the threads.

4. For drain piping, use piping whose I.D. is ϕ 10 mm or larger, and whose length is 5 m or less. Avoid riser piping.



AD402-A Series Specific Product Precautions 2

Be sure to read this before handling the products. Refer to page 9 for safety instructions and pages 10 to 12 for air preparation equipment precautions.

Mounting

⚠ Caution

1. About the mounting orientation of the products

Be sure to install the product with "out port" down in a vertical position. If it is installed diagonally, laterally, or upside down, the drain may splash to the outlet side.

2. Install with at least 30 mm of free space below the product to allow for maintenance.

3. To place this product near the air compressor, install in such a way that the vibrations will not be transmitted.

4. When installing the bowl, install it so that the lock button lines up to the groove of the front (or the back) of the body.

Failure to do so may cause the bowl to fall off or break.



Air Supply

⚠ Caution

1. The product is not applicable to gases other than compressed air.

The product is not applicable to gases other than compressed air (example: oxygen, hydrogen, flammable gas, mixed gas).

2. Do not use compressed air that contains chemicals, organic solvents, salt, or corrosive gases.

Do not use compressed gas containing chemicals, organic solvents, salt or corrosive gas. This can cause rust, damage to rubber and resin parts, or malfunction.

3. Operate within the specified operating pressure range.

Damage, failure, or malfunction may occur if the product is operated above the maximum operating pressure.

Operating Environment

⚠ Warning

1. Do not use in explosive atmospheres.

2. Do not use in locations subject to vibration or impact.

3. A protective cover should be used to shield the product from direct sunlight.

4. Remove any sources of excessive heat.

Maintenance

⚠ Warning

1. Perform maintenance inspection according to the procedures indicated in the operation manual. If handled improperly, the malfunction or damage of machinery and equipment may occur.

2. Perform periodical inspections to detect any cracks, scratches, or other deterioration of the resin bowl. Replace with a new bowl or metal bowl when any kind of deterioration is found. Otherwise, damage may occur. Investigate and/or review the operating conditions if necessary.

3. And if removing the dirt by washing the resin bowl, never use washing materials other than a neutral detergent. Failure to do so may cause damage to the bowl.

⚠ Caution

1. Manual operation

A manual knob attached to the auto drain end is tightened to the "S" side in normal operation. The drain can be discharged by loosening it to the "O" side. (Be careful, however, if pressure remains inside the bowl when the drain is discharged, the drain will blow out from the drain port.)

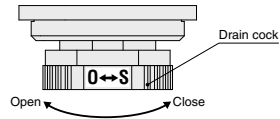

2. When discharging condensate manually, do not apply excessive torque to the drain cock by using a tool. Failure to do so may cause damage to the product.

3. When removing the bowl, if the bowl does not rotate smoothly, slide the bowl upward and then rotate it.

