

# 3-Position Rotary Table

## MSZ Series

Size: 10, 20, 30, 50

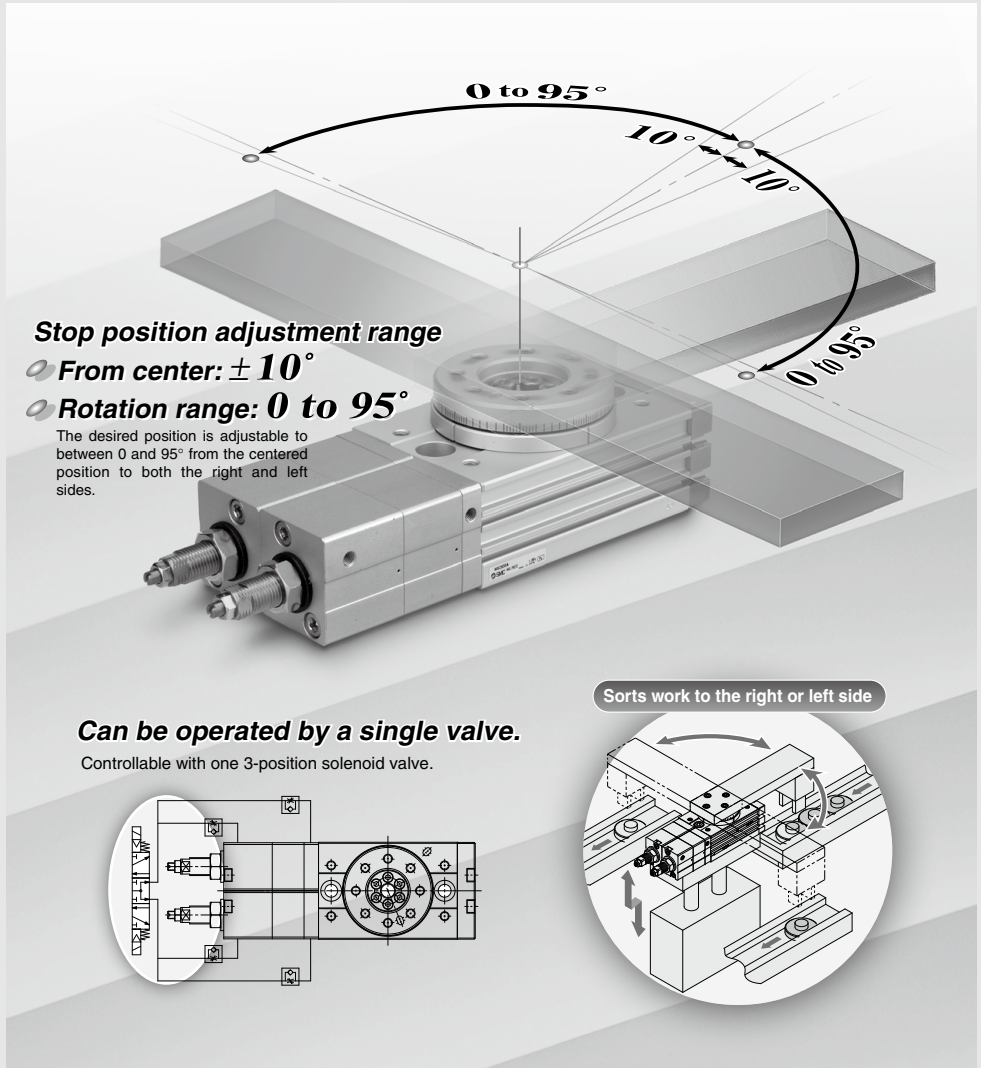

## Example of Stop Position Settings

Angle adjustable as shown below. (CCW: Counterclockwise, C: Center, CW: Clockwise)

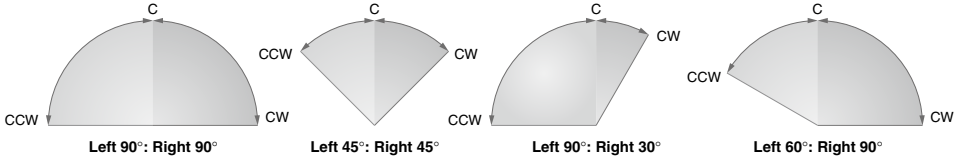

## Working Principle

This model uses a 3-position 5-port solenoid valve (pressure center). When air is supplied to all ports after the solenoid valve is pressure-center positioned, the pistons for rotary operation do not have any thrust, as the pressure in both sides is equal, and the pistons for rotary operation move to the center position due to the thrust of the pistons for center stop. When all of the pistons (center stop and rotary operation) are in contact with each other, the piston system stops.

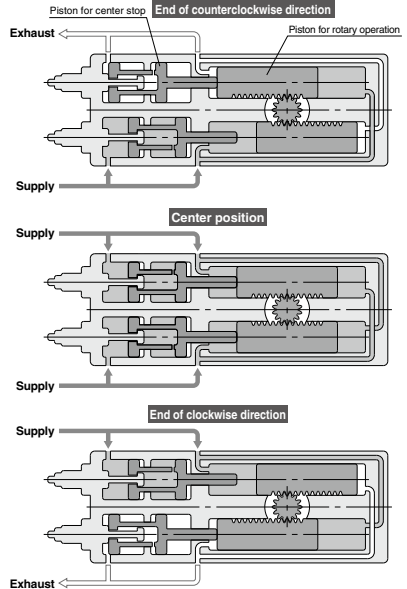
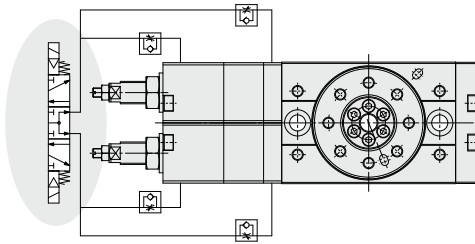

- A load can be mounted directly on the table.
- A High-precision model is also available in addition to the basic model.

Basic model: **MSZB**

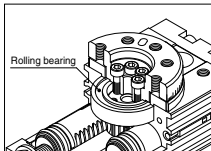

High-precision model: **MSZA**

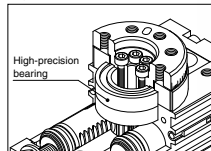

Model	Size	Torque (N·m) (at 0.5 MPa)	Port size
Basic <b>MSZB</b>	10	1	M5 x 0.8
	20	2	
High-precision <b>MSZA</b>	30	3	
	50	5	

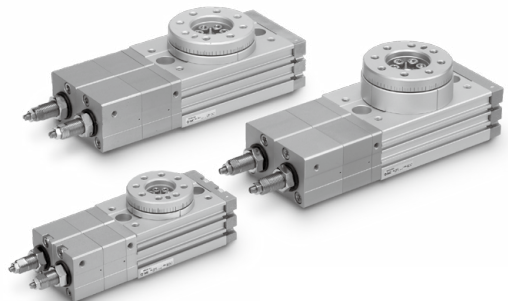

## Effective Torque

Unit: N·m

Size	Operating direction	Operating pressure (MPa)								
		0.2	0.3	0.4	0.5	0.6	0.7	0.8	0.9	1
10	End→Center	0.38	0.60	0.83	1.06	1.28	1.51	1.73	1.96	2.18
	Center→End	0.29	0.50	0.70	0.90	1.10	1.30	1.51	1.71	1.91
20	End→Center	0.72	1.14	1.55	1.97	2.39	2.81	3.22	3.64	4.06
	Center→End	0.62	1.01	1.40	1.78	2.17	2.56	2.95	3.34	3.73
30	End→Center	1.09	1.72	2.36	3.00	3.63	4.27	4.90	5.54	6.18
	Center→End	0.91	1.49	2.07	2.65	3.23	3.81	4.39	4.97	5.55
50	End→Center	1.83	2.83	3.84	4.84	5.84	6.85	7.85	8.85	9.85
	Center→End				4.75	5.74	6.74	7.73	8.72	9.72

Note) Effective torque values are representative values and not to be considered as guaranteed values.  
Torque changes depending on the rotating direction. Please refer to the figure below for the rotating directions.

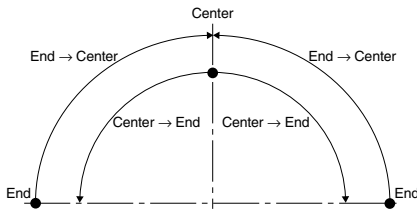

## Allowable Load

Do not allow the load and moment applied to the table to exceed the allowable values shown in the table below.  
(Operation beyond the allowable values can cause adverse effects on service life, such as play in the table and loss of accuracy.)

Size	Allowable radial load (N)		Allowable thrust load (N)				Allowable moment (N·m)	
	Basic type	High precision type	(a)		(b)		Basic type	High precision type
			Basic type	High precision type	Basic type	High precision type		
10	78	86	78	107	74	74	2.4	2.9
20	147	166	137	197	137	137	4.0	4.8
30	196	233	363	398	197	197	5.3	6.4
50	314	378	451	517	296	296	9.7	12.0

# MSZ Series

## Kinetic Energy/Rotation Time

**Model selection** Select models by applying the inertial moment and rotation time which have been found to the charts below.

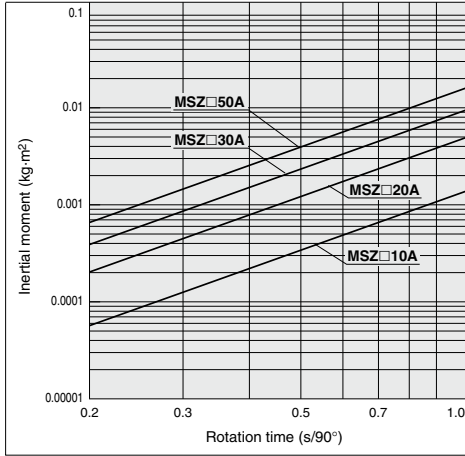

## Rotation Accuracy: Displacement Values at 180° (Reference values)

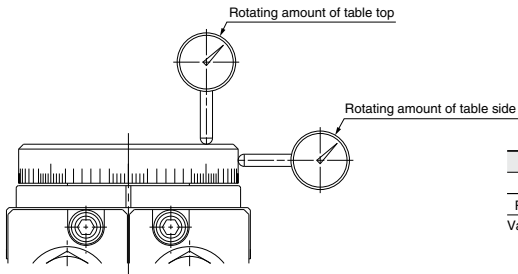

Measuring plate	MSZA	MSZB	mm
Rotating amount of table top	0.03	0.1	
Rotating amount of table side	0.03	0.1	

Values in the table are actual values and not guaranteed values.

## Table Displacement (Reference values)

- The following graphs show the displacement at point A, which is 100 mm apart from the center of rotation, where the load is applied.

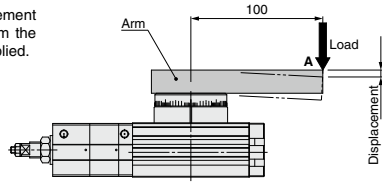

**MSZ□10A**

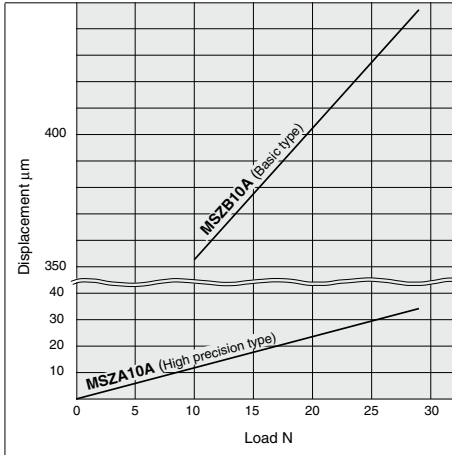

**MSZ□20A**

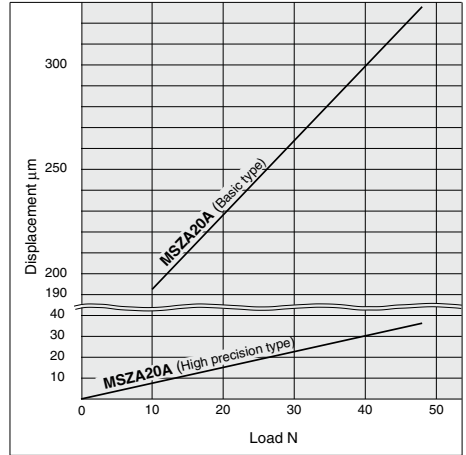

**MSZ□30A**

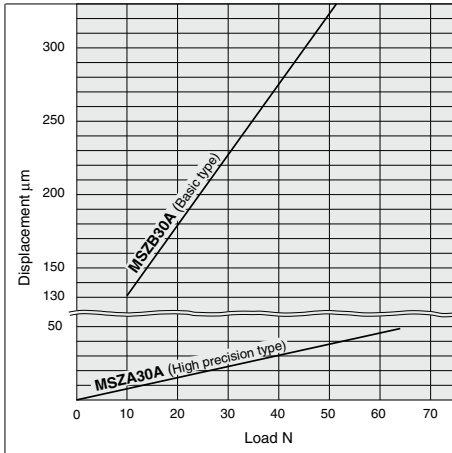

**MSZ□50A**

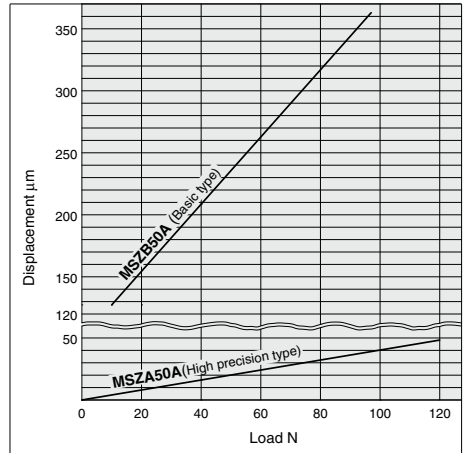

# Rotary Table Air Consumption

Air consumption is the volume of air which is expended by the rotary table's reciprocal operation inside the actuator and in the piping between the actuator and the switching valve, etc. This is necessary for selection of a compressor and for calculation of its running cost.

$$Q_{CR} = V \times \left( \frac{P+0.1}{0.1} \right) \times 10^{-3} \quad \dots(1)$$

$$Q_{CF} = a \times L \times \frac{P}{0.1} \times 10^{-6} \quad \dots(2)$$

$Q_{CR}$ = Amount of air consumption of rotary table	[L (ANR)]
$Q_{CF}$ = Amount of air consumption of tube or piping	[L (ANR)]
$V$ = Inner volume of the rotary table	[cm <sup>3</sup> ]
$P$ = Operating pressure	[MPa]
$L$ = Length of piping	[mm]
$a$ = Inner sectional area of piping	[mm <sup>2</sup> ]

Internal volume changes depending on the rotating direction (refer to the figure shown in the lower right). Because of this, to obtain the total air consumption, first calculate the air consumption of each stroke respectively by using formula (1), then add up each result.

Air in the tubing is consumed only when the table rotates from end to center. The air consumption in the tubing can be obtained by using formula (2).

The internal volume for each rotating direction and air consumption at each operating pressure calculated using formula (1) are shown in the table below.

To select a compressor, it is important to select one that has plenty of margin to accommodate the total air volume that is consumed by the pneumatic actuators that are located downstream. The total air consumption volume is affected by the leakage in the tube, the consumption in the drain valves and pilot valves, as well as by the reduction in air volume due to reduced temperature.

Formula

$$Q_{c2} = Q_c \times n \times \text{No. of actuators} \times \text{Margin rate}$$

$Q_{c2}$  = Amount of exhaust air from a compressor [L/min (ANR)]  
 $n$  = Actuator oscillations per minute

## Internal Cross Section of Tubing and Steel Piping

Nominal	O.D. (mm)	I.D. (mm)	Internal cross section a (mm <sup>2</sup> )
T□0425	4	2.5	4.9
T□0604	6	4	12.6
TU 0805	8	5	19.6
T□0806	8	6	28.3
1/8B	—	6.5	33.2
T□1075	10	7.5	44.2
TU 1208	12	8	50.3
T□1209	12	9	63.6
1/4B	—	9.2	66.5
TS 1612	16	12	113
3/8B	—	12.7	127
T□1613	16	13	133
1/2B	—	16.1	204
3/4B	—	21.6	366
1B	—	27.6	598

[Calculation example]

Size: 10 Operating pressure: 0.5 MPa Inner sectional area of piping: 12.6 mm<sup>2</sup>  
 Length of piping: 1000 mm Stroke: Center → Counterclockwise → Center → Clockwise → Center  
 Total air consumption, Q<sub>1</sub>, is obtained by adding up the air consumption of each stroke, which is shown in the table below.

$$Q_1 = 0.019 + 0.040 + 0.019 + 0.040 = 0.118 \text{ L (ANR)}$$

Air consumed in the tubing is calculated using formula (2), as shown below.

$$Q_2 = 12.6 \times 1000 \times \frac{0.5}{0.1} \times 10^{-6} = 0.063 \text{ L (ANR)}$$

An entire stroke includes two rotations from end to center where the air is consumed. Thus, the total air consumption Q of the rotary table and tubing is obtained as shown below.

$$Q = Q_1 + Q_2 \times 2 = 0.244 \text{ L (ANR)}$$

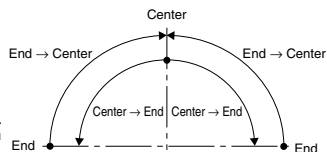

## Air Consumption

Air consumption of rotary table: Q<sub>CR</sub> L (ANR)

Size	Operating direction	Rotation	Inner volume (cm <sup>3</sup> )	Operating pressure (MPa)								
				0.2	0.3	0.4	0.5	0.6	0.7	0.8	0.9	1.0
10	End → Center	90°	6.69	0.020	0.027	0.033	0.040	0.047	0.054	0.060	0.067	0.074
	Center → End		3.11	0.009	0.012	0.016	0.019	0.022	0.025	0.028	0.031	0.034
20	End → Center		13.2	0.040	0.053	0.066	0.079	0.093	0.106	0.119	0.132	0.145
	Center → End		6.40	0.019	0.026	0.032	0.038	0.045	0.051	0.058	0.064	0.070
30	End → Center		20.0	0.060	0.080	0.100	0.120	0.140	0.160	0.180	0.200	0.220
	Center → End		9.52	0.029	0.038	0.048	0.057	0.067	0.076	0.086	0.095	0.105
50	End → Center		32.6	0.098	0.130	0.163	0.195	0.228	0.261	0.293	0.326	0.358
	Center → End		16.2	0.049	0.065	0.081	0.097	0.113	0.130	0.146	0.162	0.178

# 3-Position Rotary Table

# MSZ Series

Size: 10, 20, 30, 50

## How to Order

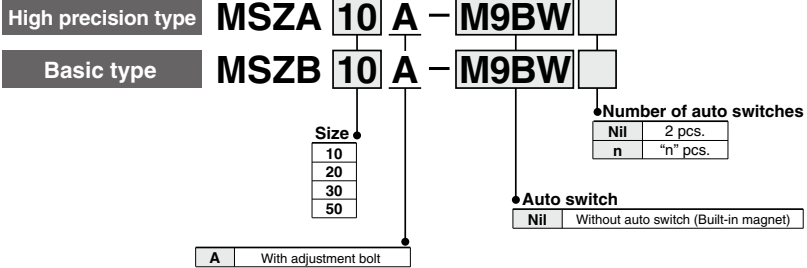

### Applicable Auto Switches

Refer to pages 929 to 983 for detailed auto switch specification.

Type	Special function	Electrical entry	Indicator light	Wiring (Output)	Load voltage		Auto switch model		Lead wire length (m)			Pre-wired connector	Applicable load				
					DC	AC	Perpendicular	In-line	0.5 (Nil)	1 (M)	3 (L)		5 (Z)				
Solid state auto switch	—	Grommet	Yes	3-wire (NPN)	24 V	5 V, 12 V	—	M9NV	M9N	●	●	●	○	○	Relay, PLC		
				3-wire (PNP)				M9PV	M9P	●	●	●	○	○			
	2-wire			M9BV	M9B	●	●	●	○	○	—						
	3-wire (NPN)			M9NWV	M9NW	●	●	●	○	○	IC circuit						
	3-wire (PNP)			M9PWV	M9PW	●	●	●	○	○	IC circuit						
	2-wire			M9BWV	M9BW	●	●	●	○	○	—						
Reed auto switch	—	Grommet	Yes	3-wire (NPN equiv.)	24 V	5 V	—	A96V	A96	●	—	●	—	—	IC circuit	Relay, PLC	
				2-wire				A93V*2	A93	●	●	●	—	—	—		
				No	—	100 V or less	A90V	A90	●	—	●	—	—	—	—		IC circuit
							M9NAV*1	M9NA*1	○	○	●	○	○	—			
							M9PAV*1	M9PA*1	○	○	●	○	○	—			
							M9BAV*1	M9BA*1	○	○	●	○	○	—			

\*1 Although it is possible to mount water resistant type auto switches, note that the rotary actuator itself is not of water resistant construction.

\*2 1 m type lead wire is only applicable to D-A93.

\* Lead wire length symbols: 0.5 m ..... Nil (Example) M9NW  
 1 m ..... M (Example) M9NWM  
 3 m ..... L (Example) M9NWL  
 5 m ..... Z (Example) M9NWX

\* Auto switches marked with a "○" are produced upon receipt of orders.

\* Refer to pages 970 and 971 for the details of solid state auto switch with pre-wired connector.

\* Auto switches are shipped together, (but not assembled).

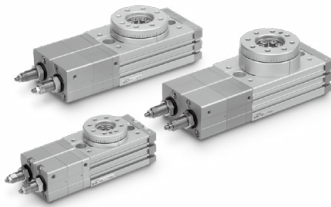

## Specifications

Size	10	20	30	50
Fluid	Air (non-lube)			
Maximum operating pressure	1 MPa			
Minimum operating pressure	0.2 MPa			
Ambient and fluid temperature	0 to 60°C (with no freezing)			
Cushion	None			
Rotation angle adjustment range	0 to 190°			
Center position adjustment range	±10°			
Port size	M5 x 0.8			

## Allowable Kinetic Energy and Rotation Time Adjustment Range

Size	Allowable kinetic energy (J)	Rotation time adjustment range for stable operation (s/90°)
10	0.007	0.2 to 1.0
20	0.025	
30	0.048	
50	0.081	

Note) If operated where the kinetic energy exceeds the allowable value, this may cause damage to the internal parts and result in product failure. Please pay special attention to the kinetic energy levels when designing, adjusting and during operation to avoid exceeding the allowable limit.

### Symbol

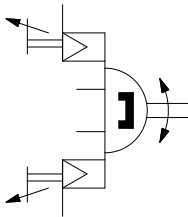

## Weight

Size	Unit: g			
	10	20	30	50
Basic type	700	1300	1670	2570
High precision type	730	1400	1790	2730

Note) Excluding the weight of auto switches.

## Piping and Speed Control

- 1) A single 3-position pressure center solenoid valve or two 3-port solenoid valves are used. (Refer to Figure 1 or Figure 2.)
- 2) A meter-out-type speed controller is used for ports **A** and **B** and a meter-in speed controller is used for ports **C** and **D**. (Figures 1 and 2 show the state at which pressure is applied to ports **B** and **D**.)

**Figure 1** 3-position pressure center solenoid valve: 1 pc.

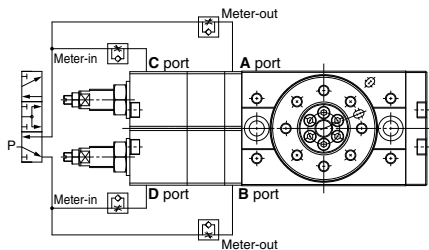

**Figure 2** 3-position solenoid valve: 2 pcs.

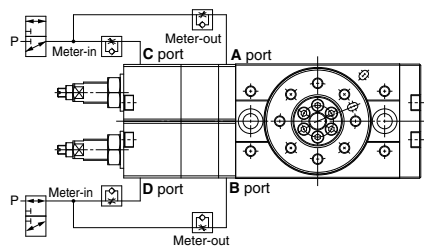

\* The table return position under the power-off state changes depending on the solenoid valve type. Please refer to page 375 for details.

- 3) Figure 3 shows the rotation range and Table 1 shows the active speed controller.

**Figure 3** Each operational contents

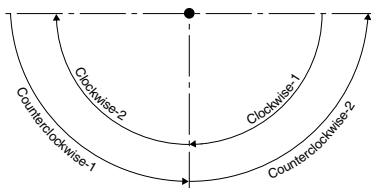

**Table 1** Pressure port and active speed controller

Operating	Pressure port		Speed controller
	A, C	B, D	
Clockwise-1	●	●	C port
Clockwise-2	●	—	B port
Counterclockwise-1	●	●	D port
Counterclockwise-2	—	●	A port



## Angle Adjustment

1) Stop positions are adjusted with the adjusting bolts shown in Figure 4.

- ① Adjusting bolts "a" and "b" are used for adjusting the rotation ends. Adjusting bolts "c" and "d" are used for adjusting the center position.
- ② Figure 5 shows angle ranges adjusted with each adjusting bolt.

2) Angle adjustment

Supply air when adjusting the angle

(a low pressure of approx. 0.2 MPa is recommended).

- ① First adjust both rotation end positions.
  - Apply pressure to ports A and C to adjust adjusting bolt "b".
  - Apply pressure to ports B and D to adjust adjusting bolt "a".
  - Lock the bolts with fixing nuts after adjustment.
- ② Next, apply pressure to ports A to D to adjust the center position.
  - Loosen the fixing nuts for adjusting bolts "c" and "d".
  - Tighten adjusting bolts "c" and "d" almost completely (allowing manual table rotation).
  - Follow the appropriate procedure (R or L) shown in Table 2.

**Figure 4** Adjustment bolt position

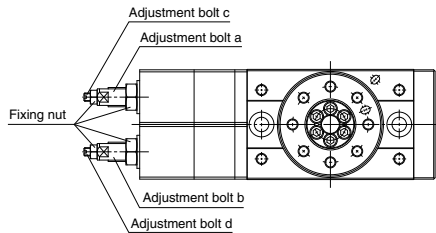

**Figure 5** Angle adjustment Range

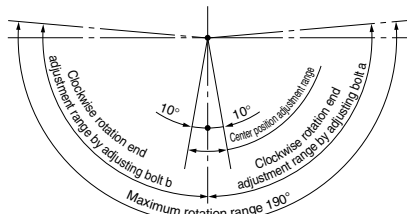

**Table 2** Center position adjustment

	R: Clockwise adjustment	L: Counterclockwise adjustment
1	Manually rotate the table counterclockwise until resistance is felt.	Manually rotate the table clockwise until resistance is felt.
2	Rotate the table clockwise when adjustment bolt "d" is loosened. Set it to the desired position.	Rotate the table counterclockwise when adjustment bolt "c" is loosened. Set it to the desired position.
3	Loosen adjustment bolt "c" until resistance is felt. (Make sure that there is no rotation backlash in the table.)	Loosen adjustment bolt "d" until resistance is felt. (Make sure that there is no rotation backlash in the table.)
4	Tighten both adjustment bolts "c" and "d" to approx. 45°. <i>Note 1)</i>	Tighten both adjustment bolts "c" and "d" to approx. 45°. <i>Note 1)</i>
5	Lock adjustment bolts "c" and "d" with fixing nuts. <i>Note 2)</i>	Lock adjustment bolts "c" and "d" with fixing nuts. <i>Note 2)</i>

Note 1) Since the position of the adjustment bolt shifts with changing the screw clearance, pre-tighten the fixing nuts.

Note 2) If the table has a rotation backlash after tightening the nut, readjust it.

### Adjusting angle per rotation of angle adjustment screw

size	Adjustment bolt a, b (End position adjustment)	Adjustment bolt c, d (Center position adjustment)
10	10.2°	5.1°
20	9.0°	3.6°
30	8.2°	3.3°
50	8.2°	4.1°

A piping, speed control, and angle adjustment manual is attached to the product.

# MSZ Series

## Construction

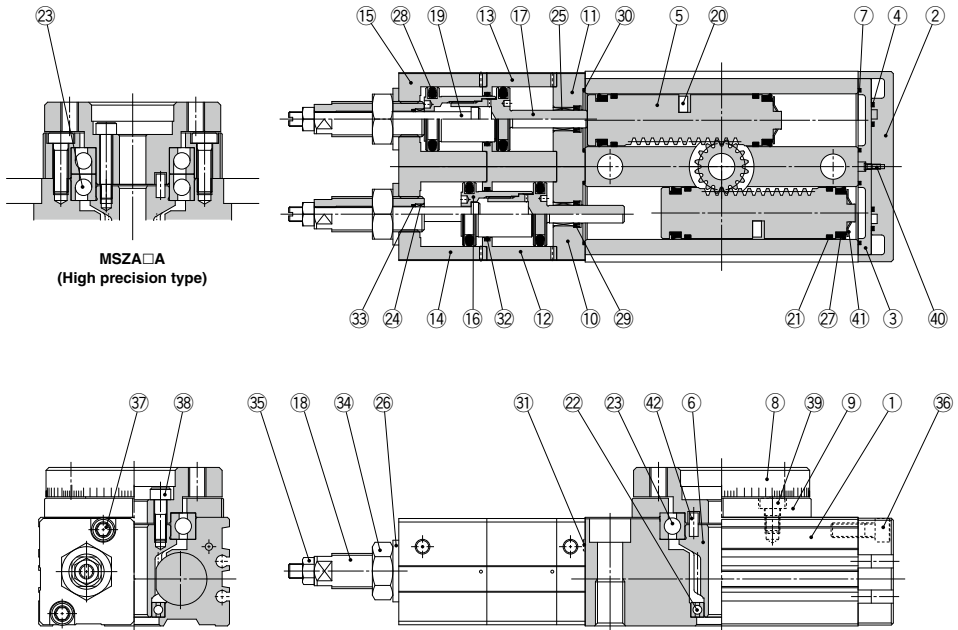

MSZ□A  
(High precision type)

### Component Parts

No.	Description	Material	Note
1	Body	Aluminum alloy	Anodized
2	Cover	Aluminum alloy	Nickel plated
3	Plate	Aluminum alloy	Chromated
4	Seal	NBR	
5	Piston	Stainless steel	
6	Pinion	Chrome molybdenum steel	
7	Gasket (for cover)	NBR	
8	Table	Aluminum alloy	Anodized
9	Bearing retainer	Aluminum alloy	Anodized
10	End cover A	Aluminum alloy	Anodized
11	End cover B	Aluminum alloy	Anodized
12	Cylinder tube A	Aluminum alloy	Anodized
13	Cylinder tube B	Aluminum alloy	Anodized
14	Tube cover A	Aluminum alloy	Anodized
15	Tube cover B	Aluminum alloy	Anodized
16	Sub piston R	Carbon steel	Nickel plated
17	Sub piston F	Carbon steel	Nickel plated
18	Adjustment bolt R	Carbon steel	Nickel plated
19	Adjustment bolt F	Carbon steel	Nickel plated
20	Magnet	—	
21	Wear ring	Resin	
22	Bearing	Bearing steel	

No.	Description	Material	Note
23	Basic type Bearing	Bearing steel	
	High precision type Angular bearing		
24	Bushing	—	
25	Bushing	—	
26	Seal washer	NBR	
27	Piston seal	NBR	
28	Piston seal	NBR	
29	Rod seal	NBR	
30	Gasket	NBR	
31	O-ring	NBR	
32	O-ring	NBR	
33	O-ring	NBR	
34	Compact hexagon nut	Steel wire	
35	Hexagon nut	Steel wire	
36	Hexagon socket head set bolt	Stainless steel	
37	Hexagon socket head set bolt	Stainless steel	
38	Hexagon socket head set bolt	Stainless steel	
39	Round head phillips screw	Size: 10	Stainless steel
	Hexagon thin socket head bolt	Size: 20, 30, 50	Chrome molybdenum steel
40	Round head phillips screw No.0	Steel wire	
41	Push nut	Stainless steel	
42	Parallel pin	Carbon steel	

\* The component parts cannot be shipped individually.

**Dimensions**

**Basic type/MSZB□A**

The position table shows the counterclockwise end when adjusted the rotation angle to 180°.

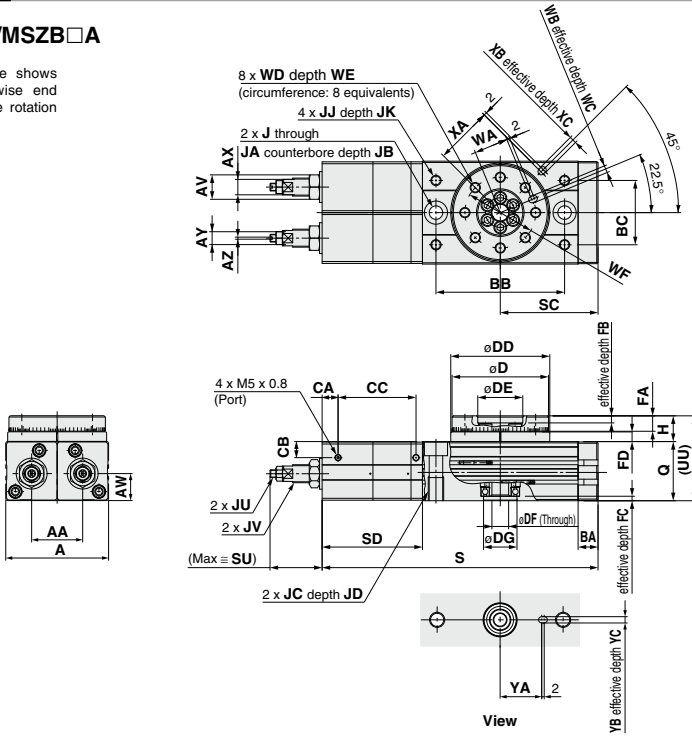

**High precision type/MSZA□A**

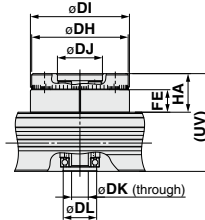

Size	DH	DI	DJ	DK	DL	FE	HA	UV
10	45h8	46h8	20H8	6	15H8	10	18.5	52.5
20	60h8	61h8	28H8	9	17H8	15.5	26	63
30	65h8	67h8	32H8	12	22H8	16.5	27	67
50	75h8	77h8	35H8	13	26H8	17.5	30	76

Size	AA	A	AV	AW	AX	AY	AZ	BA	BB	BC	CA	CB	CC	D	DD	DE	DF	DG	FA	FB	FC	FD	H	J	JA	JB
10	24.7	50	14	17	8	7	1	9.5	60	27	7	7	38	45h9	46h9	20H9	6	15H9	8	4	3	4.5	13	6.8	11	6.5
20	32.4	65	17	18.5	10	8	1.2	12	76	34	8.1	10	50.4	60h9	61h9	28H9	9	17H9	10	6	2.5	6.5	17	8.6	14	8.5
30	34.7	70	17	18.5	10	8	1.2	12	84	37	10.5	10.5	53.5	65h9	67h9	32H9	12	22H9	10	4.5	3	6.5	17	8.6	14	8.5
50	39.7	80	19	21	12	10	1.6	15.5	100	50	12.4	12.5	60.6	75h9	77h9	35H9	13	26H9	12	5	3	7.5	20	10.5	18	10.5

Size	JC	JD	JJ	JK	JU	JV	Q	S	SC	SD	SU	UU	WA	WB	WC	WD	WE	WF	XA	XB	XC	YA	YB	YC
10	M8 x 1.25	12	M5 x 0.8	7	M4 x 0.5	M10 x 1	34	132.5	46	50	27.3	47	15	3H9	3.5	M5 x 0.8	8	32	27	3H9	3.5	19	3H9	3.5
20	M10 x 1.5	15	M6 x 1	8	M5 x 0.5	M12 x 1.25	37	168.5	58.5	63.5	39	54	20.5	4H9	4.5	M6 x 1	10	43	36	4H9	4.5	24	4H9	4.5
30	M10 x 1.5	15	M6 x 1	8	M5 x 0.5	M12 x 1.25	40	184	63.5	69	36.4	57	23	4H9	4.5	M6 x 1	10	48	39	4H9	4.5	28	4H9	4.5
50	M12 x 1.75	18	M8 x 1.25	8	M6 x 0.75	M14 x 1.5	46	214.5	76	78	42.4	66	26.5	5H9	5.5	M8 x 1.25	12	55	45	5H9	5.5	33	5H9	5.5

## Proper Auto Switch Mounting Position

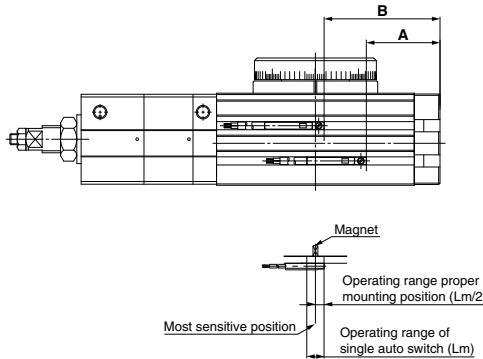

Size	Rotation	Solid state auto switch				Reed auto switch			
		D-M9□ (V), D-M9□W (V)				D-A9□, D-A9□V			
		A	B	Operating angle $\theta_m$	Hysteresis angle	A	B	Operating angle $\theta_m$	Hysteresis angle
10	190°	31	49	37°	5° or less	27	45	53°	10° or less
20	190°	39	66	33°	5° or less	35	62	50°	10° or less
30	190°	43	72	29°	5° or less	39	68	43°	10° or less
50	190°	53	87	22°	5° or less	49	83	33°	10° or less

Operating angle  $\theta_m$ : Value of the operating range  $L_m$  of a single auto switch converted to an axial rotation angle.

Hysteresis angle: Value of auto switch hysteresis converted to an angle.

Note) Since the above values are only provided as a guideline, they are not guaranteed.

In the actual setting, adjust them after confirming the auto switch operating condition.

## Detection of the Center Position

The appropriate mounting position of the center position detection auto switch is between dimensions A and B, as shown above. However, since the auto switch turns on in the range of the operating angle ( $\theta_m$ ), when one auto switch is used for detecting the center position, the auto switch turns on long before reaching the center position, as shown in the left figure below.

To avoid this, use two auto switches (as shown in the right figure below) so that the rotation may be detected from both the clockwise rotation end to the center position and from the counterclockwise rotation end to the center position.

### Center position detecting auto switch: 1 pc.      Center position detecting auto switch: 2 pcs.

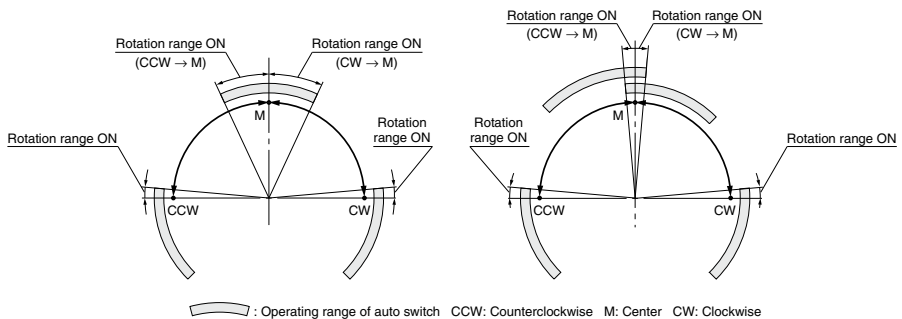



# MSZ Series

## Specific Product Precautions

Be sure to read this before handling the products.

For safety instructions as well as rotary actuator and auto switch precautions, refer to the "Handling Precautions for SMC Products" and the "Operation Manual" of each product on the SMC website: <https://www.smcworld.com>

### Operation which requires no stop at the center position

#### ⚠ Caution

1. End-to-end operation without stopping at the center position includes situations such as decelerating or pausing around the center position. Avoid use for applications in which speed change is a problem during end-to-end operation since the product may stop for max. 0.1s during high-speed rotation ( $0.2s/90^\circ$ ) and for max. 0.5s during low-speed rotation ( $1s/90^\circ$ ).

### Breathing hole

#### ⚠ Caution

1. The breathing holes located at the intermediate stopping position repeatedly absorb and release air. Care should be taken not to block the holes when mounting the product.

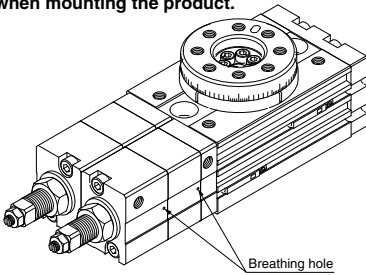

### Mounting

#### ⚠ Caution

1. Although any mounting direction is available with this product, when the gravity acting on the load acts in the direction of table rotation (e.g. the center of load gravity and the rotation center are not aligned when the rotation shaft is horizontal), stable rotation speed cannot be obtained.

In particular, since a meter-in speed controller controls the operation of rotating from the end to center position, when this operating direction is the same as the direction the gravity acts on, then gravitational acceleration cannot be controlled, which may cause bouncing when it stops.

### Backlash in the table at the center position

#### ⚠ Caution

1. Backlash in the table in the rotating direction can be controlled by adjusting the center position properly. However, backlash (about  $0.1^\circ$ ) may occur as the rotation speed increases. If this causes any problems during operation, readjust the center position.

### Behavior in the power-off condition

#### ⚠ Caution

1. When a pressure-center (PAB) type 3-position solenoid valve is used, the table as well as the solenoid valve return to the center position when the power is cut due to blackouts, etc.

If the return position must be at a particular rotation end either counterclockwise or clockwise when a blackout occurs, use two 3-port solenoid valves as shown below. Please refer to the table below for the solenoid valve type to be used.

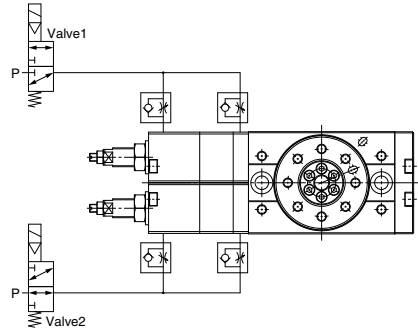

Reset potion	Valve1	Valve2
Counterclockwise rotation end	Normally closed	Normally open
Clockwise rotation end	Normally open	Normally closed

When the stop position must be held when the power is cut, use two 5-port double solenoid valves as shown below. (Plug the port A or B, that is not being used.)

