



ORIGINAL INSTRUCTIONS

Instruction Manual

3 Port Solenoid Pilot Operated Poppet Type Valve

Series VG342

The intended use of this valve is to control the movement of an actuator.

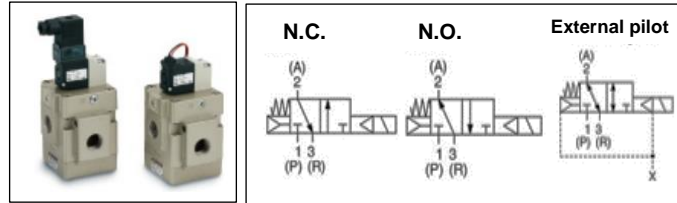

1 Safety Instructions

These safety instructions are intended to prevent hazardous situations and/or equipment damage. These instructions indicate the level of potential hazard with the labels of "Caution," "Warning" or "Danger." They are all important notes for safety and must be followed in addition to International Standards (ISO/IEC<sup>(\*)</sup>), and other safety regulations.  
<sup>(\*)</sup> ISO 4414: Pneumatic fluid power - General rules relating to systems.  
 ISO 4413: Hydraulic fluid power - General rules relating to systems.  
 IEC 60204-1: Safety of machinery - Electrical equipment of machines. (Part 1: General requirements)  
 ISO 10218-1: Robots and robotic devices - Safety requirements for industrial robots - Part 1: Robots.

- Refer to product catalogue, Operation Manual and Handling Precautions for SMC Products for additional information.
- Keep this manual in a safe place for future reference.

	<b>Caution</b>	Caution indicates a hazard with a low level of risk which, if not avoided, could result in minor or moderate injury.
	<b>Warning</b>	Warning indicates a hazard with a medium level of risk which, if not avoided, could result in death or serious injury.
	<b>Danger</b>	Danger indicates a hazard with a high level of risk which, if not avoided, will result in death or serious injury.

**Warning**

- Always ensure compliance with relevant safety laws and standards.
- All work must be carried out in a safe manner by a qualified person in compliance with applicable national regulations.
- If this equipment is used in a manner not specified by the manufacturer, the protection provided by the equipment may be impaired.

**Caution**

- The product is provided for use in manufacturing industries only. Do not use in residential premises.

2 Specifications

2.1 Valve specifications

Fluid	Air	
Operating pressure range [MPa]	Internal pilot type	0.2 to 0.9
	External pilot type	-101.2 kPa to 0.9
External pilot pressure [MPa]	Operating pressure	0.2
	Operating pressure	Equivalent operating pressure
Ambient and fluid temperature [°C]	-10 to 50 (no freezing)	
Flow characteristics	Refer to catalogue	
Response time [ms] <sup>Note 1)</sup>	30 or less (at 0.5 MPa)	
Duty cycle	Contact SMC	
Minimum operating frequency	1 cycle / 30 days	
Maximum operating frequency [Hz]	5	
Manual override	Non-locking push type	
Impact / vibration resistance [m/s <sup>2</sup> ] <sup>Note 2)</sup>	150 / 50	

2 Specifications - continued

Lubrication	Not required
Enclosure	IP50 equivalent (based on IEC60529)
Mounting orientation	Unrestricted
Weight [kg]	1.0

Table 1.

Note 1) Based on dynamic performance test, JIS B 8419: 2010. (Coil temperature: 20°C, at rated voltage, without surge suppressor).  
 Note 2) **Impact resistance:** No malfunction occurred when it is tested with a drop tester in the axial direction and at the right angles to the main valve and armature in both energized and de-energized states every once for each condition. (Values quoted are for a new valve).  
**Vibration resistance:** No malfunction occurred in a one-sweep test between 45 and 1000 Hz. Test was performed at both energized states in the axial direction and at the right angles to the main valve and armature. (Values quoted are for a new valve).

2.2 Solenoid specifications

Pilot valve	VO307#-###1-X84(-Q)		
Rated coil voltage [V]	AC (50 / 60 Hz)	100, 200, 110, 220, 240	
	DC	12, 24	
Electrical entry	Grommet (G), DIN terminal (D)		
Lead wire colour	100 VAC	Blue	
	200 VAC	Red	
	24 VDC	Red / black	
Allowable voltage fluctuation <sup>Note 1)</sup>	-15 to 10% of rated voltage		
Apparent power [VA]	AC	Inrush 50 Hz	12.7
		60 Hz	10.7
	Holding	50 Hz	7.6
		60 Hz	5.4
Power consumption [W]	DC	Without indicator light: 4 With indicator light: 4.2	
Surge voltage suppressor	AC	Varistor	
Indicator light	DC	Diode	
		LED	

Table 2.

Note 1) Valve state is not defined if electrical input is outside of specified operating ranges.

2.3 Energy saving type: VG342#-###-###-Y(-Q)

- Use energy-saving type if low power consumption is required for

Power consumption [W]	DC	Without indicator light: 1.8
		With indicator light: 2

Table 3.

2.4 Continuous duty type VG342#-###-###-E(-Q)

- If the valve is to be energized for long periods of time, use continuous duty type.
- Specifications different from standard are as follows:

Apparent power [VA]	AC	Inrush 50 Hz	7.9
		60 Hz	6.2
	Holding	50 Hz	5.8
		60 Hz	3.5
Power consumption [W]	DC	Without indicator light: 1.8 With indicator light: 2	

Table 4.

**Caution**

- This model is for continuous duty, not for high cycle rates. But even in low cycle rates, if the valve is energized more than once a day, life may be reduced.

2.5 Indicator light

Only available for valves with DIN connector.

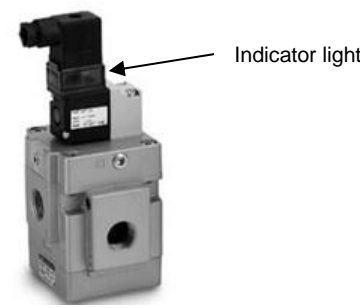

Figure 1.

2 Specifications - continued

2.6 Special products

**Warning**

Special products (-X) might have specifications different from those shown in this section. Contact SMC for specific drawings.

3 Installation

3.1 Installation

**Warning**

- Do not install the product unless the safety instructions have been read and understood.

3.2 Environment

**Warning**

- Do not use in an environment where corrosive gases, chemicals, salt water or steam are present.
- Do not use in an explosive atmosphere.
- Do not expose to direct sunlight. Use a suitable protective cover.
- Do not install in a location subject to vibration or impact in excess of the product's specifications.
- Do not mount in a location exposed to radiant heat that would result in temperatures in excess of the product's specifications.
- When the solenoid valve is mounted in a control panel or it is energized for a long time, make sure that the ambient temperature is within the specification of the valve.
- If using in an atmosphere where there is possible contact with water droplets, oil, weld spatter, etc., take suitable preventive measures.
- Do not use in high humidity environment where condensation can occur.
- Contact SMC for altitude limitations.

3.3 Piping

**Caution**

- Before connecting piping make sure to clean up chips, cutting oil, dust etc.
- When installing piping or fittings, ensure sealant material does not enter inside the port. When using seal tape, leave 1 thread exposed on the end of the pipe/fitting.

- Since PE port is the exhaust port of the pilot valve, do not attach a plug or reduce the port diameter.
- X port is the pressure supply port of the pilot valve and PE port is the exhaust port of the pilot valve. Avoid mismatching when piping.

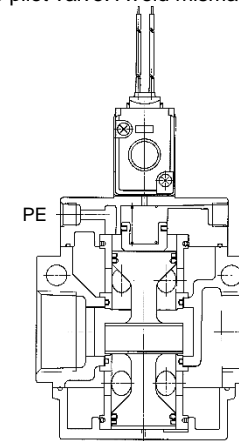

Figure 2.

- Tighten fittings to the specified tightening torque.

Port	Connection thread size (R, NPT)	Tightening Torque [N·m]
X (External pilot), PE	1/8	3 to 5
	1/2	20 to 25
1(P), 2(A), 3(R)	3/4	28 to 30
	1	36 to 38

Table 5.

3.4 Lubrication

**Caution**

- SMC products have been lubricated for life at manufacture, and do not require lubrication in service.
- If a lubricant is used in the system, refer to catalogue for details.

3 Installation - continued

3.5 Air supply

**Warning**

- Use clean air. If the compressed air supply includes chemicals, synthetic materials (including organic solvents), salinity, corrosive gas etc., it can lead to damage or malfunction.

**Caution**

- Install an air filter upstream of the valve. Select an air filter with a filtration size of 5µm or smaller.

3.6 Light/surge voltage suppressor

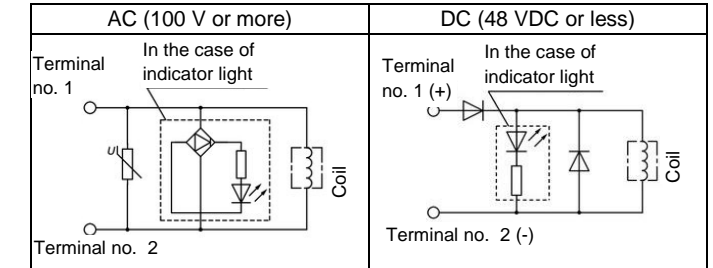

Figure 3.

**Caution**

In the case of valves without surge suppressor, the machine designer shall add suppression as close as possible to the valve.

3.7 How to use DIN terminal

Refer to catalogue for details.

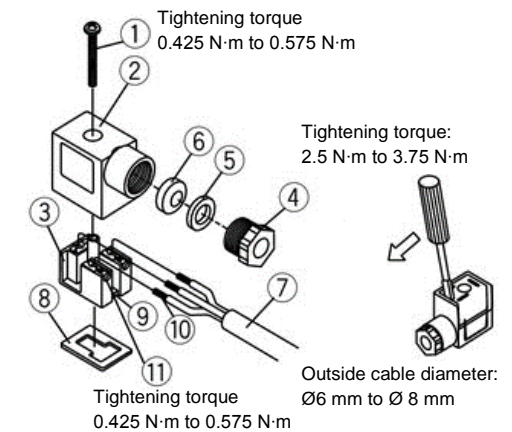

Figure 4.

Note: Connector orientation can be changed by 180 degrees depending how to assemble the housing (2) and the terminal block (3).

3.8 Electrical connection

In the case of DIN terminal (with light/surge voltage suppressor), the connection is as follows. Connect each to the power supply side.

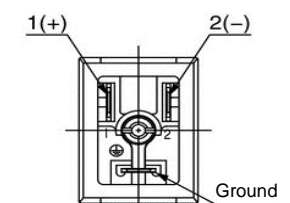

Figure 5.

### 3 Installation - continued

#### 3.9 Residual voltage

##### Caution

- If a Zener diode or varistor voltage suppressor is used, the suppressor arrests the back EMF voltage from the coil to a level in proportion to the rated voltage.
- Ensure the transient voltage is within the specification of the host controller.
- Contact SMC for the Zener diode or varistor residual voltage.
- In the case of a diode, the residual voltage is approximately 1 V.
- Valve response time is dependent on surge suppression method selected.

#### 3.10 Countermeasure for surge voltage

##### Caution

- At times of sudden interruption of the power supply, the energy stored in a large inductive device may cause non-polar type valves in a de-energised state to switch.
- When installing a breaker circuit to isolate the power, consider a valve with polarity (with polarity protection diode), or install a surge absorption diode across the output of the breaker.

#### 3.11 Extended periods of continuous energization

##### Warning

If a standard or energy-saving type valve is energized continuously for a long period of time or is mounted in a control panel, the rise in temperature due to heat rise of the coil assembly may cause a decline in solenoid valve performance, reduce service life, or have adverse effects on peripheral equipment. If the valve is energized continuously for a long period of time, be sure to use the continuous duty type VG342#-###-###-E(-Q) and make sure to radiate heat sufficiently.

#### 3.12 Manual override

##### Warning

Regardless of an electric signal for the valve, the manual override is used for switching the main valve. Since connected equipment will operate when the manual override is activated, confirm that conditions are safe prior to activation.

### 4 Settings

#### 4.1 Changing valve function (N.C./N.O./external pilot)

##### 4.1.1 Change function plate

##### Caution

- When changing the passage state, confirm that pressure has been removed from the valve.
- Unscrew the M4 x 0.7 hexagon socket head cap screw in the changeover plate and match the ◀mark on the adapter plate with the character on the changeover plate.
- Tighten the M4 mounting screws to the recommended tightening torque of 1.4 N·m.

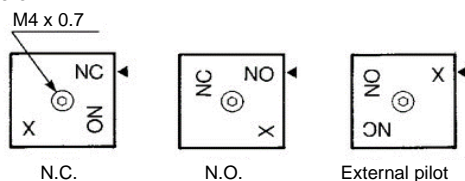

Figure 6.

##### 4.1.2 Porting

Port Passage	P	A	R
N.C.	Inlet	Outlet	Exhaust side (Plug, in case of 2 port valve)
N.O.	Exhaust side (Plug, in case of 2 port valve)	Outlet	Inlet
External pilot	Universal porting (Piping of inlet pressure side is possible anywhere)		

Table 6.

### 5 How to Order

Refer to catalogue for 'How to order' or product drawing for special products.

### 6 Outline Dimensions (mm)

Refer to catalogue for outline dimensions.

### 7 Maintenance

#### 7.1 General maintenance

##### Caution

- Not following proper maintenance procedures could cause the product to malfunction and lead to equipment damage.
- If handled improperly, compressed air can be dangerous.
- Maintenance of pneumatic systems should be performed only by qualified personnel.
- Before performing maintenance, turn off the power supply and be sure to cut off the supply pressure. Confirm that the air is released to atmosphere.
- After installation and maintenance, apply operating pressure and power to the equipment and perform appropriate functional and leakage tests to make sure the equipment is installed correctly.
- If any electrical connections are disturbed during maintenance, ensure they are reconnected correctly and safety checks are carried out as required to ensure continued compliance with applicable national regulations.
- Do not make any modification to the product.
- Do not disassemble the product, unless required by installation or maintenance instructions.

#### 7.2 Pilot valve assembly / DIN connector replacement

##### Caution

- Ensure gaskets are in good condition, not deformed and are dust and debris free.
- When mounting pilot valves ensure gaskets are present, aligned and securely in place and tighten screws to a torque of 1.4 N·m.
- Refer to catalogue for pilot valve and DIN connector "How to order".

### 8 Limitations of Use

##### Warning

The system designer should determine the effect of the possible failure modes of the product on the system.

#### 8.1 Limited warranty and disclaimer/compliance requirements

Refer to Handling Precautions for SMC Products.

#### 8.2 Leakage voltage

##### Caution

Ensure that any leakage voltage caused by the leakage current when the switching element is OFF is  $\leq 3\%$  (for DC coils) or  $\leq 15\%$  (for AC coils) of the rated voltage across the valve.

#### 8.3 Low temperature operation

##### Caution

Unless otherwise indicated in the specifications for each valve, operation is possible to  $-10^{\circ}\text{C}$ , but appropriate measures should be taken to avoid solidification or freezing of drainage and moisture, etc.

#### 8.4 Holding of pressure (including vacuum)

##### Warning

Since valves are subject to air leakage, they cannot be used for applications such as holding pressure (including vacuum) in a system.

#### 8.5 Cannot be used as an emergency shut-off valve

##### Warning

This product is not designed for safety applications such as an emergency shut-off valve. If the valves are used in this type of system, other reliable safety assurance measures should be adopted.

#### 8.6 Air /spring returned spool valves

##### Warning

The main valve returns to the original (de-energized) position by means of the spring when the air supply is cut. When only the electricity is cut, the return is by means of the pilot pressure and spring force.

### 8 Limitations of Use - continued

#### 8.7 Safety relays or PLC

##### Warning

If a safe output from a safety relay or PLC is used to operate this valve, ensure that any output test pulse duration is shorter than 1 ms to avoid the valve solenoid responding.

### 9 Product Disposal

This product shall not be disposed of as municipal waste. Check your local regulations and guidelines to dispose this product correctly, in order to reduce the impact on human health and the environment.

### 10 Contacts

Refer to [www.smcworld.com](http://www.smcworld.com) or [www.smc.eu](http://www.smc.eu) for your local distributor/importer.

## SMC Corporation

URL : <https://www.smcworld.com> (Global) <https://www.smc.eu> (Europe)  
 SMC Corporation, 4-14-1, Sotokanda, Chiyoda-ku, Tokyo 101-0021, Japan  
 Specifications are subject to change without prior notice from the manufacturer.  
 © 2021 SMC Corporation All Rights Reserved.  
 Template DKP50047-F-085M